

PARKING BRAKES

CONTENTS

E36AA--

GENERAL INFORMATION	2	SERVICE ADJUSTMENT PROCEDURES	4
SPECIFICATIONS	3	Checking of the Parking Brake Lever Lock ..	4
General Specifications	3	Inspection and Adjustment of Parking Brake	
Service Specifications	3	Lever Stroke (2WD)	4
Lubricants	3	Inspection and Adjustment of Parking Brake	
TROUBLESHOOTING	3	Lever Stroke (4WD)	5
		PARKING BRAKES (2WD)	7
		PARKING BRAKES (4WD)	13

GENERAL INFORMATION

The parking brake is the mechanical brakes acting on rear wheels. The parking lever is the lever type. Type V brake cable is used in 2WD vehicles, and Type T brake cable in 4WD vehicles.

2WD

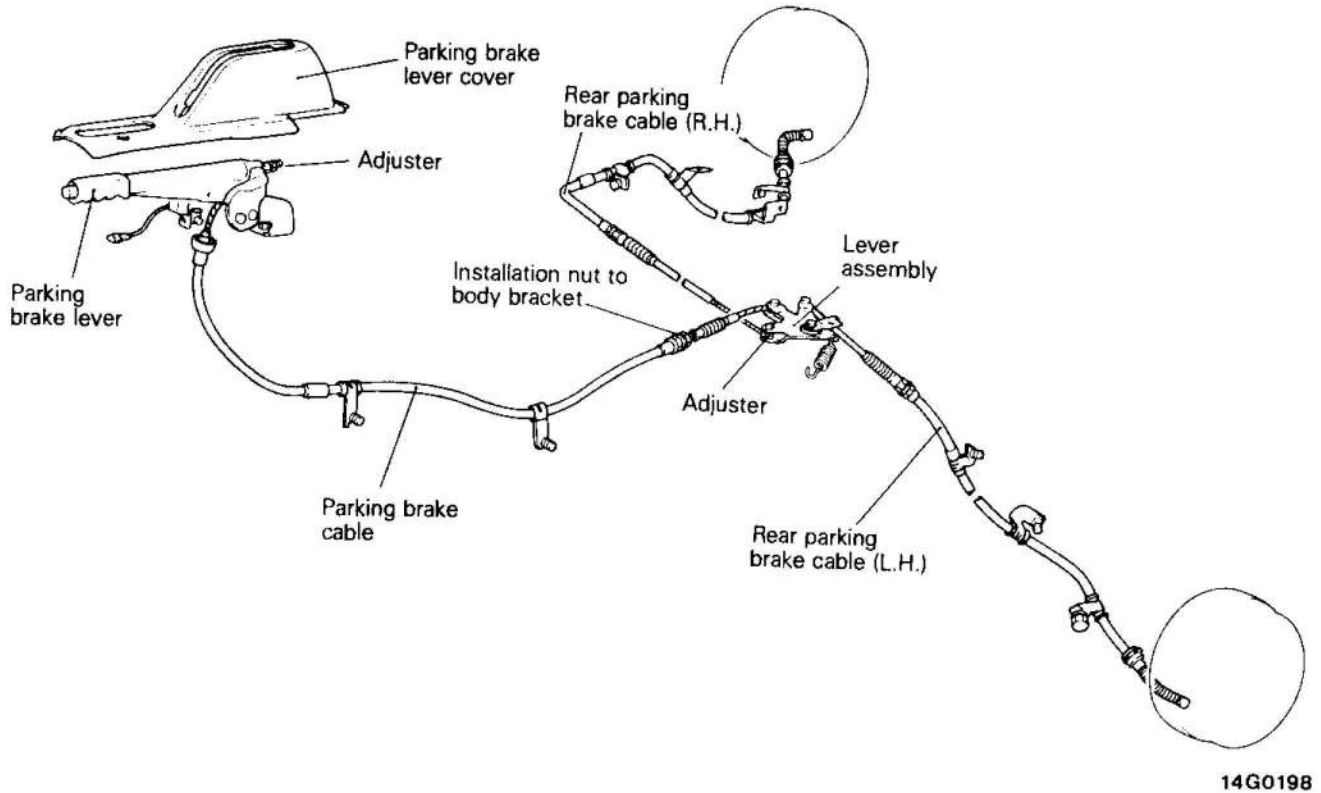

4WD

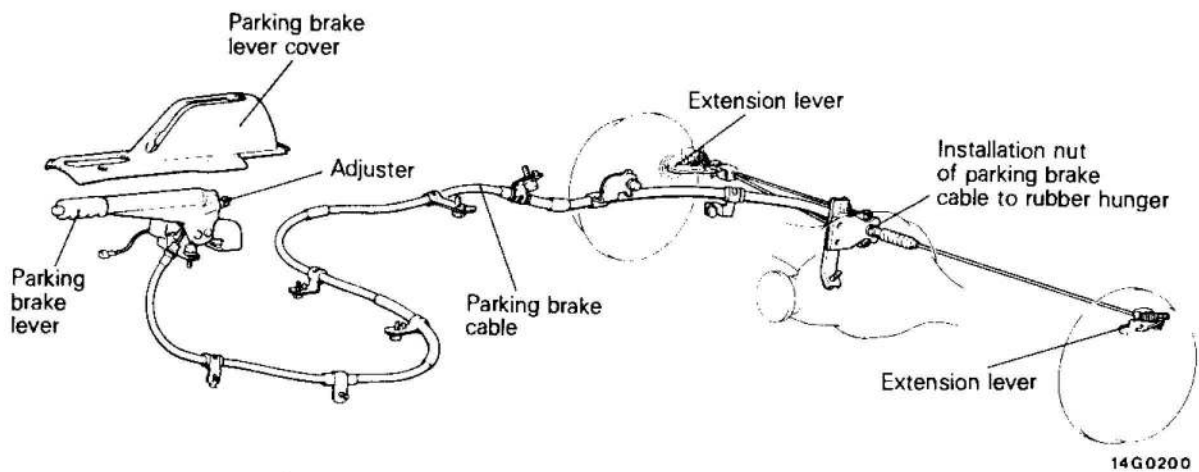

SPECIFICATIONS

EMCA--

GENERAL SPECIFICATIONS

Items	2WD	4WD
Type	Mechanical brake acting on rear wheels	Mechanical brake acting on rear wheels
Brake lever type	Lever type	Lever type
Cable arrangement	V-type	T-type

SERVICE SPECIFICATIONS

EMCB--

Items	2WD	4WD
Standard value Parking brake lever stroke	4-6 notches	5-7 notches

LUBRICANTS

EMCD--

Items	Specified lubricant	Quantity
Parking brake lever ratchet pole and ratchet plate teeth sliding part	Multipurpose grease SAE J310, NLGI No.2	As required
Lever assembly sliding part	Multipurpose grease SAE J310, NLGI No.2	As required

TROUBLESHOOTING

EMEAAB

Symptom	Probable cause	Remedy	Reference Page
Poor parking brake function	Worn brake lining	Replace	-
	Poor condition of brake lining surface	Replace	36-7, 13
	Parking brake cable sticking	Replace	-
	Auto-adjuster malfunction	Refer to GROUP 35	-
	Excessive parking brake lever stroke	Adjust the parking brake lever stroke or check the parking brake cable arrangement	36-4, 5

SERVICE ADJUSTMENT PROCEDURES

CHECKING OF THE PARKING BRAKE LEVER LOCK
(VEHICLES FOR AUSTRALIA)

E36FBAF

Push the knob at the end of the parking brake lever without raising the lever to make sure that the lever does not return.

L.H. drive vehicles

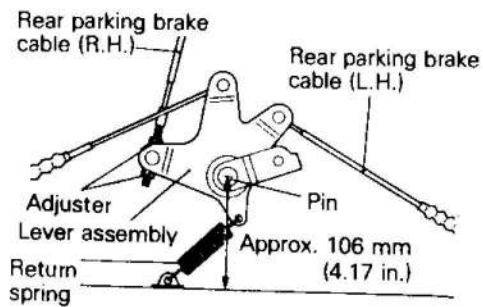

14G0188

R.H. drive vehicles

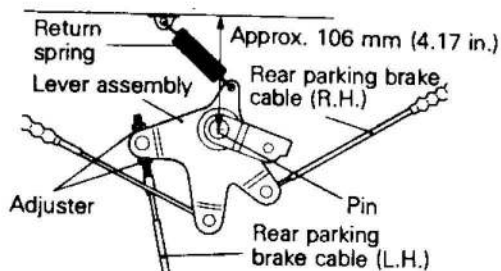

14G0058

INSPECTION AND ADJUSTMENT OF PARKING
BRAKE LEVER STROKE (2WD)

E36FAAF

1. Pull the parking brake lever at a force of 200 N (20 kg, 45 lbs.) and confirm that it is at the notch of standard value.

Standard value: 4–6 notches

2. If the displacement of the lever is outside the standard range, adjust according to the following procedure.
 - (1) Remove parking brake lever cover.
 - (2) Loosen the adjuster in the parking brake lever assembly until the parking brake cable slackens.
 - (3) For vehicles equipped with duo-servo drum brakes, pump the brake pedal while moving the vehicle backward, to adjust the rear brake shoe clearance.
 - (4) For vehicles equipped with leading trailing drum brakes, pull the parking brake lever repeatedly at a force of 200 N (20 kg, 45 lbs.) to adjust the rear brake shoe clearance.
 - (5) Release the parking brake lever and confirm the distance from the center of the lever assembly pin to the body side meets the value given in the figure. If the distance does not match the dimension in the figure due to a stretched parking brake cable or other reasons, adjust this dimension with the adjuster in the lever assembly.

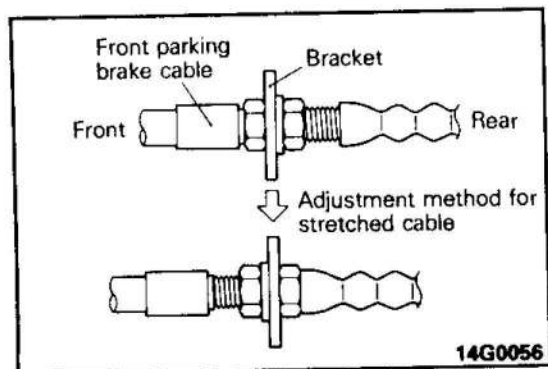
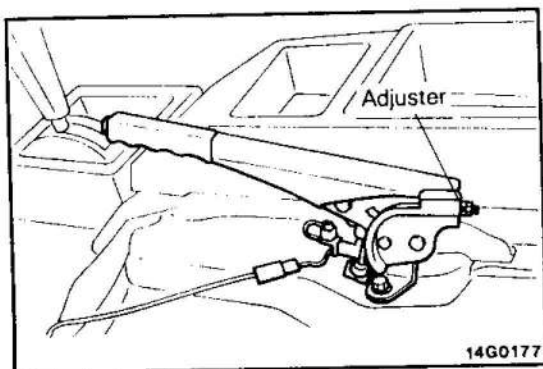

- (6) Adjust the adjuster in the parking brake lever assembly so that the lever displacement becomes the standard value when the lever is pulled with a force of 200 N (20 kg, 45 lbs.).

Standard value: 4–6 notches

- (7) After adjusting, confirm that there is no backlash between the parking brake lever and the adjuster when the parking brake lever is restored.

NOTE

When adjustment by the adjuster is not possible (no leeway for adjustment) due to a stretched parking brake inner cable, loosen the parking brake lever adjuster and adjust the stroke with the nut mounting the parking brake cable to the body bracket interchanged as shown in the figure.

3. Confirm the rear brake does not contact when the parking brake lever is restored.

INSPECTION AND ADJUSTMENT OF PARKING BRAKE LEVER STROKE (4WD)

E36FAAH

1. Pull the parking brake lever at a force of 200 N (20 kg, 45 lbs.) and confirm that it is at the notch of standard value.

Standard value: 5–7 notches

2. If the displacement of the lever is outside the standard range, adjust according to the following procedure.
 - (1) Remove parking brake lever cover.
 - (2) Loosen the adjuster in the parking brake lever assembly until the parking brake cable slackens.
 - (3) Pull and release the parking brake lever repeatedly to adjust rear brake shoe clearance.
 - (4) For vehicles equipped with leading trailing drum brakes, pull the parking brake lever repeatedly at a force of 200 N (20 kg, 45 lbs.) to adjust the rear brake shoe clearance.

Standard value: 5–7 notches

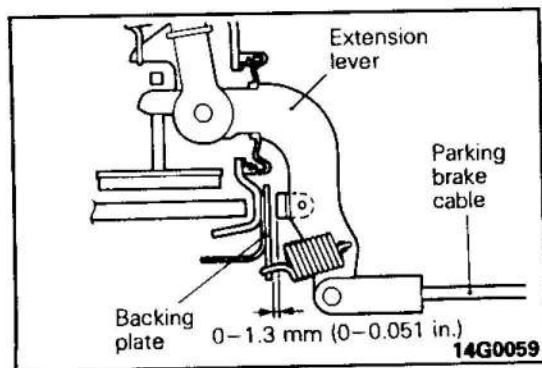

- (5) Confirm the clearance between the rear brake extension lever and the backing plate has the dimension indicated in the figure for the right and left wheel when the parking brake lever is restored.

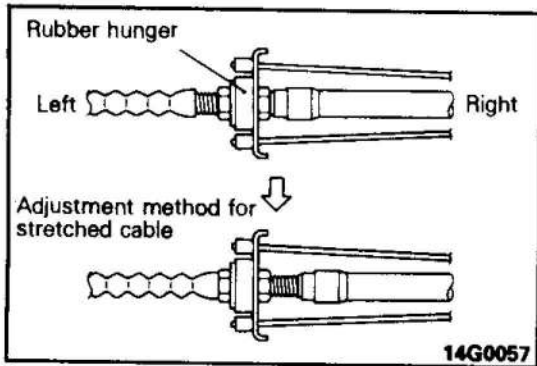
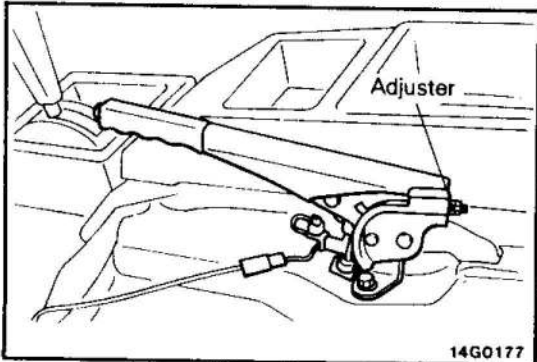
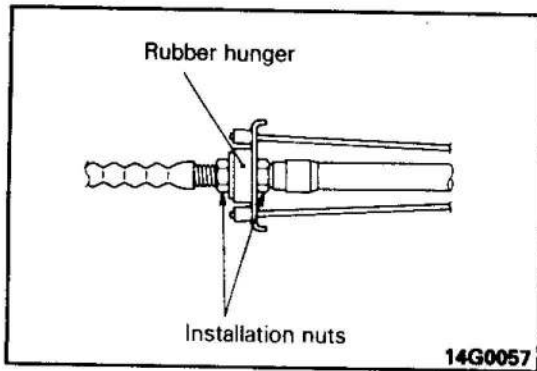

(6) If the clearance does not match the value in the figure, there is a difference in the lengths of the left and right parking brake cables. In this case, adjust clearances of both left and right wheels by the parking brake cable rubber hanger installation nut. In this adjustment, re-adjust the stroke with the adjuster in the parking brake lever assembly. Also, as improper shoe clearance may be due to a malfunctioning rear brake adjuster, adjust the shoe outside diameter (Refer to GROUP 35 SERVICE BRAKES—Rear Drum Brake Shoe.) after confirming the function of the adjuster, and re-adjust the shoe clearance.

(7) After adjusting, confirm that there is no backlash between the parking brake lever and the adjuster when the parking brake lever is restored.

NOTE

If, due to a stretched parking brake inner cable, it is not possible to make correct adjustment with the adjuster in the parking brake lever assembly (with no leeway for adjustment), loosen the adjuster and adjust so that the parking brake cable outer cable is extended (while keeping the clearance between the extension lever and backing plate within the specified range). Adjust the stroke.

3. Confirm the rear brake does not contact when the parking brake lever is restored.

PARKING BRAKES (2WD)

REMOVAL AND INSTALLATION

L.H. drive vehicles

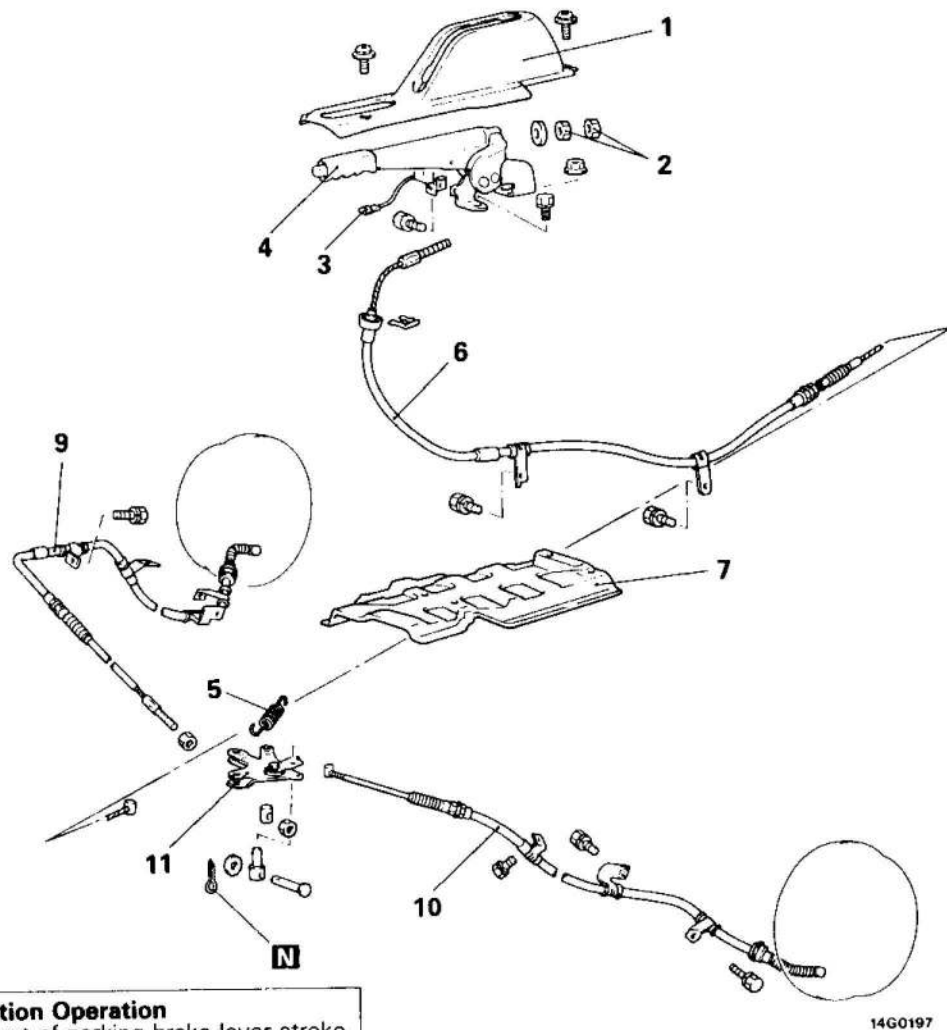

Post-installation Operation

- Adjustment of parking brake lever stroke (Refer to P. 36-4.)

Removal steps

- ◆◆ 1. Parking Brake Lever Cover
 - ◆◆ Confirmation of the parking brake cable boot fixing position
 - ◆◆ Confirmation placement of parking brake cables
 - ◆◆ Adjustment of rear parking brake cable mounting position
- ◆◆ 2. Adjuster
- ◆◆ 3. Connection of parking brake switch
- ◆◆◆◆ 4. Parking brake lever
- ◆◆ 5. Return spring
- ◆◆ 6. Front parking brake cable
- ◆◆ 7. Heat protector
- ◆◆ 8. Fuel tank
- ◆◆◆◆ 9. Rear parking brake cable (R.H.)
- ◆◆◆◆ 10. Rear parking brake cable (L.H.)
- ◆◆ 11. Lever assembly

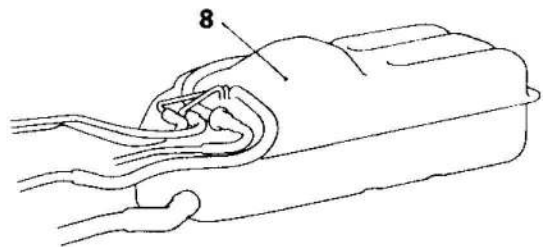

NOTE

- (1) Reverse the removal procedures to reinstall.
- (2) ◆◆ : Refer to "Service Points of Removal".
- (3) ◆◆◆◆ : Refer to "Service Points of Installation".
- (4) **N** : Non-reusable parts

R.H. drive vehicles

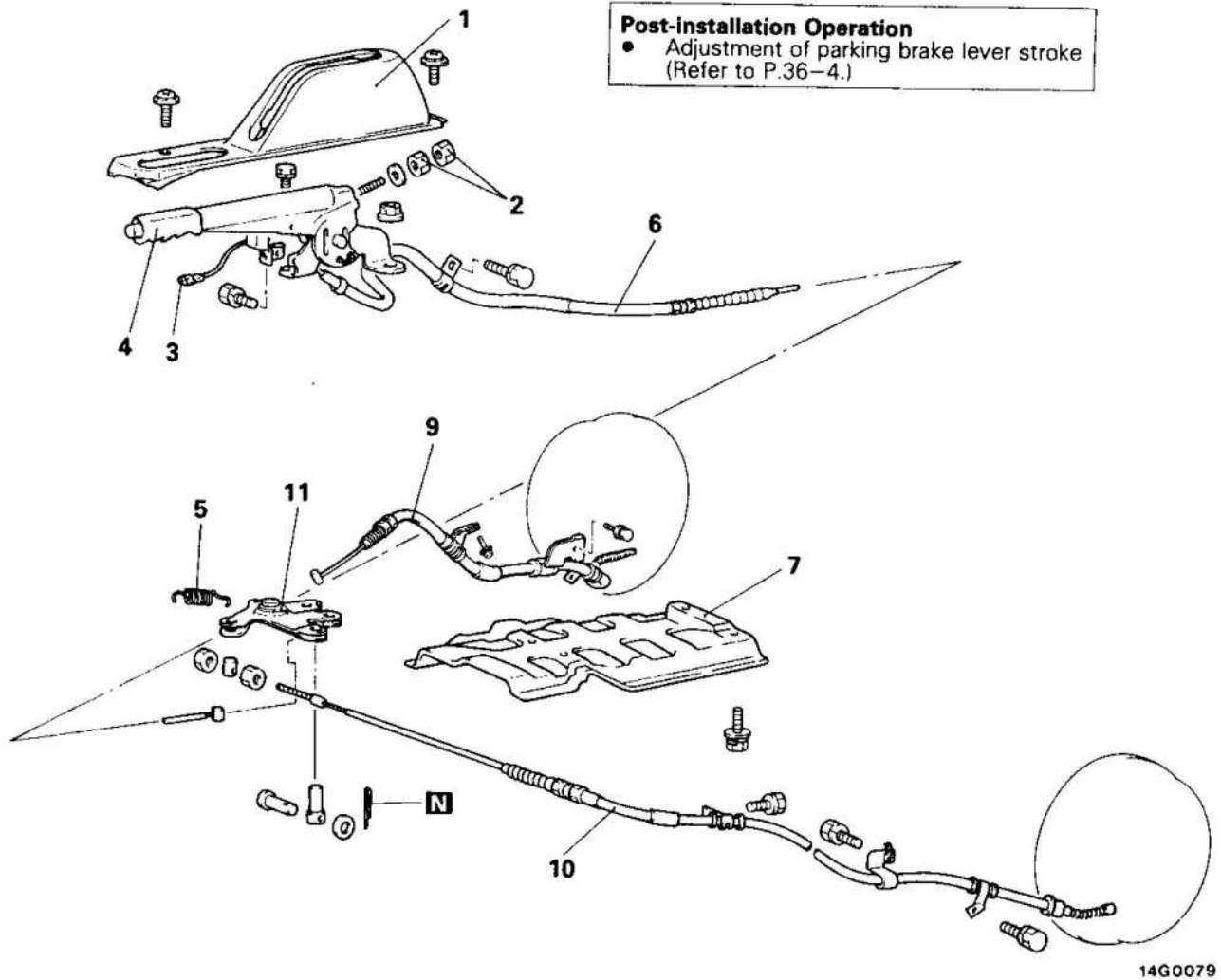

Post-installation Operation
 • Adjustment of parking brake lever stroke (Refer to P.36-4.)

Removal steps

1. Parking Brake Lever Cover
 - ◆◆ Confirmation of the parking brake cable boot fixing position
 - ◆◆ Confirmation placement of parking brake cables
 - ◆◆ Adjustment of rear parking brake cable mounting position
2. Adjuster
3. Connection of parking brake switch
- ◆◆◆◆ 4. Parking brake lever
- ◆◆◆◆ 5. Return spring
- ◆◆◆◆ 6. Front parking brake cable
- ◆◆◆◆ 7. Heat protector
- ◆◆◆◆ 8. Fuel tank
- ◆◆◆◆◆◆ 9. Rear parking brake cable (R.H.)
- ◆◆◆◆◆◆ 10. Rear parking brake cable (L.H.)
- ◆◆◆◆◆◆ 11. Lever assembly

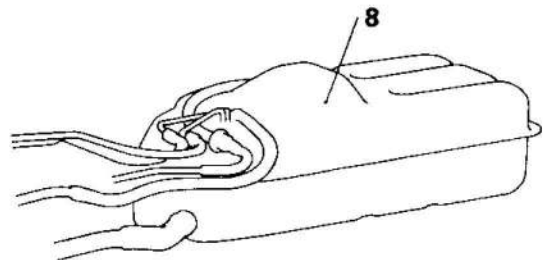

NOTE
 (1) Reverse the removal procedures to reinstall.
 (2) ◆◆ : Refer to "Service Points of Removal".
 (3) ◆◆◆ : Refer to "Service Points of Installation".
 (4) **N** : Non-reusable parts

E36GBAE

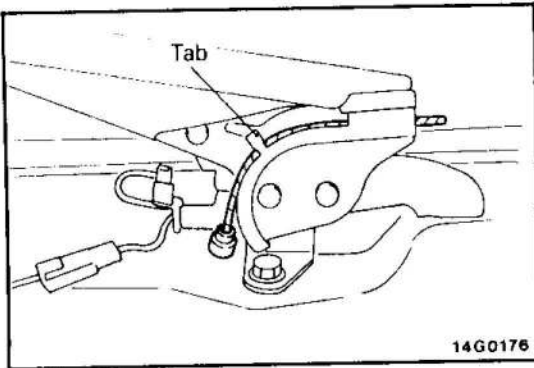

SERVICE POINTS OF REMOVAL

4. REMOVAL OF PARKING BRAKE LEVER

Release the latch holding the cable to the parking brake lever and remove the parking brake lever.

7. REMOVAL OF HEAT PROTECTOR

Remove the heat protector attaching bolt, and move the heat protector to the rear of the vehicle.

8. REMOVAL OF FUEL TANK

Disconnect the following hoses by referring to GROUP 13 FUEL SYSTEM—Fuel Tank.

- (1) Disconnect the fuel gauge unit, fuel main hose, fuel return hose and fuel vapor hose.
- (2) Loosen the fuel filler hose bracket mounting bolt.
- (3) Raise fuel tank with a transmission jack and remove fuel tank mounting nuts.
Lower fuel tank 300 mm (12 in.).
Refer to GROUP 13 FUEL—Fuel Tank.

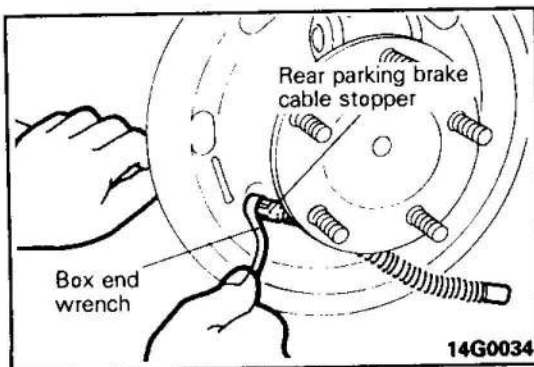

9. REMOVAL OF REAR PARKING CABLE (R.H.)/10. REAR PARKING BRAKE CABLE (L.H.)

- (1) Remove rear parking brake cable clamps.
- (2) Remove brake drum and brake shoe.
- (3) Remove rear parking brake cable end from the brake shoe.
- (4) Pass the rear parking brake cable through a box end wrench (12 mm, 15/32 in.), and press the cable in until the rear parking brake cable stopper latch is compressed.
- (5) Pull the rear parking brake cable through to the rear side of the backing plate.

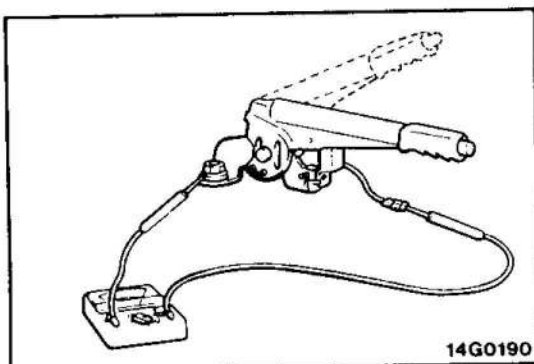

INSPECTION

E36GCAC

- Abrasion on the parking brake lever latch.
- Defective or malfunctioning parking brake cable.

PARKING BRAKE SWITCH OPERATION CHECK

Disconnect the parking brake switch and connect circuit tester as shown in the figure.

The parking brake switch is correct if circuit continuity exists with the parking brake lever pulled, and no continuity when the parking brake lever is restored.

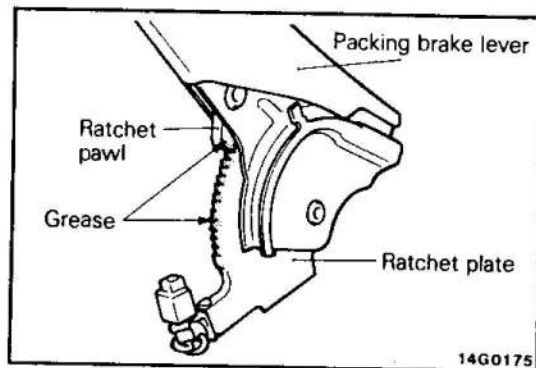
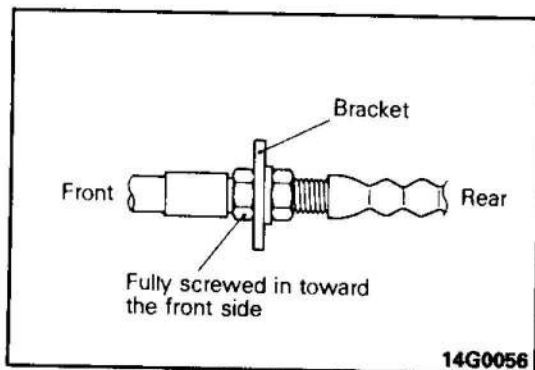
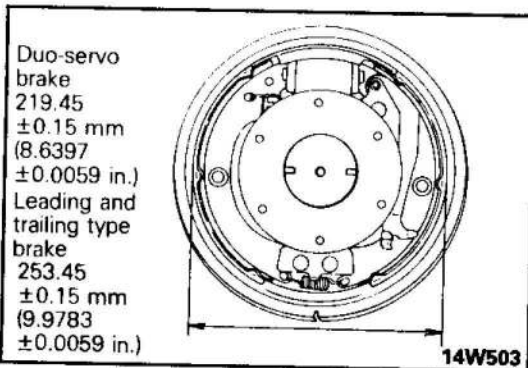
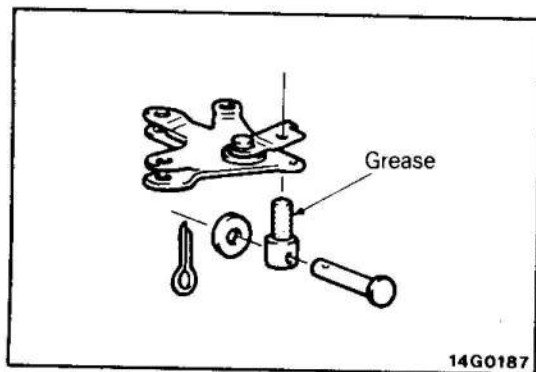

SERVICE POINTS OF INSTALLATION

11. APPLICATION OF GREASE TO LEVER ASSEMBLY

Apply specified grease to the sliding part of the lever assembly.

Specified grease: Multipurpose grease SAE J310, NLGI No.2

10. INSTALLATION OF REAR PARKING BRAKE CABLE (L.H.)/9. REAR PARKING BRAKE CABLE (R.H.)

- (1) Connect the rear parking brake cable to the rear brake, and rotate adjuster until the brake shoe outside diameter has the dimension given in the figure.
- (2) Determine the positions of the rear parking brake cable clamps and fit the nails into body holes and fix.

6. INSTALLATION OF FRONT PARKING BRAKE CABLE

- (1) Fit the positioning nails of the front parking brake cable clamps into the body holes and fix.
- (2) Install front parking brake cable so that it is the shortest (mounting nut at bracket is the position as shown in figure).

4. APPLICATION OF GREASE TO PARKING BRAKE LEVER

Apply specified grease to the sliding part between the parking brake lever ratchet pawl and ratchet plate teeth.

Specified grease: Multipurpose grease SAE J310, NLGI No.2

L.H. drive vehicles

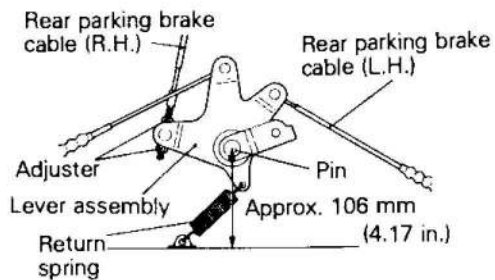

14G0188

R.H. drive vehicles

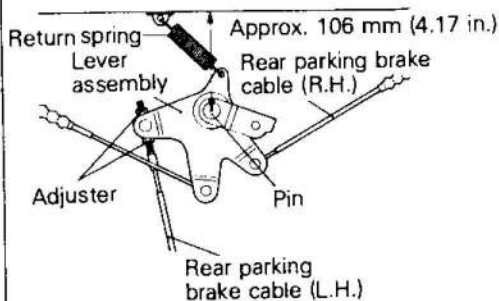

14G0058

• **ADJUSTMENT OF REAR PARKING BRAKE CABLE MOUNTING POSITION**

L.H. drive vehicles

Adjust the rear parking brake cable adjuster (R.H.) so that the distance between the center of the lever assembly pin to the body face has the dimension given in the figure with the parking brake lever restored.

R.H. drive vehicles

Adjust the rear parking brake cable adjuster (L.H.) so that the distance between the center of the lever assembly pin to the body face has the dimension given in the figure with the parking brake lever restored.

• **CONFIRMATION OF PLACEMENT OF PARKING BRAKE CABLES**

- (1) Remove brake drum.
- (2) Confirm the lever touches the brake shoe with the parking brake lever assembly restored.
- (3) If the lever does not touch the brake shoe, the cable clamp positions are displaced or the cable has tension. Take appropriate countermeasures.
- (4) Remount brake drum.

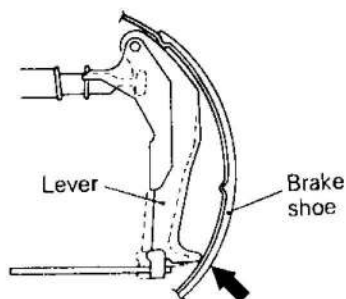

14W509

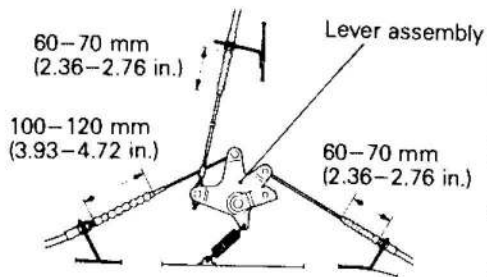
L.H. drive vehicles

14G0189

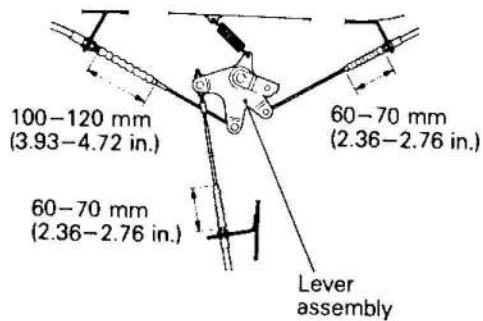
R.H. drive vehicles

14G0060

- **CONFIRMATION OF THE PARKING BRAKE CABLE BOOT FIXING POSITION**

Confirm parking brake boot has the dimension given in the figure with the parking brake lever assembly restored.

NOTE

1. If the boot attaching dimension is too long, the boot may come out of the parking brake cable outer cable as the brake is used, allowing moisture to enter the cable and cable to subsequently stick.
2. When the boot length is not as indicated in the figure, adjust the length by moving the caulking at the boot tip.

PARKING BRAKES (4WD)

REMOVAL AND INSTALLATION

L.H. drive vehicles

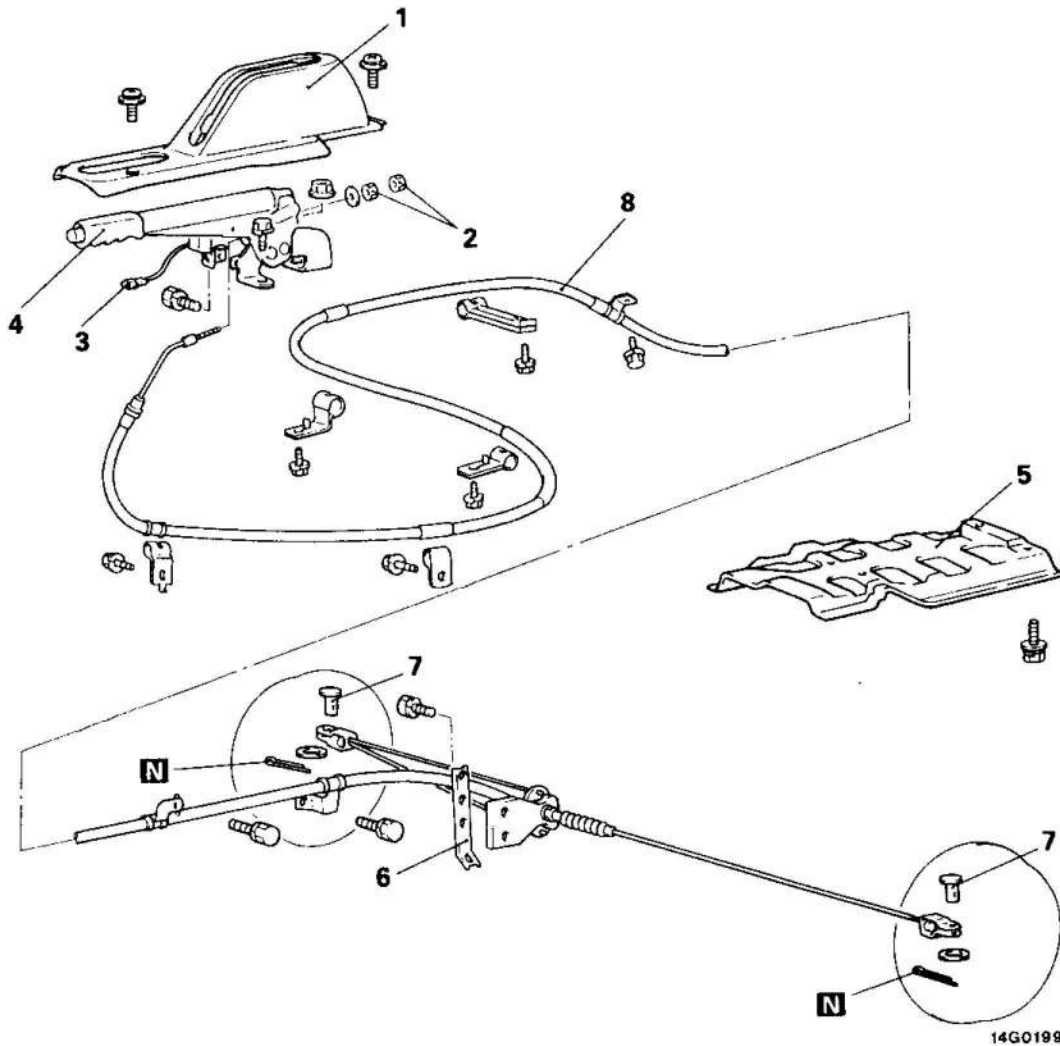

Post-installation Operation

- Adjustment of parking brake lever stroke (Refer to P.36-5.)

Removal steps

1. Parking brake lever cover
- ◆◆ Confirmation of the parking brake cable boot fixing position
2. Adjuster
3. Connection of parking brake switch
- ◆◆ ◆◆ 4. Parking brake lever
- ◆◆ 5. Heat protector
6. Plate
7. Clevis pin
- ◆◆ ◆◆ 8. Parking brake cable

NOTE

- (1) Reverse the removal procedures to reinstall.
- (2) ◆◆ : Refer to "Service Points of Removal".
- (3) ◆◆◆ : Refer to "Service Points of Installation".
- (4) **N** : Non-reusable parts

R.H. drive vehicles

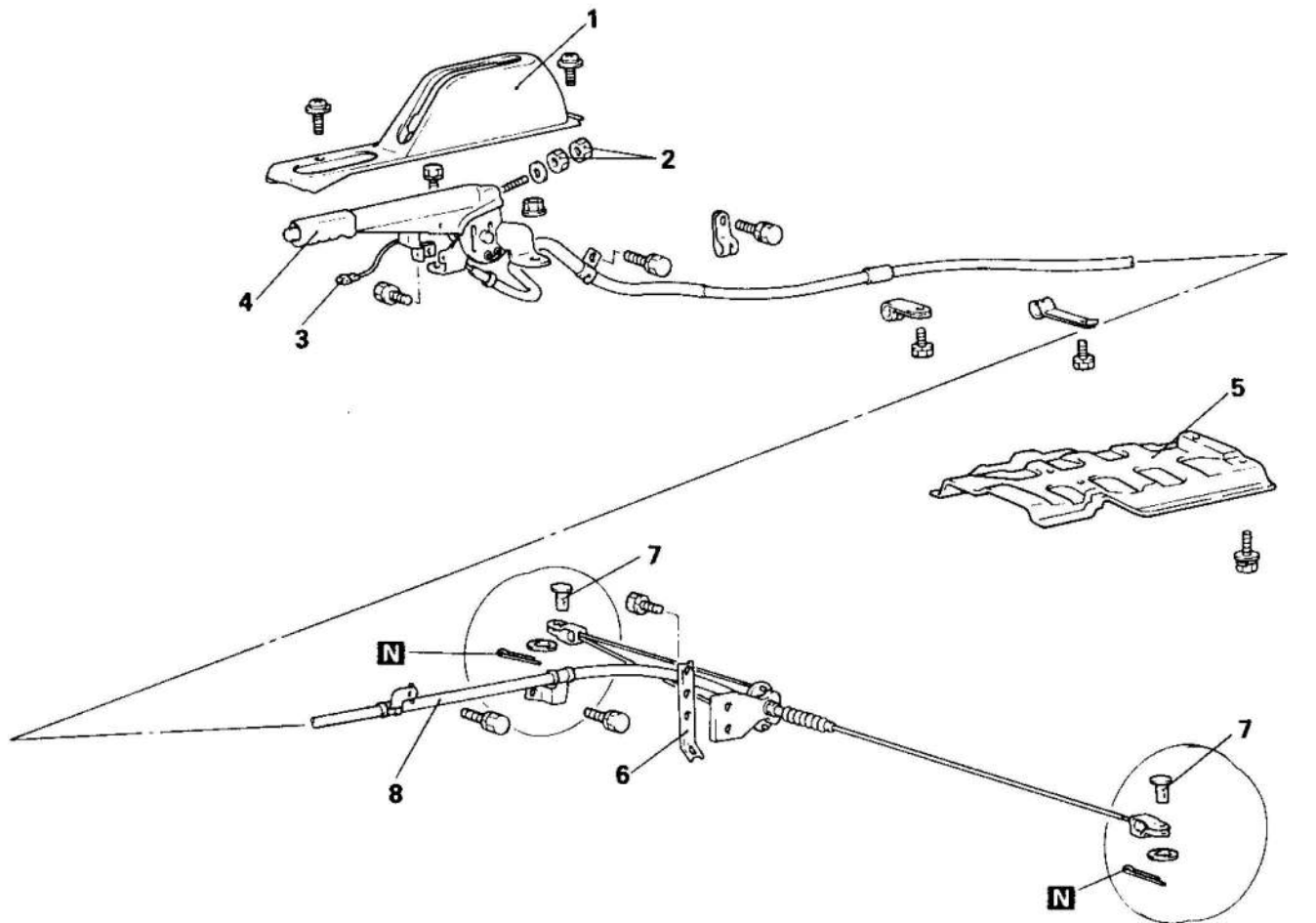

14G0078

Post-installation Operation

- Adjustment of parking brake lever stroke (Refer to P.36-5.)

Removal steps

1. Parking brake lever cover
- ◆◆ Confirmation of the parking brake cable boot fixing position
2. Adjuster
3. Connection of parking brake switch
- ◆◆◆◆ 4. Parking brake lever
- ◆◆ 5. Heat protector
6. Plate
7. Clevis pin
- ◆◆ 8. Parking brake cable

NOTE

- (1) Reverse the removal procedures to reinstall.
- (2) ◆◆ : Refer to "Service Points of Removal".
- (3) ◆◆◆ : Refer to "Service Points of Installation".
- (4) **N** : Non-reusable parts

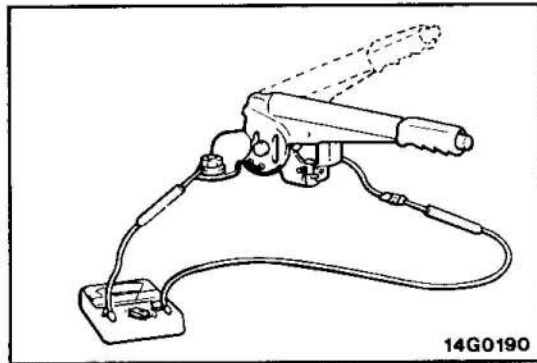
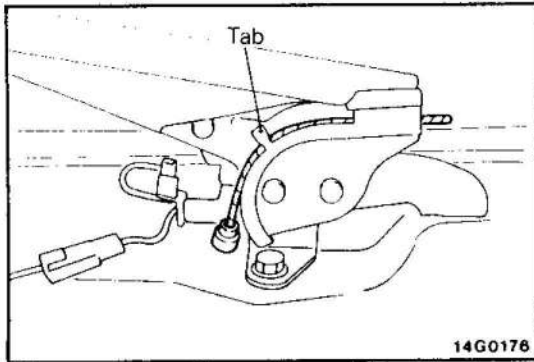

SERVICE POINTS OF REMOVAL

E36GBAF

4. REMOVAL OF PARKING BRAKE LEVER

Release the latch holding the cable to the parking brake lever and remove the parking brake lever.

5. REMOVAL OF HEAT PROTECTOR

Remove the heat protector attaching bolt, and move the heat protector to the rear of the vehicle.

INSPECTION

E36GCAC

- Abrasion on the parking brake lever latch
- Defective or malfunctioning parking brake cable

PARKING BRAKE SWITCH OPERATION CHECK

Disconnect the parking brake switch and connect circuit tester as shown in the figure.

The parking brake switch is correct if circuit continuity exists with the parking brake lever pulled, and no continuity when the parking brake lever is restored.

SERVICE POINTS OF INSTALLATION

E36GDAF

8. INSTALLATION OF PARKING BRAKE CABLE

- (1) Fit the positioning nails of the parking brake cable clamps into the body holes and fix.

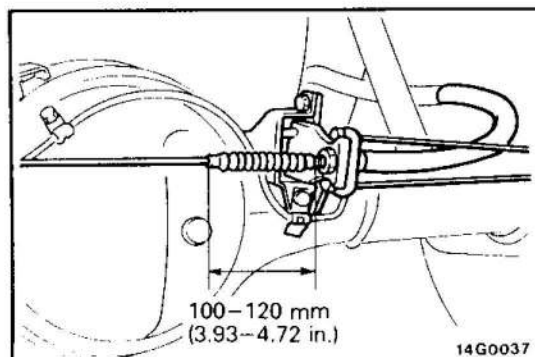
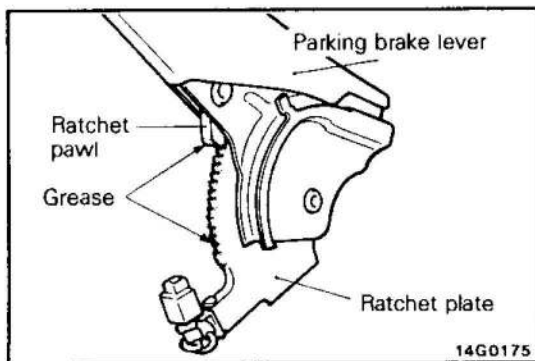

4. APPLICATION OF GREASE TO PARKING BRAKE LEVER

Apply specified grease to the sliding part between the parking brake lever ratchet pawl and ratchet plate teeth.

Specified grease: Multipurpose grease SAE J310, NLGI No.2

• CONFIRMATION OF THE PARKING BRAKE CABLE BOOT FIXING POSITION

Confirm parking brake boot has the dimension given in the figure with the parking brake lever assembly restored.

NOTE

1. If the boot attaching dimension is too long, the boot may come out of the parking brake cable outer cable as the brake is used, allowing moisture to enter the cable and the cable to subsequently stick.
2. When the boot length is not as indicated in the figure, adjust the length by moving the caulking at the boot tip.

