

EMISSION CONTROL

CONTENTS

E17AA--

GENERAL INFORMATION	2	SERVICE ADJUSTMENT PROCEDURES (4G32, 4G33, 4G63 engines) – Vehicles built up to May 1994	8
SPECIFICATIONS	2	SERVICE ADJUSTMENT PROCEDURES (4G92, 4G63 engines) – Vehicles with conventional carburetor built from June 1994	22-1
General Specifications – Vehicles built up to May 1994	2	SERVICE ADJUSTMENT PROCEDURES (G63B engine) – Vehicles built up to May 1994	23
General Specifications – Vehicles built from June 1994	4-2	SERVICE ADJUSTMENT PROCEDURES (4G92, 4G63 engines) – Vehicles with FBC built from June 1994	35-1
Service Specifications – Vehicles built up to May 1994	5	SERVICE ADJUSTMENT PROCEDURES (4G64, G64B engines) – Vehicles built up to May 1994	36
Service Specifications – Vehicles built from June 1994	5-1	SERVICE ADJUSTMENT PROCEDURES (4G63, 4G64 engines) – Vehicles with MPI built from June 1994	48-1
Torque Specifications – Vehicles built up to May 1994	5-2	SERVICE ADJUSTMENT PROCEDURES (4D56 engine)	48-11
Torque Specifications – Vehicles built from June 1994	5-2	CATALYTIC CONVERTER	49
Sealants and Adhesive	5-2		
SPECIAL TOOL	5-2		
TROUBLESHOOTING	6		

GENERAL INFORMATION

E17BAAG

The emission control system has the following three major systems.

- The crankcase emission control system is a system adopting a closed-type crankcase ventilation to prevent blow-by gas from escaping into the atmosphere. The blow-by gas generated in the crankcase is instead led to the combustion chamber for combustion.
- The evaporative emission control system for preventing the emission of fuel vapor from the fuel tank, etc. into the atmosphere consists of various components (a canister, purge control valve, 2-way valve and so on) which collect and lead generated fuel vapor to the combustion chamber for combustion.
- The exhaust emission control system consists of an air-fuel ratio control unit (FBC system and MPI system), three-catalyst converter, exhaust gas recirculation system, secondary air supply system and so on to reduce emission of CO, HC and NOx.

SPECIFICATIONS

E17CA--

GENERAL SPECIFICATIONS – Vehicles built up to May 1994

VEHICLES FOR EUROPE

4G32, 4G63 engines

Name		Specification
Crankcase emission control system	Positive crankcase ventilation (PCV) valve	Variable flow type (Purpose: HC reduction)
Evaporative emission control system	<ul style="list-style-type: none"> • Canister • 2-way valve • Purge control valve (PCV) • Outer vent valve (OVV) 	– – Single diaphragm type With temperature control
Exhaust emission control system	Exhaust gas recirculation system	Single type Bimetal type (Purpose: NOx reduction)
	Secondary air supply system Reed valve	With air control valve (Purpose: CO, HC reduction)
	Air intake temperature control system	Vacuum control type (Purpose: CO, HC reduction)

4G64 engines

Name		Specification
Crankcase emission control system	Positive crankcase ventilation (PCV) valve	Variable flow type (Purpose: HC reduction)
Evaporative emission control system	<ul style="list-style-type: none"> • Canister • 2-way valve • Purge control solenoid valve 	– – ON-OFF solenoid valve (Purpose: HC reduction)
Exhaust emission control system	Exhaust gas recirculation system	Single type Bimetal type (Purpose: NOx reduction)
	Air-fuel ratio control device-MPI system	Oxygen sensor feedback type (Purpose: CO, HC, NOx reduction)
	Three-way catalytic converter	Monolith type (Purpose: CO, HC, NOx reduction)

G63B engines

Name	Specification	
Crankcase emission control system	Positive crankcase ventilation (PCV) valve Variable flow type (Purpose: HC reduction)	
Evaporative emission control system	<ul style="list-style-type: none"> • Canister • 2-way valve • Purge control valve (PCV) • Bowl vent valve (BVV) – – Single diaphragm type Vacuum type (Purpose: HC reduction)	
Exhaust emission control system	Flow-control combustion system	Jet swirl system (Purpose: CO reduction)
	Air-fuel ratio control device-FBC system	Oxygen sensor feedback type (Purpose: CO, HC, NOx reduction)
	Three-way catalytic converter	Monolith type (Purpose: CO, HC, NOx reduction)
	Secondary air supply system Reed valve Secondary air control valve	With air control valve ON-OFF solenoid valve (Purpose: CO, HC reduction)
	Exhaust gas recirculation system EGR valve Vacuum regulator valve (VRV) Thermo valve	Single type With vacuum control Wax type (Purpose: NOx reduction)
	Intake air temperature control system	Vacuum control type (Purpose: CO, HC reduction)
Mixture control valve (MCV)	Pressure differential type valve (Purpose: CO, HC reduction)	

G64B engines

Name	Specification	
Crankcase emission control system	Positive crankcase ventilation (PCV) valve Variable flow type (Purpose: HC reduction)	
Evaporative emission control system	<ul style="list-style-type: none"> • Canister • 2-way valve • Purge control solenoid valve – – ON-OFF solenoid valve (Purpose: HC reduction)	
Exhaust emission control system	Flow-control combustion system	Jet swirl system (Purpose: CO reduction)
	Air-fuel ratio control device-MPI system	Oxygen sensor feedback type (Purpose: CO, HC, NOx reduction)
	Three-way catalytic converter	Monolith type (Purpose: CO, HC, NOx reduction)
	Exhaust gas recirculation system EGR valve Thermo valve	Single type Bimetal type (Purpose: NOx reduction)

4D56 engines (Vehicles with turbocharger for Switzerland built from November, 1990)

Name	Specification
Exhaust emission control system	Exhaust gas recirculation system EGR valve EGR control solenoid valve
	Single type ON-OFF and Duty solenoid valve

VEHICLES FOR GENERAL EXPORT

Name	Specification
Crankcase emission control system	Positive crankcase ventilation (PCV) valve
	Variable flow type (Purpose: HC reduction)
Evaporative emission control system	<ul style="list-style-type: none"> ● Canister ● 2-way valve ● Purge control valve
	– – Single diaphragm type

VEHICLES FOR HONG KONG BUILT FROM JULY 1991**4G33 engines**

Name	Specification
Crankcase emission control system	Positive crankcase ventilation (PCV) valve
	Variable flow type (Purpose: HC reduction)
Evaporative emission control system	<ul style="list-style-type: none"> ● Canister ● 2-way valve ● Purge control valve (PCV) ● Outer vent valve (OV)
	– – Single diaphragm type With temperature control
Exhaust emission control system	Exhaust gas recirculation system
	<ul style="list-style-type: none"> ● EGR valve ● Thermo-valve ● Vacuum regulator valve (VRV) with vacuum control
	Single type Wax type (Purpose: NOx reduction)
	Secondary air supply system
	Reed valve
	With air control valve (Purpose: CO, HC reduction)
	Air intake temperature control system
	Vacuum control type (Purpose: CO, HC reduction)

4G64 engines

Name	Specification
Crankcase emission control system	Positive crankcase ventilation (PCV) valve
	Variable flow type (Purpose: HC reduction)
Evaporative emission control system	<ul style="list-style-type: none"> ● Canister ● 2-way valve
	– –
Exhaust emission control system	Air-fuel ratio control device-MPI system
	Three-way catalytic converter
	Oxygen sensor feedback type (Purpose: CO, HC, NOx reduction)
	Monolith type (Purpose: CO, HC, NOx reduction)

VEHICLES FOR GULF COUNTRIES

Name		Specification
Crankcase emission control system	Positive crankcase ventilation (PCV) valve	Variable flow type (Purpose: HC reduction)
Evaporative emission control system	<ul style="list-style-type: none"> • Canister • 2-way valve • Purge control valve 	– – Single diaphragm type
Exhaust emission control system	Exhaust gas recirculation system EGR valve Thermo valve	<ul style="list-style-type: none"> • Single type • Bimetal type (Purpose: HC reduction)

**VEHICLES FOR AUSTRALIA
4G63 engines**

Name		Specification
Crankcase emission control system	Positive crankcase ventilation (PCV) valve	Variable flow type (Purpose: HC reduction)
Evaporative emission control system	<ul style="list-style-type: none"> • Canister • 2-way valve • Purge control valve (PCV) • Bowl vent valve (BVV) 	– – Single diaphragm type Vacuum type
Exhaust emission control system	Exhaust gas recirculation system EGR valve Thermo valve Vacuum regulator valve (VRV)	<ul style="list-style-type: none"> • Single type • Wax type • With vacuum control (Purpose: NOx reduction)
	Secondary air supply system Reed valve	With air control valve (Purpose: CO, HC reduction)
	Intake air temperature control system	Vacuum control type (Purpose: CO, HC reduction)

4G64 engines

Name		Specification
Crankcase emission control system	Positive crankcase ventilation (PCV) valve	Variable flow type (Purpose: HC reduction)
Evaporative emission control system	<ul style="list-style-type: none"> • Canister • 2-way valve • Purge control solenoid valve 	– – ON-OFF solenoid valve (Purpose: HC reduction)
Exhaust emission control system	Air-fuel ratio control device-MPI system	Oxygen sensor feedback type (Purpose: CO, HC, NOx reduction)
	Three-way catalytic converter	Monolith type (Purpose: CO, HC, NOx reduction)

**GENERAL SPECIFICATIONS – Vehicles built from June 1994
VEHICLES FOR EUROPE**
4G63 – Conventional Carburetor

Name		Specification
Crankcase emission control system	Positive crankcase ventilation (PCV) valve	Variable flow type (Purpose: HC reduction)
Evaporative emission control system	<ul style="list-style-type: none"> • Canister • 2-way valve • Bowl vent valve (BVV) 	– – Vacuum type

4G63 – FBC

Name		Specification
Crankcase emission control system	Positive crankcase ventilation (PCV) valve	Variable flow type (Purpose: HC reduction)
Evaporative emission control system	<ul style="list-style-type: none"> • Canister • 2-way valve • Purge control solenoid valve • Bowl vent valve (BVV) 	– – Single diaphragm type Vacuum type (Purpose: HC reduction)
Exhaust emission control system	Air-fuel ratio control device-FBC system	Oxygen sensor feedback type (Purpose: CO, HC, NOx reduction)
	Three-way catalytic converter	Monolith type (Purpose: CO, HC, NOx reduction)
	Secondary air supply system Reed valve Secondary air control valve	With air control valve ON-OFF solenoid valve (Purpose: CO, HC reduction)
	Exhaust gas recirculation system EGR valve Vacuum regulator valve (VRV) Thermo valve	Single type With vacuum control Wax type (Purpose: NOx reduction)
	Intake air temperature control system	Vacuum control type (Purpose: CO, HC reduction)

4G63 – MPI

Name		Specification
Crankcase emission control system	Positive crankcase ventilation (PCV) valve	Variable flow type (Purpose: HC reduction)
Evaporative emission control system	<ul style="list-style-type: none"> • Canister • 2-way valve • Purge control solenoid valve 	– – ON-OFF solenoid valve (Purpose: HC reduction)
Exhaust emission control system	Air-fuel ratio control device-MPI system	Oxygen sensor feedback type (Purpose: CO, HC, NOx reduction)
	Three-way catalytic converter	Monolith type (Purpose: CO, HC, NOx reduction)
	Exhaust gas recirculation system EGR valve EGR control solenoid valve	Single type Duty cycle solenoid valve (Purpose: NOx reduction)

4D56

Name		Specification
Exhaust emission control system	Exhaust gas recirculation system EGR valve EGR control solenoid valve	Single type ON-OFF and Duty Solenoid valve

VEHICLES FOR GENERAL EXPORT

4G92 – Conventional Carburetor

Name		Specification
Crankcase emission control system	Positive crankcase ventilation (PCV) valve	Variable flow type (Purpose: HC reduction)
Evaporative emission control system	<ul style="list-style-type: none"> ● Canister ● 2-way valve ● Bowl vent valve (BVV) 	– – Vacuum type

4G63 – Conventional Carburetor

Name		Specification
Crankcase emission control system	Positive crankcase ventilation (PCV) valve	Variable flow type (Purpose: HC reduction)
Evaporative emission control system	<ul style="list-style-type: none"> ● Canister ● 2-way valve ● Bowl vent valve (BVV) 	– – Vacuum type
Exhaust emission control system	Exhaust gas recirculation system*1 EGR valve Thermo valve	<ul style="list-style-type: none"> ● Single type ● Bimetal type (Purpose: HC reduction)
	High altitude compensation (HAC) system*2 High altitude compensator (HAC)	Bellows type (Purpose: CO, HC reduction)

NOTE

*1: Vehicles for Gulf countries

*2: Vehicles for Columbia, Bolivia and Ecuador

4G92 – FBC

	Name	Specification
Crankcase emission control system	Positive crankcase ventilation (PCV) valve	Variable flow type (Purpose: HC reduction)
Evaporative emission control system	<ul style="list-style-type: none"> ● Canister ● 2-way valve ● Bowl vent valve (BVV) 	– – Vacuum type (Purpose: HC reduction)
Exhaust emission control system	Air-fuel ratio control device-FBC system	Oxygen sensor feedback type (Purpose: CO, HC, NOx reduction)
	Three-way catalytic converter	Monolith type (Purpose: CO, HC, NOx reduction)
	Exhaust gas recirculation system EGR valve Thermo valve	Single type Wax type (Purpose: NOx reduction)
	Intake air temperature control system	Vacuum control valve (Purpose: CO, HC reduction)

4G63 – MPI

	Name	Specification
Crankcase emission control system	Positive crankcase ventilation (PCV) valve	Variable flow type (Purpose: HC reduction)
Evaporative emission control system	<ul style="list-style-type: none"> ● Canister ● 2-way valve ● Purge control solenoid valve 	– – ON-OFF solenoid valve (Purpose: HC reduction)
Exhaust emission control system	Air-fuel ratio control device-MPI system	Oxygen sensor feedback type (Purpose: CO, HC, NOx reduction)
	Three-way catalytic converter	Monolith type (Purpose: CO, HC, NOx reduction)
	Exhaust gas recirculation system EGR valve EGR control solenoid valve	Single type Duty cycle solenoid valve (Purpose: NOx reduction)

VEHICLES FOR AUSTRALIA
4G63 – Conventional Carburetor

	Name	Specification
Crankcase emission control system	Positive crankcase ventilation (PCV) valve	Variable flow type (Purpose: HC reduction)
Evaporative emission control system	<ul style="list-style-type: none"> ● Canister ● 2-way valve ● Bowl vent valve (BVV) 	– – Vacuum type
Exhaust emission control system	Exhaust gas recirculation system EGR valve Thermo valve Vacuum regulator valve (VRV)	<ul style="list-style-type: none"> ● Single type ● Wax type ● With vacuum control (Purpose: NOx reduction)
	Secondary air supply system Reed valve	With air control valve (Purpose: CO, HC reduction)
	Fuel cut-off device (during deceleration) Fuel cut solenoid valve Vacuum switch Engine speed sensor	ON-OFF solenoid valve Contact type switch Transistor relay (Purpose: CO, HC reduction)
	Three-way catalytic converter	Monolith type (Purpose: CO, HC, NOx reduction)
	Intake air temperature control system	Vacuum control type (Purpose: CO, HC reduction)

4G64 – MPI

	Name	Specification
Crankcase emission control system	Positive crankcase ventilation (PCV) valve	Variable flow type (Purpose: HC reduction)
Evaporative emission control system	<ul style="list-style-type: none"> ● Canister ● 2-way valve 	– –
Exhaust emission control system	Air-fuel ratio control device-MPI system	Oxygen sensor feedback type (Purpose: CO, HC, NOx reduction)
	Three-way catalytic converter	Monolith type (Purpose: CO, HC, NOx reduction)

17-4-6

NOTES

SERVICE SPECIFICATIONS – Vehicles built up to May 1994

E17CB--

Items	Specifications
Standard value	
4G32, 4G33, 4G63 engines	
EGR valve opening pressure mmHg (in.Hg)	
Vehicles to Europe and General Export	60 (2.36)
Vehicles for Australia	70 (2.76)
Purge control valve opening pressure mmHg (in.Hg)	35 (1.38)
Thermo valve opening temperature	
Vehicles for Europe and General Export	70°C (158°F)
Vehicles for Australia	50°C (122°F)
G63B engines	
EGR valve opening pressure mmHg (in.Hg)	70 (2.76)
Purge control valve opening pressure mmHg (in.Hg)	200 (7.87)
Thermo valve opening temperature	65°C (149°F)
Secondary air control solenoid valve coil resistance [at 20°C (68°F)] Ω	38-44
4G64, G64B engine	
Purge control solenoid valve coil resistance [at 20°C (68°F)] Ω	38-44
Thermo valve opening temperature	40°C (104°F)
4D56 engine (Vehicles with turbocharger for Switzerland built from November, 1990)	
EGR control solenoid valve No. 1 and No. 2 resistance [at 20°C (68°F)] Ω	36 - 44
Lever position sensor output voltage	
Idle position	0.3 - 1.5
Full open	3.7 - 4.9
Speed sensor resistance Ω	1.3 - 1.9
Engine coolant temperature sensor resistance [at 20°C (68°F)] kΩ	3.3
[at 80°C (176°F)] kΩ	0.3

SERVICE SPECIFICATIONS – Vehicles built from June 1994

Items		Specifications
Standard value		
4G92, 4G63 engines (Conventional carburetor)		
EGR valve opening pressure	mmHg (in.Hg)	
Vehicles for Gulf countries		60 (2.36)
Vehicles for Australia		70 (2.76)
Thermo valve opening temperature	°C (°F)	
Vehicles for Gulf countries		70 (158)
Vehicles for Australia		
EGR valve control		70 (158)
Secondary air control		18 (65.4)
4G92, 4G63 engines (FBC)		
EGR valve opening pressure	mmHg (in.Hg)	
4G92 engine		60 (2.36)
4G63 engine		70 (2.76)
Purge control valve opening pressure	mmHg (in.Hg)	35 (1.38)
Thermo valve opening temperature	°C (°F)	
4G92 engine		70 (158)
4G63 engine		65 (149)
Secondary air control solenoid valve coil resistance [at 20°C (68°F)]	Ω	38 – 44
4G63, 4G64 engines (MPI)		
EGR valve opening pressure	mmHg (in.Hg)	60 (2.36)
EGR control solenoid valve coil resistance [at 20°C (68°F)]	Ω	36 – 44
Purge control solenoid valve coil resistance [at 20°C (68°F)]	Ω	36 – 44
4D56		
EGR control solenoid valve No. 1 coil resistance [at 20°C (68°F)]	Ω	36 – 44
EGR control solenoid valve No. 2 coil resistance [at 20°C (68°F)]	Ω	36 – 44
Lever position sensor output voltage	V	
Idle position		0.3 – 1.5
Full open		3.7 – 4.9
Speed sensor resistance	kΩ	1.3 – 1.9
Engine coolant temperature sensor resistance	kΩ	
At 20°C (68°F)		3.3
At 80°C (176°F)		0.3

TORQUE SPECIFICATIONS – Vehicles built up to May 1994

E17CC--

Items	Nm	kgm	ft.lbs.
Thermo valve	20-40	2.0-4.0	15-29
EGR valve	19-28	1.9-2.8	14-20
Front exhaust pipe to catalytic converter			
Type A	50-70	5.0-7.0	36-50
Type B	30-40	3.0-4.0	22-29
Catalytic converter to main muffler			
Type A	30-40	3.0-4.0	22-29
Type B	50-70	5.0-7.0	36-50

TORQUE SPECIFICATIONS – Vehicles built from June 1994

Items	Nm	kgm	ft.lbs.
Thermo valve			
Single nipple type	20-50	2.0-5.0	15-36
Except single nipple type	20-40	2.0-4.0	15-29
EGR valve	17-26	1.7-2.6	12-19
Front exhaust pipe to catalytic converter			
Type A	50-70	5.0-7.0	36-50
Type B	30-40	3.0-4.0	22-29
Catalytic converter to main muffler			
Type A	30-40	3.0-4.0	22-29
Type B	50-70	5.0-7.0	36-50

SEALANTS AND ADHESIVE

E17CE--

Item	Specified sealant and adhesive	Quantity
Thermo valve thread	3M NUT LOCKING Part No. 4171 or equivalent	As required

SPECIAL TOOL

E17DA--

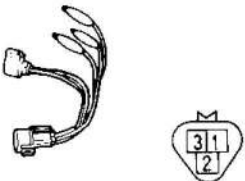
Tool	Number	Name	Use
	MD998478	Test harness	Lever position sensor inspection

TROUBLESHOOTING

E17EAAA

4G32, 4G33, 4G63, 4G92 ENGINES (Conventional Carburetor)

Symptom	Probable cause	Remedy	Reference page
Engine will not start or start to hard (Crank OK.)	EGR valve not closed	Repair or replace	17-19, 17-22-8
	Vacuum hose disconnected or damaged	Repair or replace	-
Rough idle or engine stalls	Faulty purge control system	Inspect the system and, if found to be faulty, inspect the component parts	17-14
	EGR valve not closed	Repair or replace	17-19, 17-22-8
	Vacuum hose disconnected or damaged	Repair or replace	-
	Faulty PCV valve	Replace	-
	Faulty intake air temperature control system (carburetor icing)	Inspect the system and, if found to be faulty, inspect the component parts.	17-21, 17-22-10
Engine hesitates or poor acceleration	Faulty exhaust gas recirculation system	Inspect the system and, if found to be faulty, inspect the component parts.	17-17, 17-22-7
	Faulty thermo valve-cold engine	Replace	17-20, 17-22-9
	Faulty intake air temperature control system	Inspect the system and, if found to be faulty, inspect the component parts	17-21, 17-22-10
Excessive oil consumption	Positive crankcase ventilation line clogged	Check positive crankcase ventilation system	17-13, 17-22-7
Poor fuel mileage	Faulty exhaust gas recirculation system	Inspect the system and, if found to be faulty, inspect the component parts	17-17, 17-22-7
	Faulty intake air temperature control system	Inspect the system and, if found to be faulty, inspect the component parts	17-21, 17-22-10

G63B, 4G63, 4G92 ENGINES (FBC)

Symptom	Probable cause	Remedy	Reference page
Engine will not start or start to hard (Crank OK.)	EGR valve not closed	Repair or replace	17-34, 13-35-10
	Mixture control valve not closed	Replace	-
	Vacuum hose disconnected or damaged	Repair or replace	-
Rough idle or engine stalls	Vacuum hose disconnected or damaged	Repair or replace	-
	EGR valve not closed	Repair or replace	17-34, 13-35-10
	Faulty purge control system	Inspect the system and, if found to be faulty, inspect the component parts	17-28, 17-35-8
	Faulty bowl vent valve	Replace	17-30, 17-35-8
	Mixture control valve not closed	Replace	-
	Faulty PCV valve	Replace	17-29, 17-35-8
	Engine hesitates or poor acceleration	Faulty exhaust gas recirculation system	Inspect the system and, if found to be faulty, inspect the component parts
Faulty thermo valve-cold engine		Replace	17-29, 17-35-11
Faulty intake air temperature control system		Inspect the system and, if found to be faulty, inspect the component parts	17-35, 17-35-11

Symptom	Probable cause	Remedy	Reference page
Excessive oil consumption	Positive crankcase ventilation line clogged	Check positive crankcase ventilation system	17-28, 17-35-8
Poor fuel mileage	Faulty intake air temperature control system	Inspect the system and, if found to be faulty, inspect the component parts	17-35, 17-35-11
	Faulty exhaust gas recirculation system	Inspect the system and, if found to be faulty, inspect the component parts	17-33, 17-35-10

4G63, 4G64, G64B ENGINES (MPI)

Symptom	Probable cause	Remedy	Reference page
Engine will not start or start to hard	EGR valve not closed	Repair or replace	17-48, 17-48-9
	Vacuum hose disconnected or damaged	Repair or replace	-
	Faulty purge control solenoid valve	Repair or replace	17-45, 17-48-6
Rough idle of engine stalls	Vacuum hose disconnected or damaged	Repair or replace	-
	EGR valve not closed	Repair or replace	17-48, 17-48-9
	Faulty PCV valve	Replace	-
	Faulty purge control system	Inspect the system and, if found to be faulty, inspect the component parts	17-44, 17-48-5
Engine hesitates or poor acceleration	Faulty exhaust gas recirculation system	Inspect the system and, if found to be faulty, inspect the component parts	17-47, 17-48-8
Excessive oil consumption	Positive crankcase ventilation line clogged	Check positive crankcase ventilation system	17-43, 17-48-5
Poor fuel mileage	Faulty exhaust gas recirculation system	Inspect the system and, if found to be faulty, inspect the component parts	17-47, 17-48-8

SERVICE ADJUSTMENT PROCEDURES (4G32, 4G33, 4G63 engines) — Vehicles built up to May 1994

E17FE-0

VACUUM HOSE PIPING DIAGRAM

Vehicles for Europe

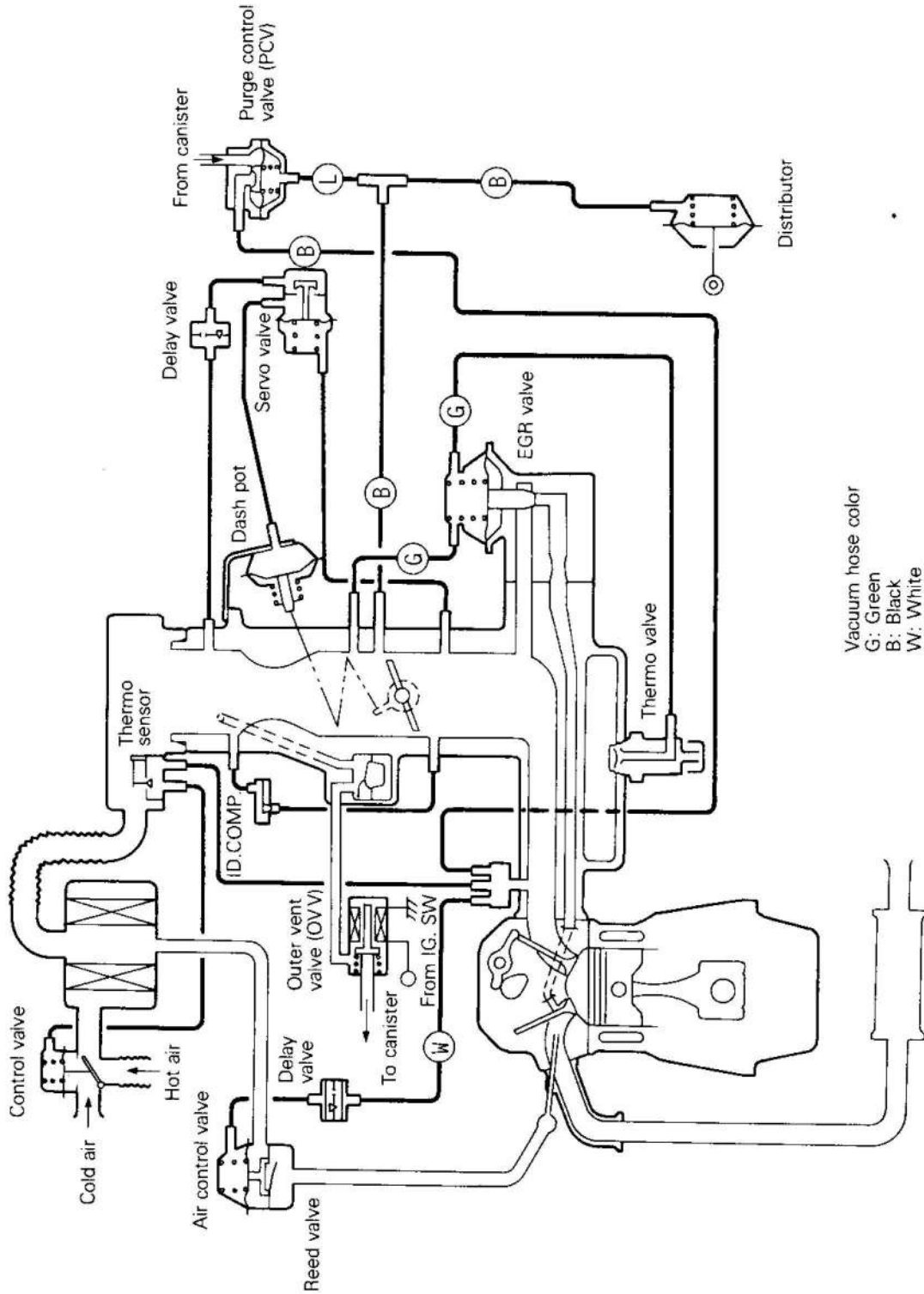

Vacuum hose color
G: Green
B: Black
W: White
L: Light blue

6EM0020

Vehicles for General Export and Gulf Countries

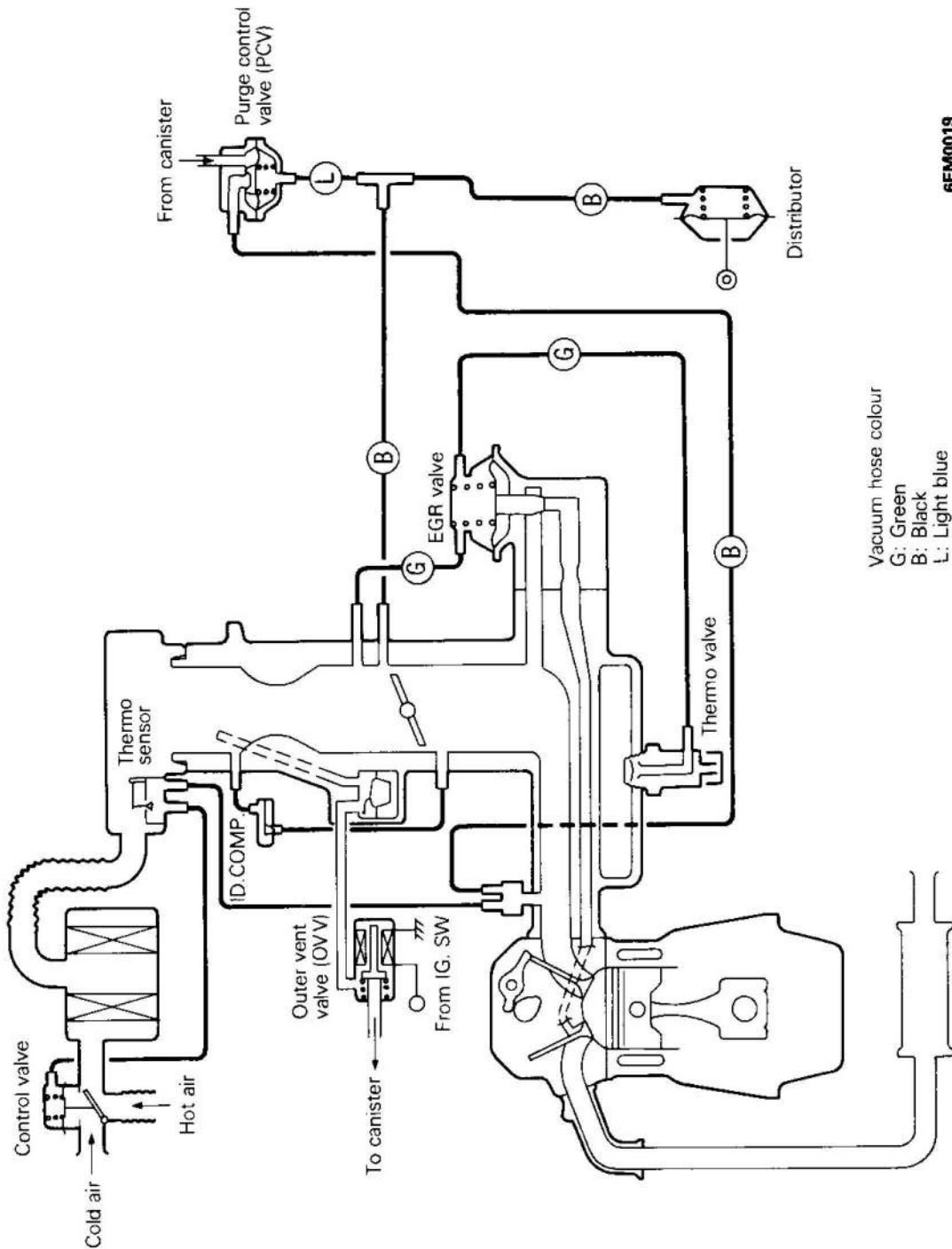

6EM0019

Vacuum hose colour
 G: Green
 B: Black
 L: Light blue

Vehicles for Hong Kong built from July 1991

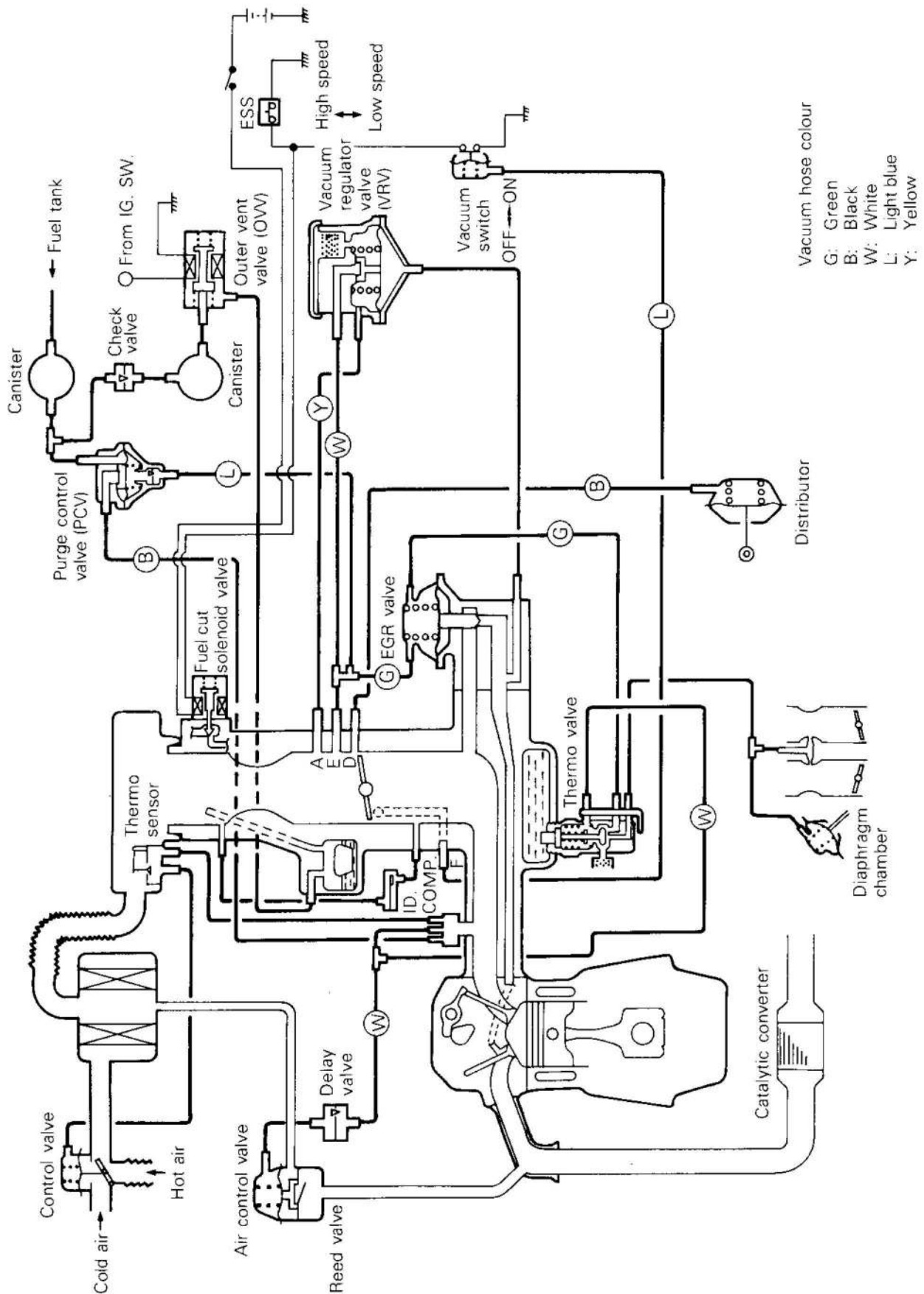

3EM0138

NOTE

Vehicles for Australia

Vehicles built up to June 1987

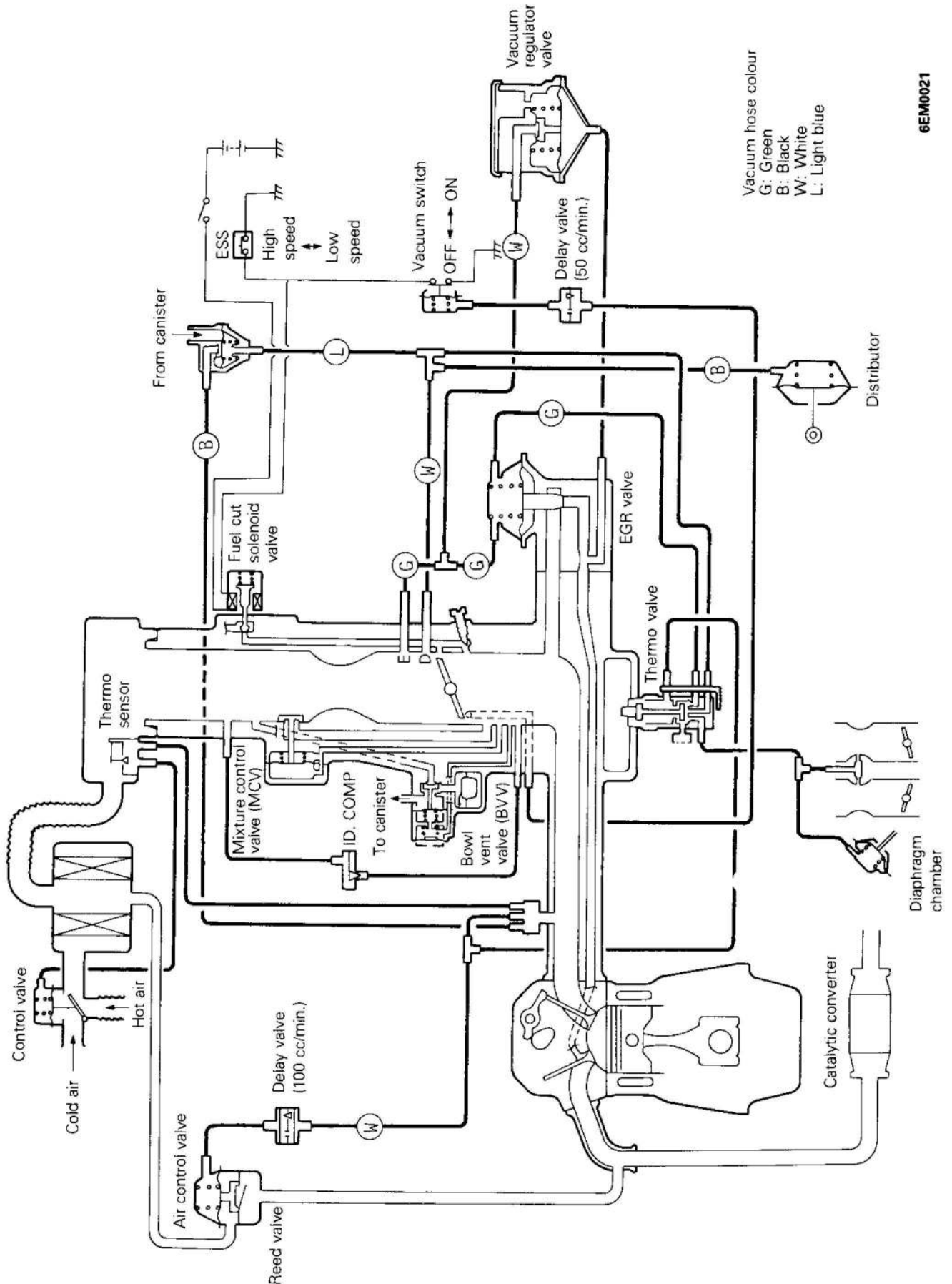

6EM0021

Vehicles built from July 1987

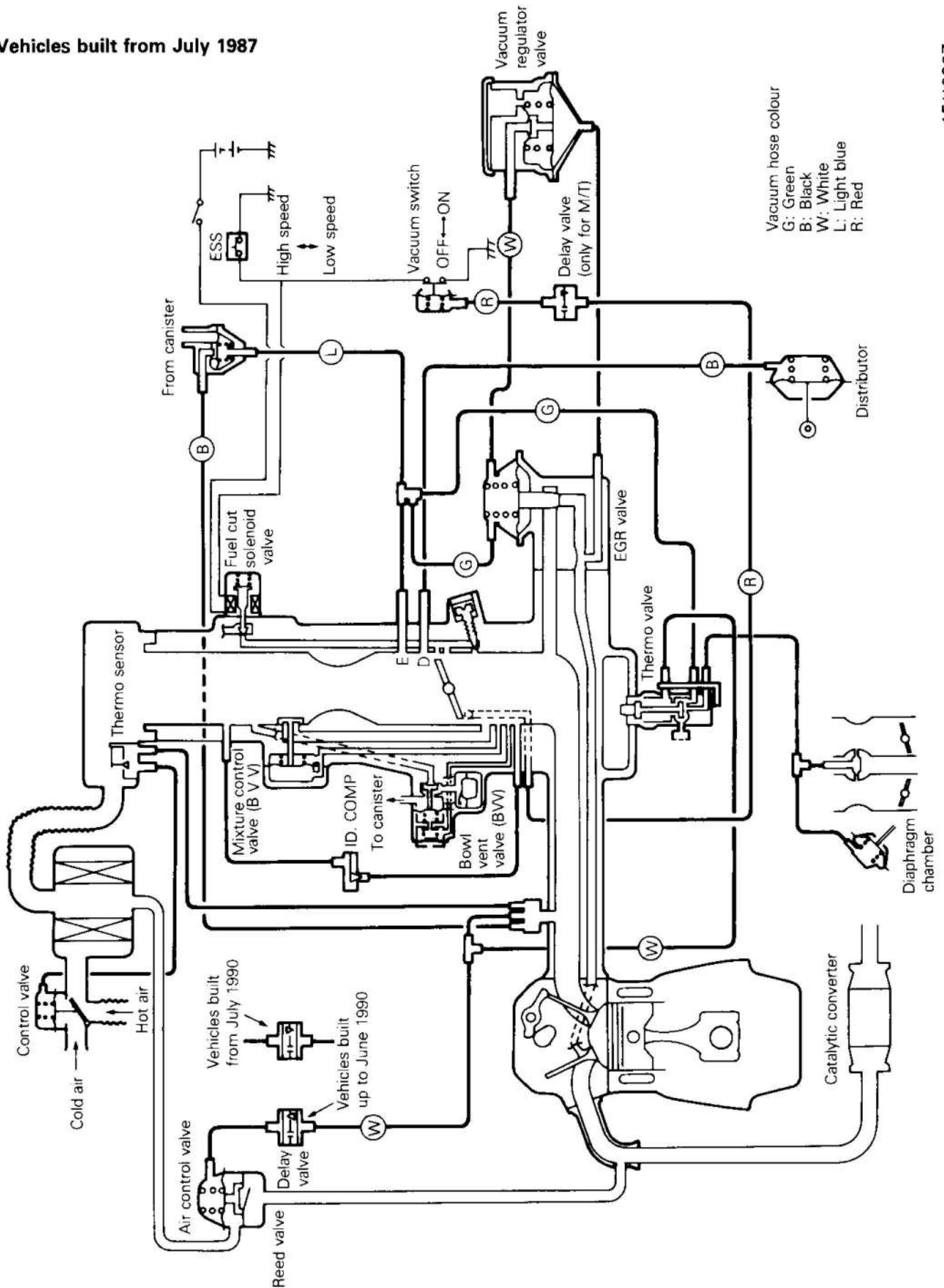

6EM0237

17-10-2

NOTES

VACUUM HOSE LAYOUT

Vehicles for Europe

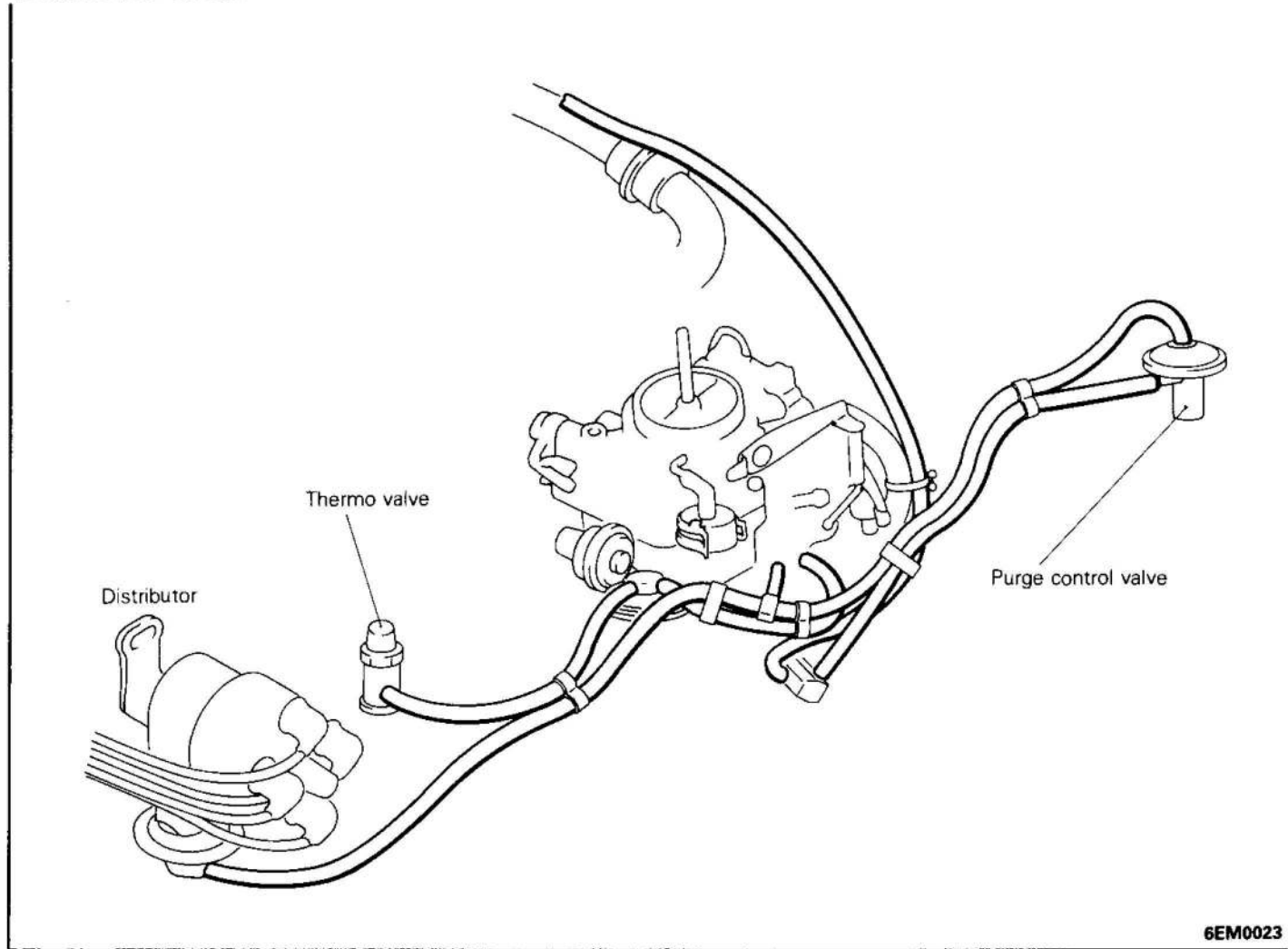

6EM0023

Vehicles for General Export and Gulf Countries

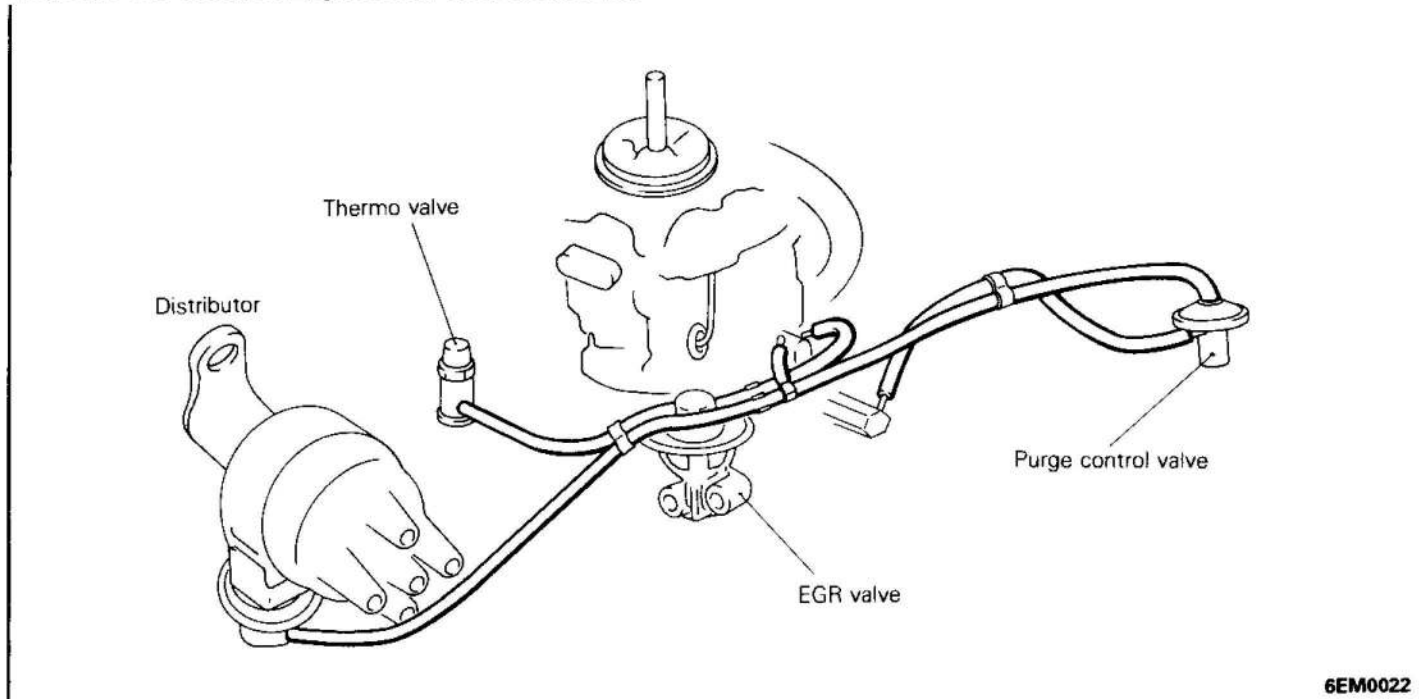

6EM0022

Vehicles for Australia

Vehicles built up to June 1987

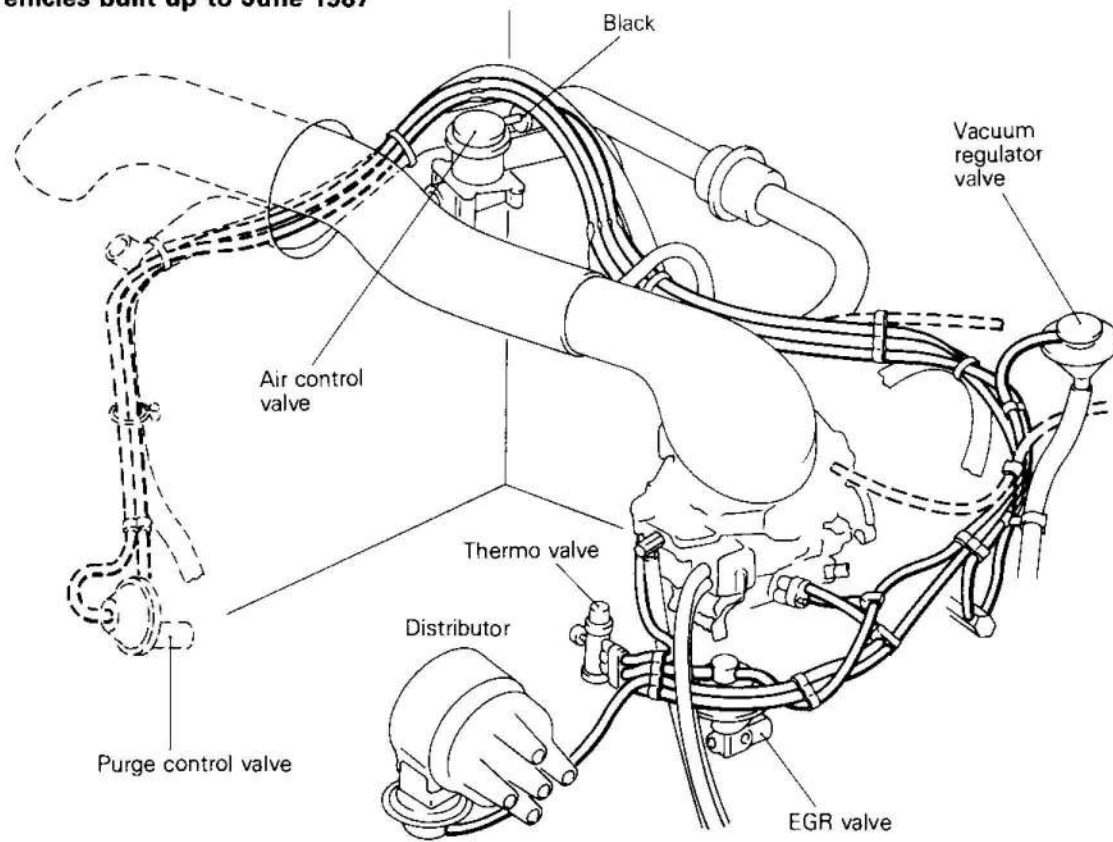

6EM0024

Vehicles built from July 1987

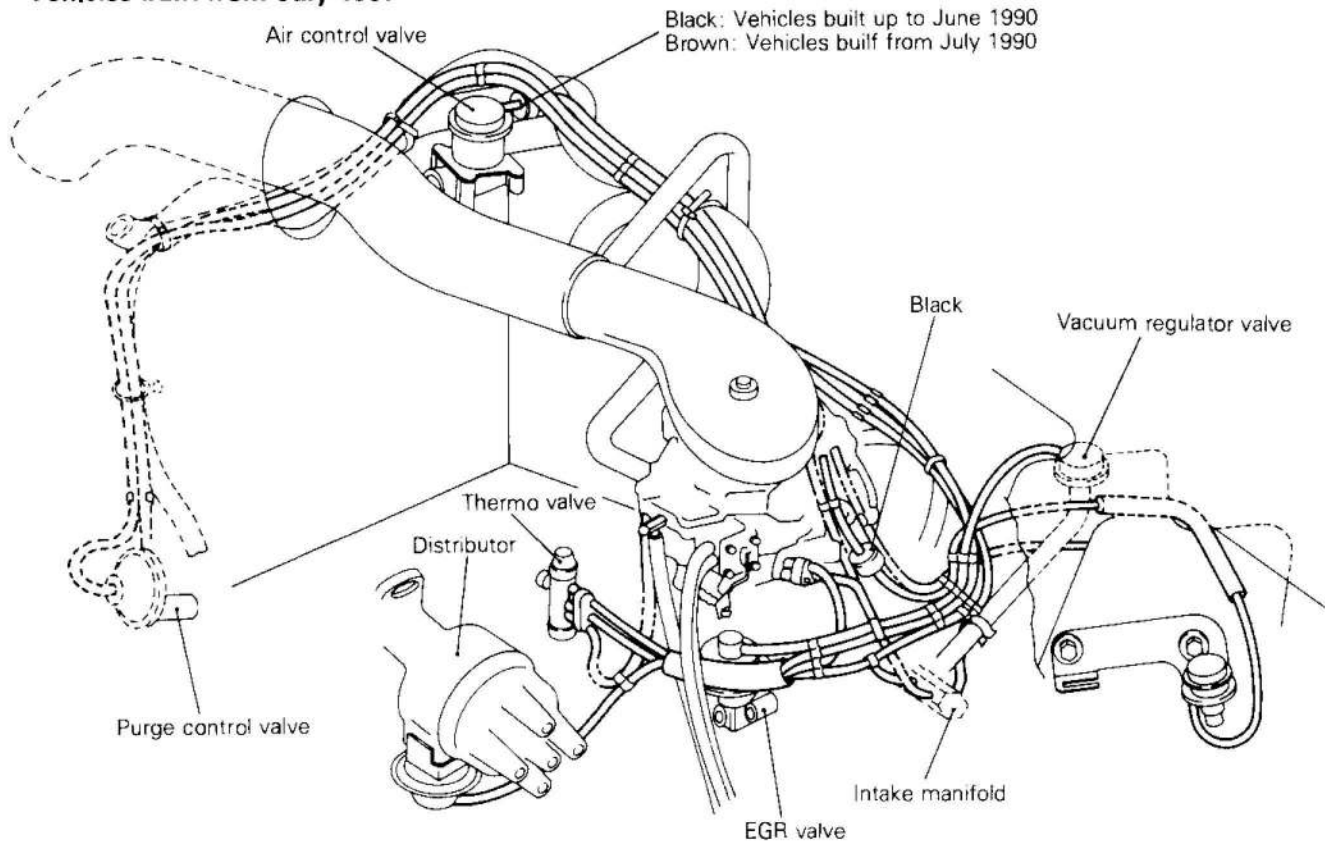

6EM0238

Vehicles for Hong Kong built from July 1991

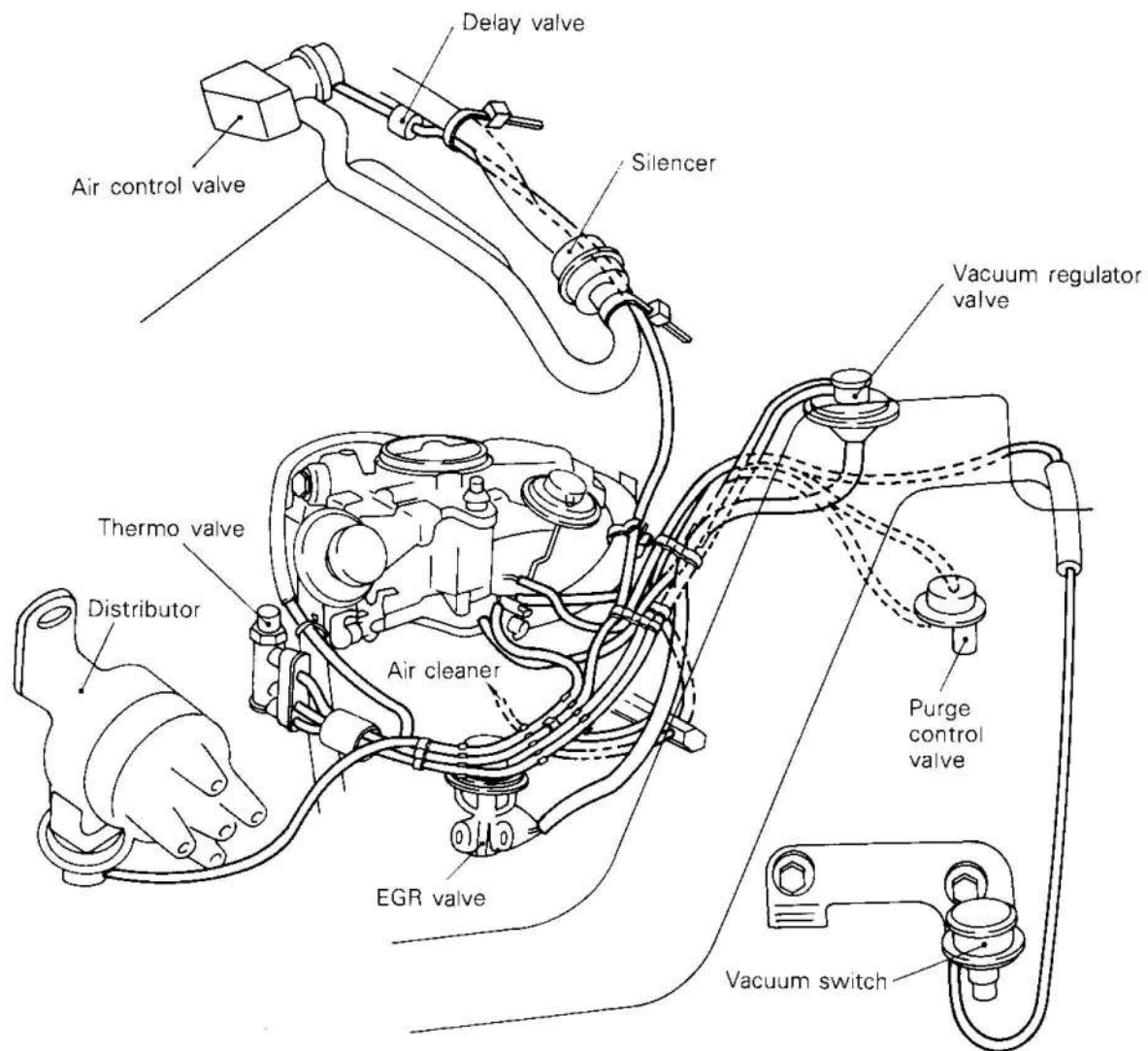

3EM0126

17-12-2 EMISSION CONTROL — Service Adjustment Procedures (4G32, 4G33, 4G63 engines)

NOTE

CAUTIONS ON INSPECTION

E17FFAA0

1. Inspect the various devices only after completing engine adjustment.
2. Inspect the hoses to make sure there are no disconnections, connection errors or damage.
3. Make sure there is no hose, pipe or port clogging, or cracks or damage in the hoses and pipes.
4. When replacing device hoses, always mount the replacement hose in the same position (direction) as the original.
5. When finished, check the connections as described in the service manual.

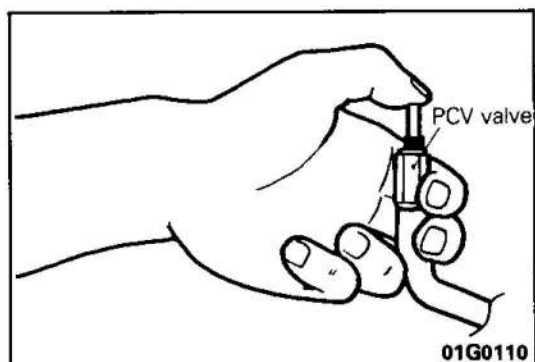
**CRANKCASE EMISSION CONTROL SYSTEM**

E17FAAB0

1. CHECKING OF PCV VALVE

- (1) After disconnecting the ventilation hose from the positive crankcase ventilation (PCV) valve, remove the PCV valve from the rocker cover and again connect the ventilation hose.
- (2) Run the engine at idling speed, place a finger over the end of the PCV valve opening and check the intake manifold vacuum.

NOTE

The plunger inside the PCV valve will move back and forth.

- (3) If vacuum cannot be felt against the finger, clean the PCV valve and ventilation hose with cleaning solvent, or else replace.

EVAPORATIVE EMISSION CONTROL SYSTEM

E17FBAC

1. CHECKING OF PURGE CONTROL SYSTEM (Vehicle for Europe and General Export)

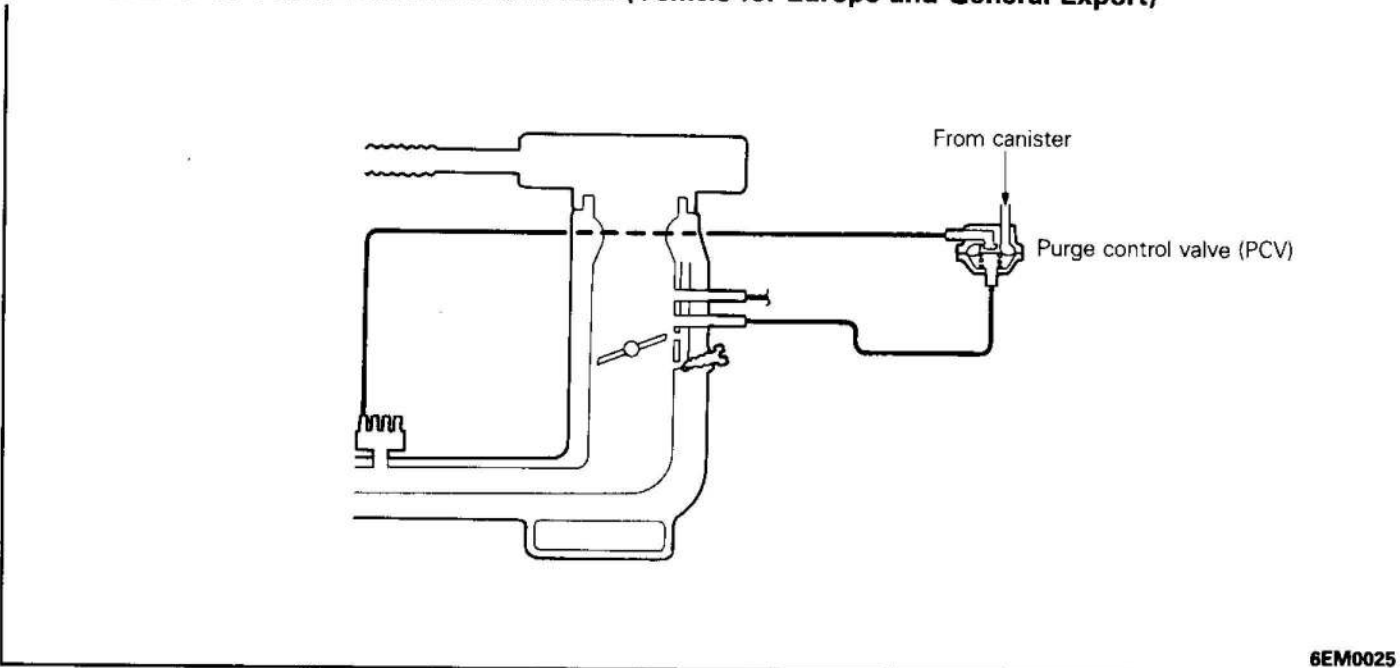

6EM0025

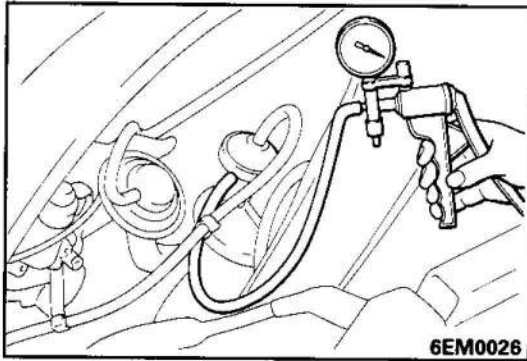

6EM0026

- (1) Disconnect the black vacuum hose from the intake manifold nipple and plug the nipple; then connect the disconnected black vacuum hose to a hand vacuum pump.
- (2) Apply vacuum to check the airtightness.

Engine status	Normal condition
Idling	Vacuum is maintained
2,500 r/min.	Vacuum leaks

2. CHECKING OF PURGE CONTROL SYSTEM (Vehicles for Australia and vehicles for Hong Kong built from July 1991)

Vehicles for Australia

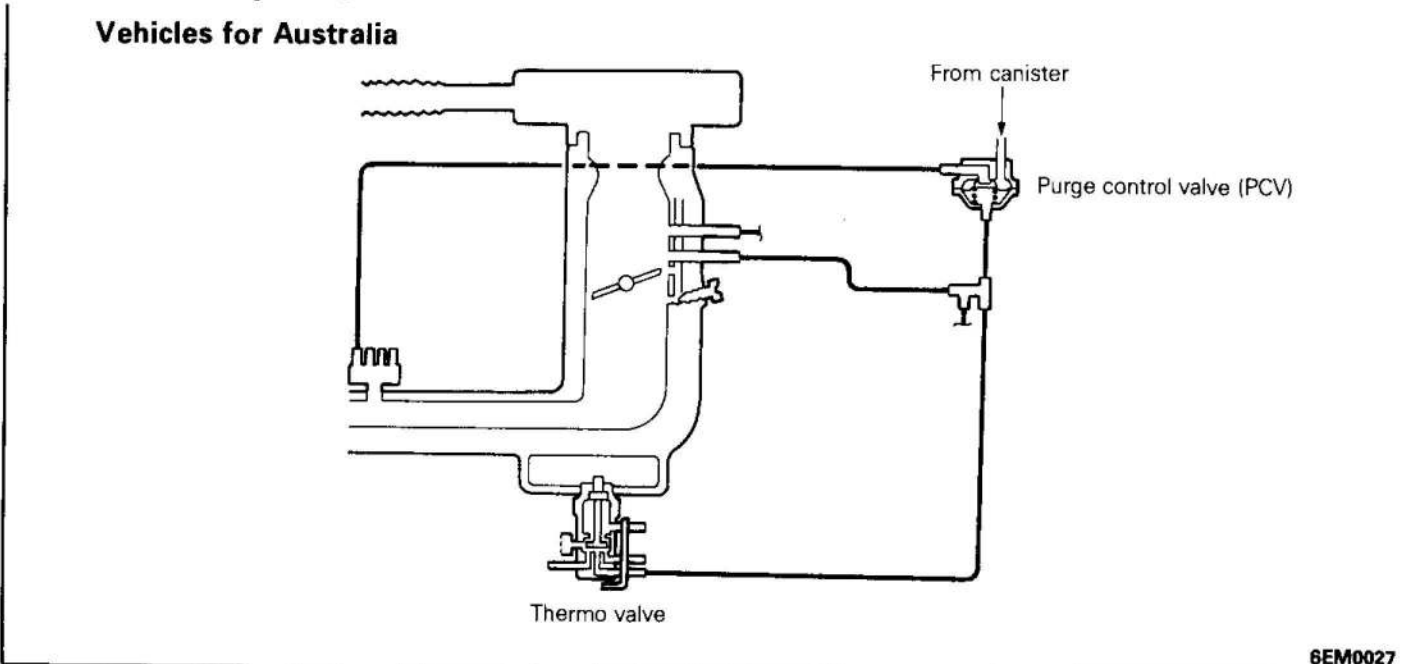

6EM0027

Vehicles for Hong Kong

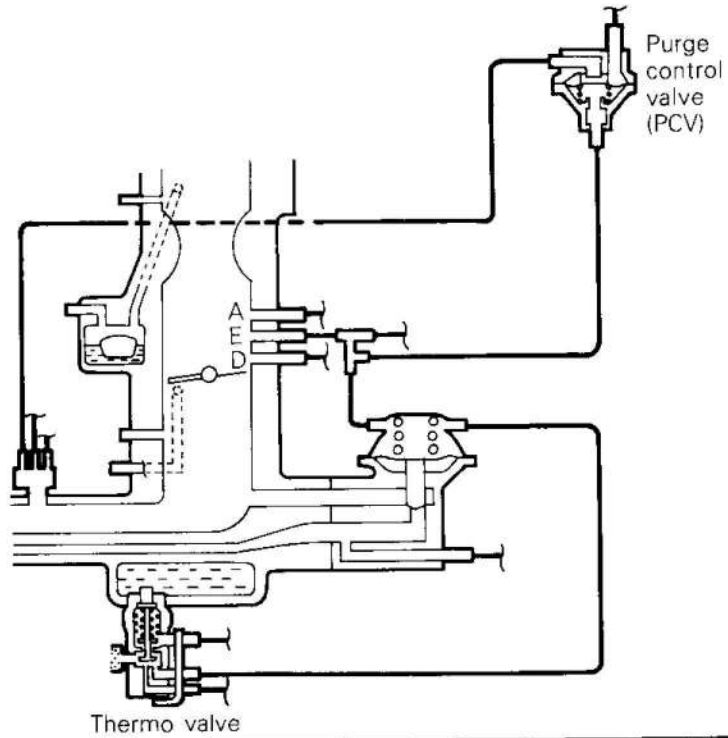

3EM0139

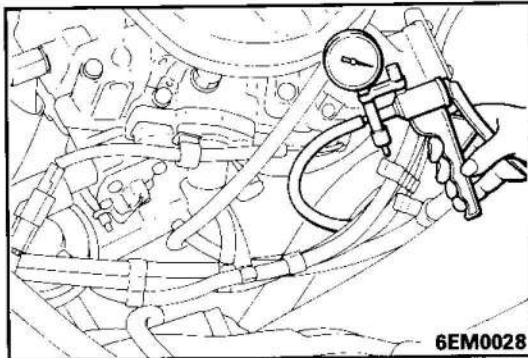

6EM0028

- (1) Disconnect the black vacuum hose from the intake manifold nipple and plug the nipple; then connect the disconnected black vacuum hose to a hand vacuum pump.
- (2) Inspect the following items with the engine cold [coolant temperature: 40°C (104°F) or less] and hot [coolant temperature: 80°C (176°F) or higher].

When engine is cold

Vacuum	Engine status	Normal condition
400 mmHg (15.7 in.Hg)	3,500 r/min	Vacuum is maintained

When engine is hot

Vacuum	Engine status	Normal condition
400 mmHg (15.7 in.Hg)	Idling	Vacuum is maintained
400 mmHg (15.7 in.Hg)	3,500 r/min	Vacuum leaks

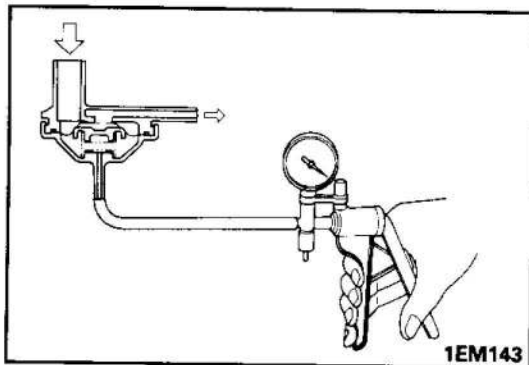

3. CHECKING OF PURGE CONTROL VALVE (PCV)

- (1) Remove the purge control valve.
- (2) Connect a hand vacuum pump to the nipple of the PCV.
- (3) Apply a vacuum of 400 mmHg (15.7 in.Hg) and make sure that airtightness is maintained.
- (4) check whether or not air is lightly blown out from the nipple on the canister side.

Hand vacuum pump vacuum	Normal condition
0 mmHg (0 in.Hg) (no vacuum)	Air is not blow out
200 mmHg (7.9 in.Hg)	Air is blown out

4. CHECKING OF OUTER VENT VALVE (Vehicles for Europe and General Export)

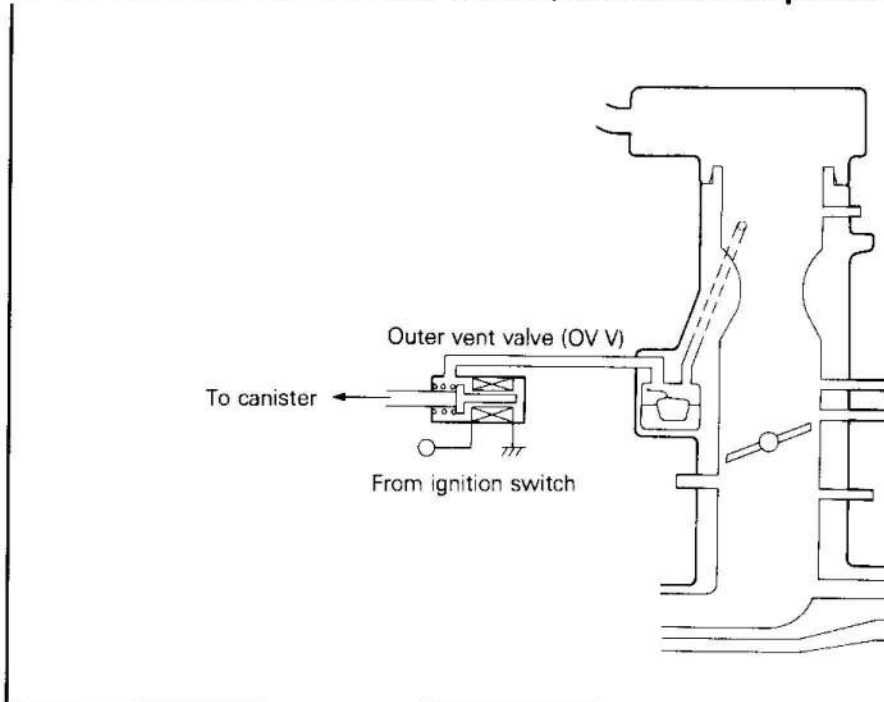

6EM0029

Caution

Use caution when the engine is hot because fuel may be discharged from the hose.

- (1) Disconnect the 2 vapor hoses from the outer vent valve (OVV) and connect them to a vacuum pump.
- (2) Apply a vacuum and check the passage of air through the OVV.

IG.S/W	Temperature	35°C (95°F) or less	70°C (158°F) or higher
	OFF		Vacuum is maintained
ON		Vacuum is maintained	Vacuum is maintained

5. CHECKING OF BOWL VENT VALVE (BVV) (Vehicles for Australia)

Caution

Inspect after the engine has scooled. Fuel may be discharged from the BVV nipple if the engine is still warm.

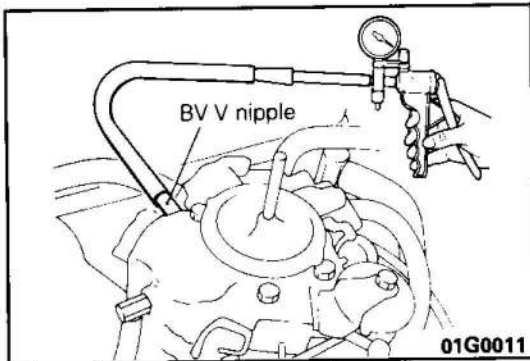
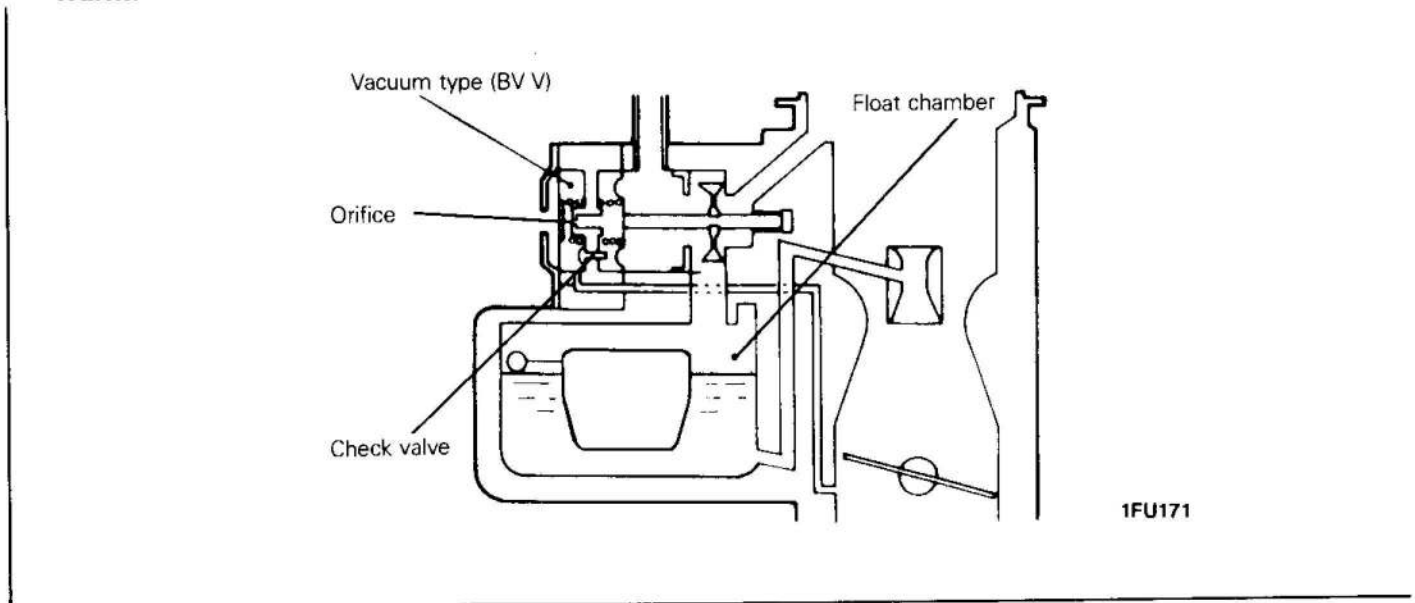

- (1) Remove the air horn.
- (2) Disconnect the bowl vapor hose from the bowl vent valve (BVV) nipple and connect a hand vacuum pump to the BVV nipple.
- (3) Apply a vacuum of 100 mmHg (3.9 in.Hg) to the BVV and inspect.

Engine status	Normal condition
STOP	Vacuum leaks
Idling	Vacuum is applied

EXHAUST EMISSION CONTROL SYSTEM

E17FCAE

1. CHECKING OF EGR SYSTEM (Vehicles for Europe and Gulf Countries)

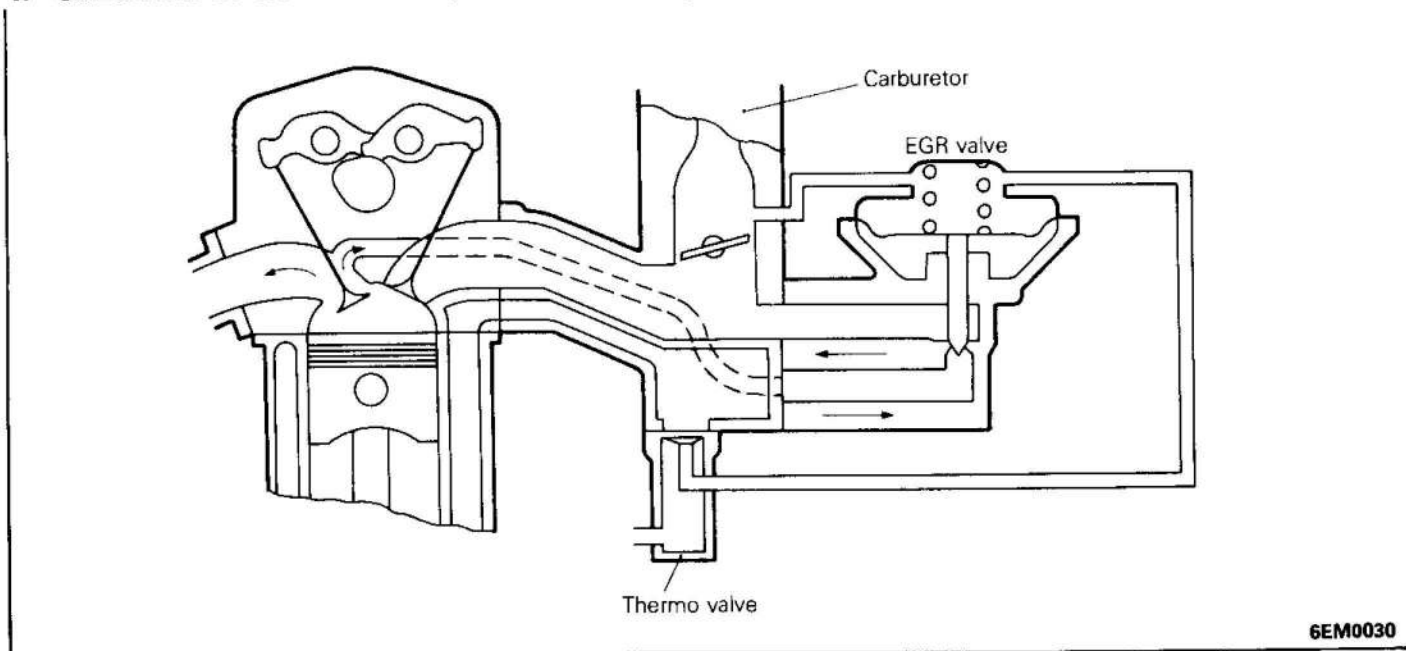

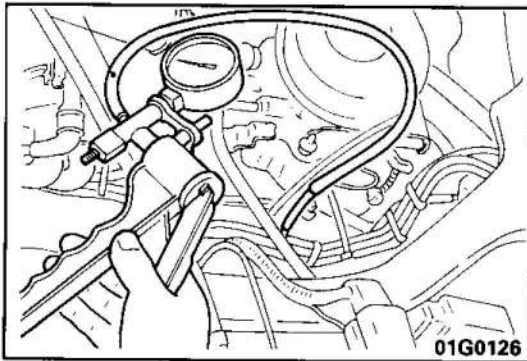

- (1) Disconnect the vacuum hose (green stripes) from the carburetor throttle body and connect the vacuum hose to a hand vacuum pump.
- (2) Inspect the following items with the engine cold [coolant temperature: 40°C (104°F) or less] and hot [coolant temperature: 80°C (176°F) or higher].

When engine is cold

Vacuum	Engine status	Normal condition
Try applying a vacuum	Idling	Vacuum leaks from the thermo valve

When engine is hot

Vacuum	Engine status	Normal Condition
40 mmHg (1.57 in.Hg) or less	Idling	Vacuum is maintained
150 mmHg (5.91 in.Hg) or more	Idling → somewhat unstable	Vacuum is maintained

2. CHECKING OF EGR SYSTEM (Vehicles for Australia and vehicles for Hong Kong built from July 1991)

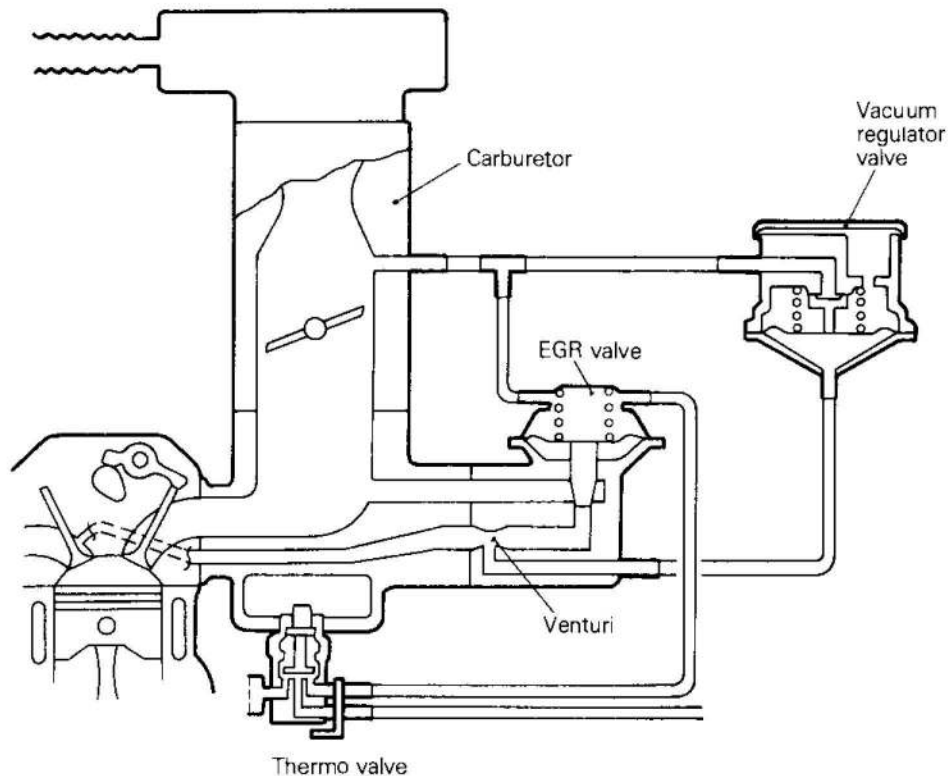

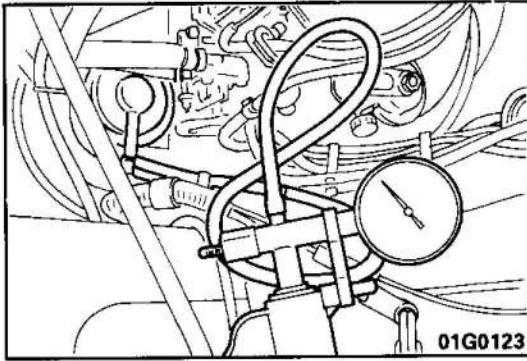

- (1) Disconnect the vacuum hose (green stripes) from the carburetor throttle body and connect the vacuum hose to a hand vacuum pump.
- (2) Inspect the following items with the engine cold and hot.

Engine cold

[coolant temperature: 40°C (104°F) or less]

Raise engine revolution to 3,500 r/min, apply vacuum	Vacuum leaks to atmosphere from thermo valve
--	--

Engine hot

[coolant temperature 80°C (176°F) or more]

	Engine	Normal condition
Apply vacuum	Idling	Vacuum leaks
	3,500 r/min.	Vacuum is maintained at approx. 80 mmHg (3.1 in.Hg)

3. CHECKING OF EGR VALVE (excluding Vehicles for General Export)

- (1) Remove the EGR valve and inspect for sticking, carbon deposits, etc. If found, clean with a suitable solvent so that the valve seats correctly.
- (2) Connect a hand vacuum pump to the EGR valve.
- (3) Plug the other nipple.
- (4) Apply a vacuum of 500 mmHg (19.7 in.Hg) and make sure that airtightness is maintained. Check whether or not air is blown out of the EGR air passage.

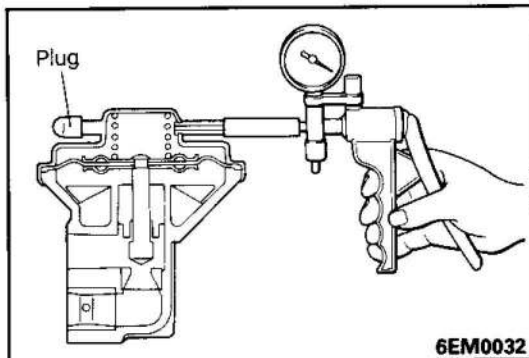

Vehicles for Europe (except P03W, P23V, P23W), Gulf Countries and Australia (With a manual transmission)

Vacuum	Normal condition
40 mmHg (1.57 in.Hg) or less	Air is not blown out
150 mmHg (5.91 in.Hg) or more	Air is blown out

Vehicles for Europe (P03W, P23V, P23W)

Vacuum	Normal condition
30 mmHg (1.18 in.Hg) or less	Air is not blown out
130 mmHg (5.12 in.Hg) or more	Air is blown out

Vehicles for Australia (With an automatic transmission) and vehicles for Hong Kong built from July 1991

Vacuum	Normal condition
40 mmHg (1.57 in.Hg) or less	Air is not blown out
220 mmHg (8.66 in.Hg) or more	Air is blown out

Caution

When mounting the EGR valve, use a new gasket and tighten to a torque of 19–28 Nm (1.9–2.8 kgm, 14–20 ft.lbs.)

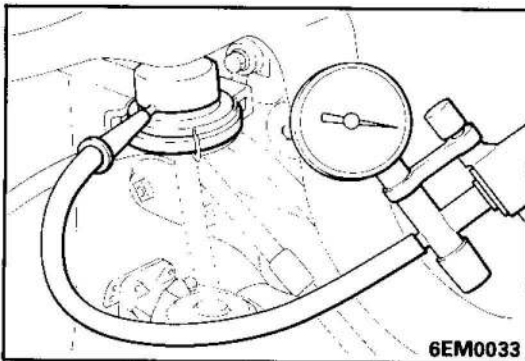

6EM0033

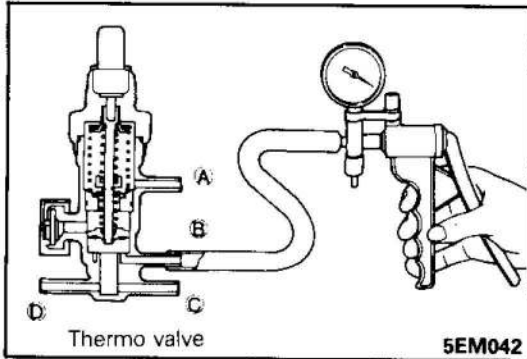

Thermo valve

5EM042

4. CHECKING OF VACUUM REGULATOR VALVE (VRV) (Vehicles for Australia and vehicles for Hong Kong built from July 1991)

- (1) Disconnect the vacuum hose (white stripes) from the vacuum regulator valve (VRV) and connect the hand vacuum pump to the VRV.
- (2) Apply a vacuum of 400 mmHg (15.7 in.Hg) to the VRV and inspect.

Engine status	Normal condition
Stop	Vacuum leaks
3,500 r/min.	Vacuum is maintained

5. CHECKING OF THERMO VALVE (excluding Vehicles for General Export)

- (1) Disconnect the vacuum hose (green stripes) from the thermo valve and connect the hand vacuum pump to the thermo valve.
- (2) Apply vacuum to check the thermo valve.

Engine coolant temperature	Normal condition
40°C (104°F) or less	Vacuum leaks
80°C (176°F) or more	Vacuum is maintained

Caution

1. Do not apply spanners, etc., to the plastic parts of the thermo valve.
2. When installing, coat threads with a sealant (3M NUT Locking Part No. 4171 or equivalent) and tighten to a torque of 20–40 Nm (2–4 kgm, 14.5–28.9 ft.lbs.).

6. CHECKING OF SECONDARY AIR CONTROL VALVE (Vehicles with 4G32 or 4G63 engine for Europe and vehicles for Australia and vehicles for Hong Kong built from July 1991)

- (1) Remove the secondary air control valve
- (2) Blow air from the air cleaner side and make sure that the air does not pass through.

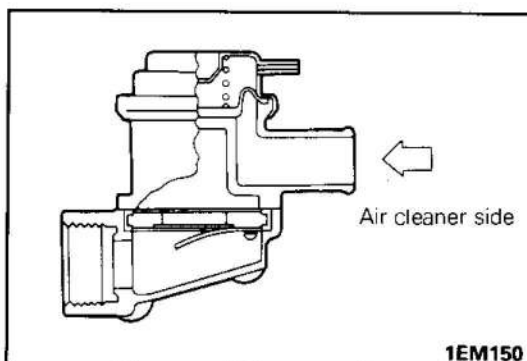

1EM150

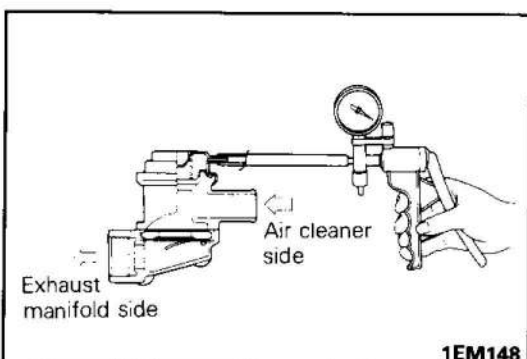

1EM148

- (3) Connect a hand vacuum pump to the nipple of the secondary air control valve.
- (4) Apply a vacuum of 500 mmHg (19.7 in.Hg) and check that airtightness is maintained.

(5) Apply a vacuum of 170 mmHg (6.7 in.Hg) and check whether or not air passes through.

Direction of air	Normal condition
Air cleaner side → exhaust manifold side	Air passes through
Exhaust manifold side → air cleaner side	Air does not pass through

(6) If inspection reveals any additional problems, replace the secondary air control valve.

7. CHECKING OF INTAKE AIR TEMPERATURE CONTROL DEVICES (Vehicles for Europe, cold climate specification of General Export and vehicles for Australia and vehicles for Hong Kong built from July 1991)

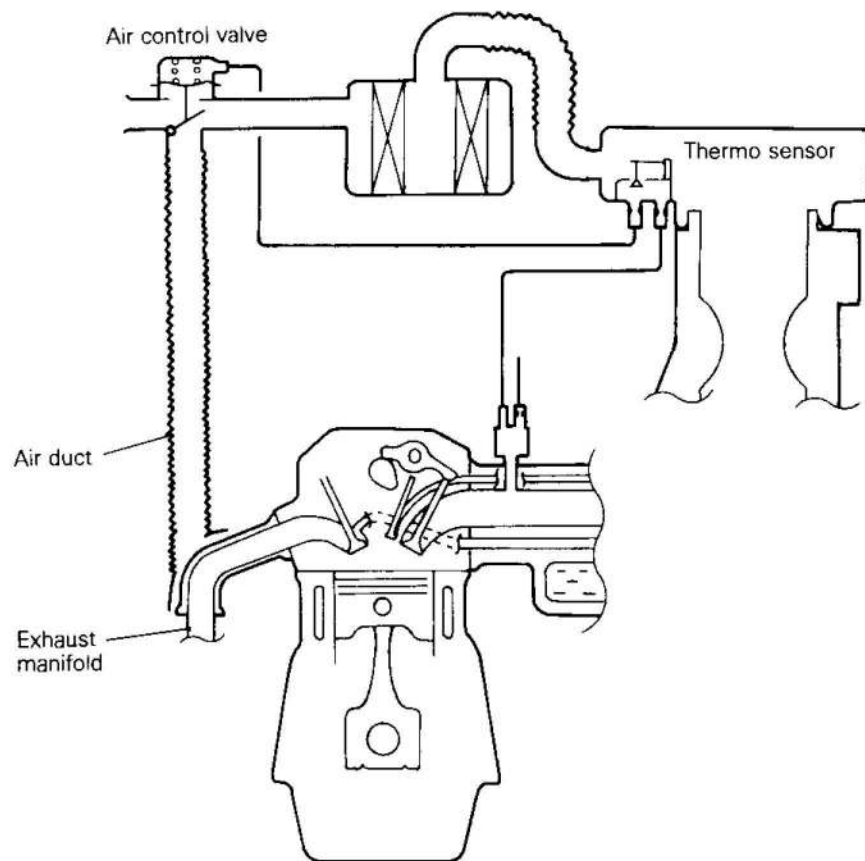

03G0035

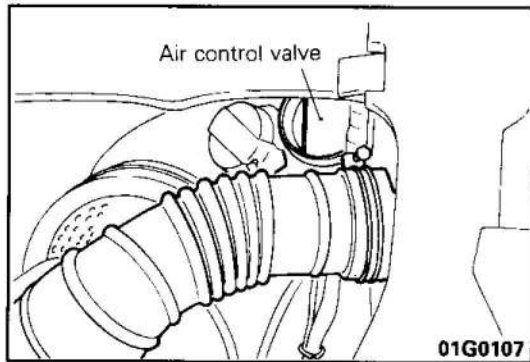

- (1) Remove the air cleaner cover assembly and air duct.
- (2) Idle the engine and inspect the opening and closing of the air control valve.

Thermo sensor temperature	Normal condition
30°C (86°F) or less	The cool air port side closes
45°C (113°F) or higher	The cool air port side opens

NOTE

If necessary, cool by blowing compressed air or warm using a hair dryer, etc.

- (3) Disconnect the intake manifold side vacuum hose from the thermo sensor, place a finger over the end of the hose and check for vacuum.

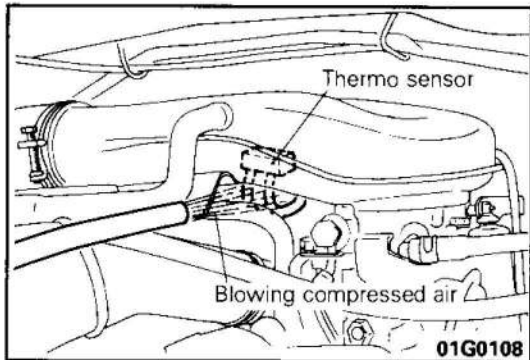

SERVICE ADJUSTMENT PROCEDURES (4G92, 4G63 engines) — Vehicles with conventional carburetor built from June 1994

VACUUM HOSE PIPING DIAGRAM

Vehicles for Europe (6B model) and General Export and Gulf countries

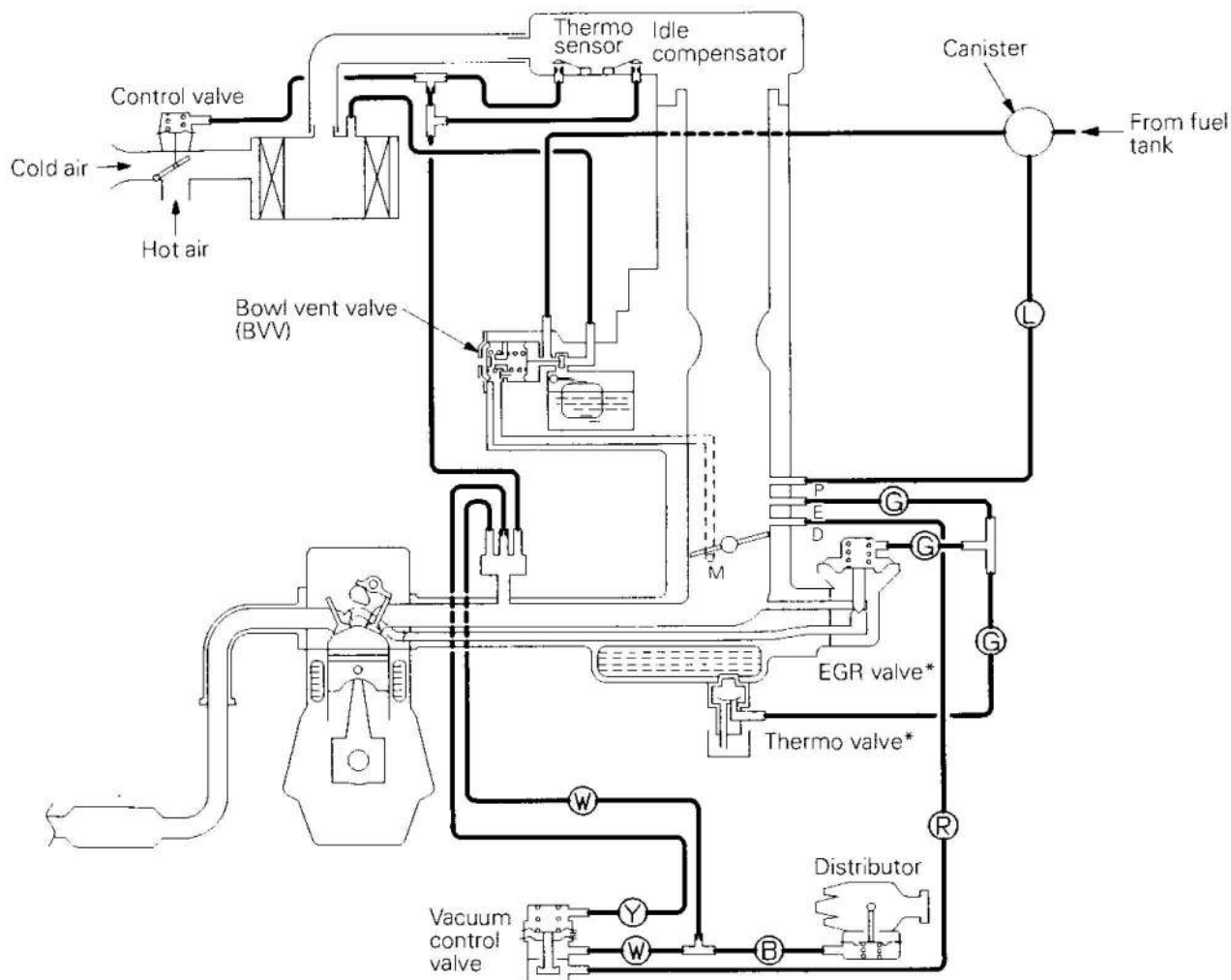

6FU2378

NOTE

*: Vehicles for Gulf countries

Vacuum hose colour

- B: Black
- G: Green
- L: Light blue
- R: Red
- W: White
- Y: Yellow

Vehicles for Columbia, Bolivia and Ecuador

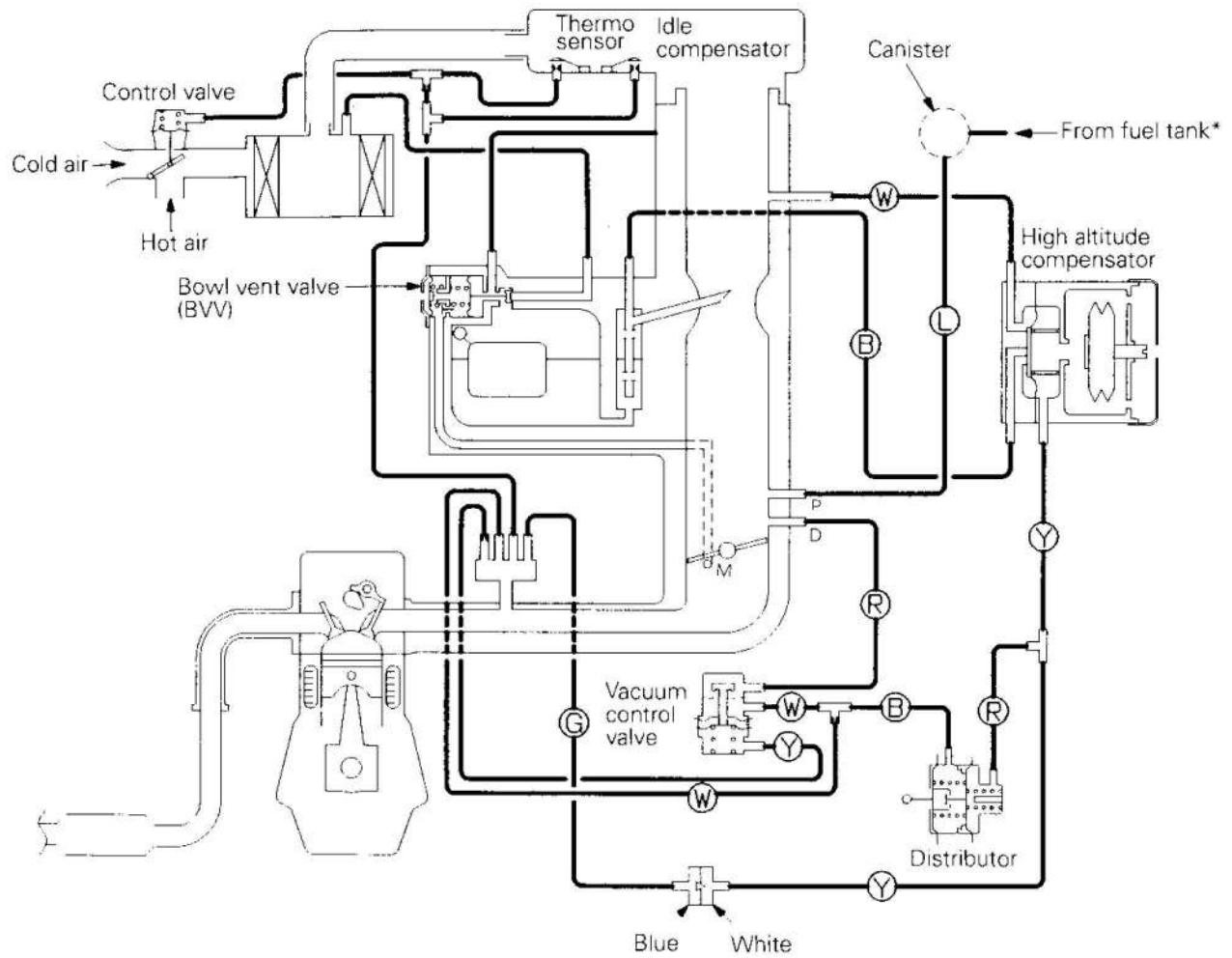

6FU2379

NOTE
*: Vehicles for Columbia

Vacuum hose colour
 B: Black
 G: Green
 L: Light blue
 R: Red
 W: White
 Y: Yellow

Vehicles for Australia

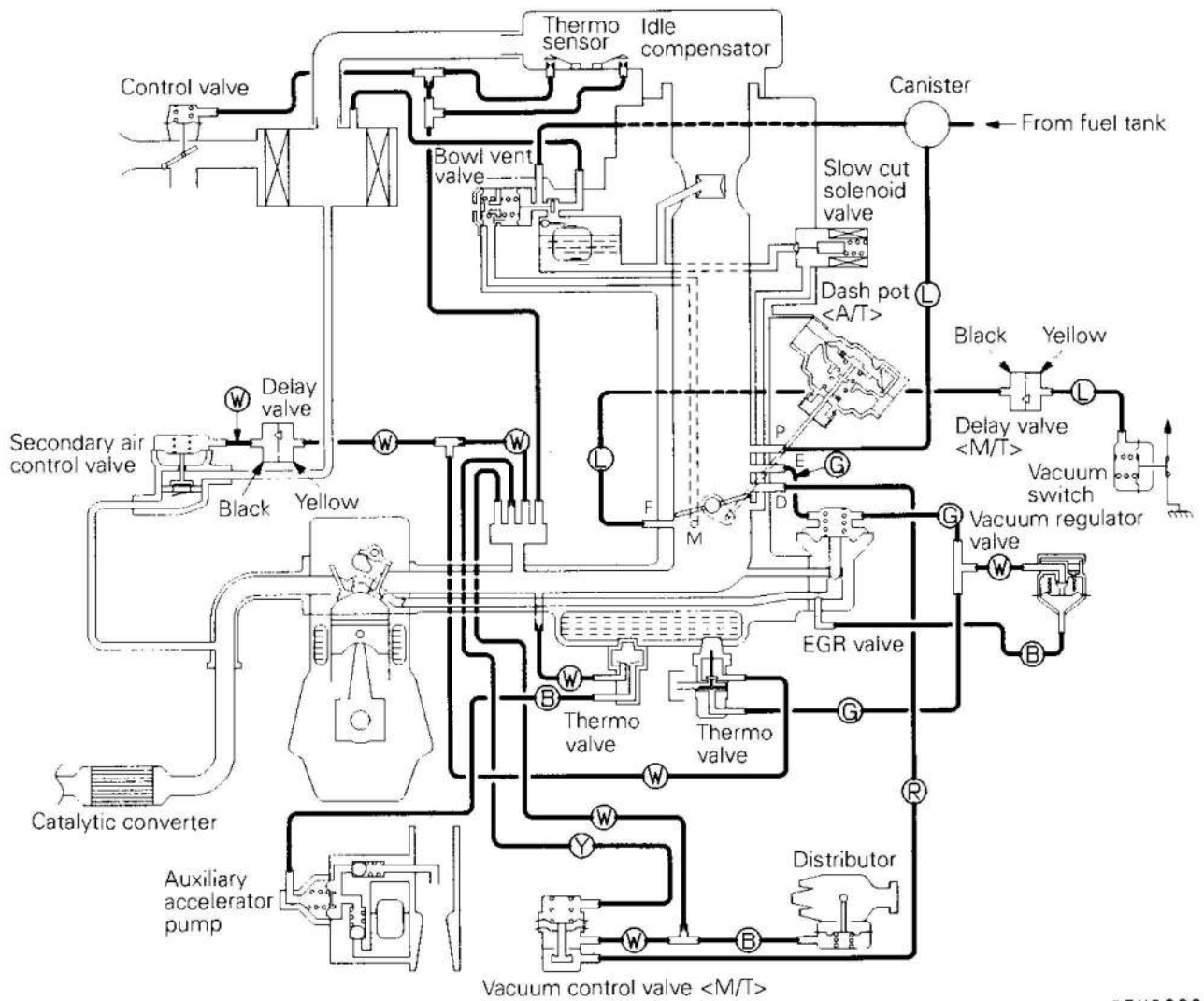

6FU2380

- Vacuum hose colour
- B: Black
 - G: Green
 - L: Light blue
 - R: Red
 - W: White
 - Y: Yellow

VACUUM HOSE LAYOUT

Vehicles for Europe (6B model) and General Export and Gulf Countries

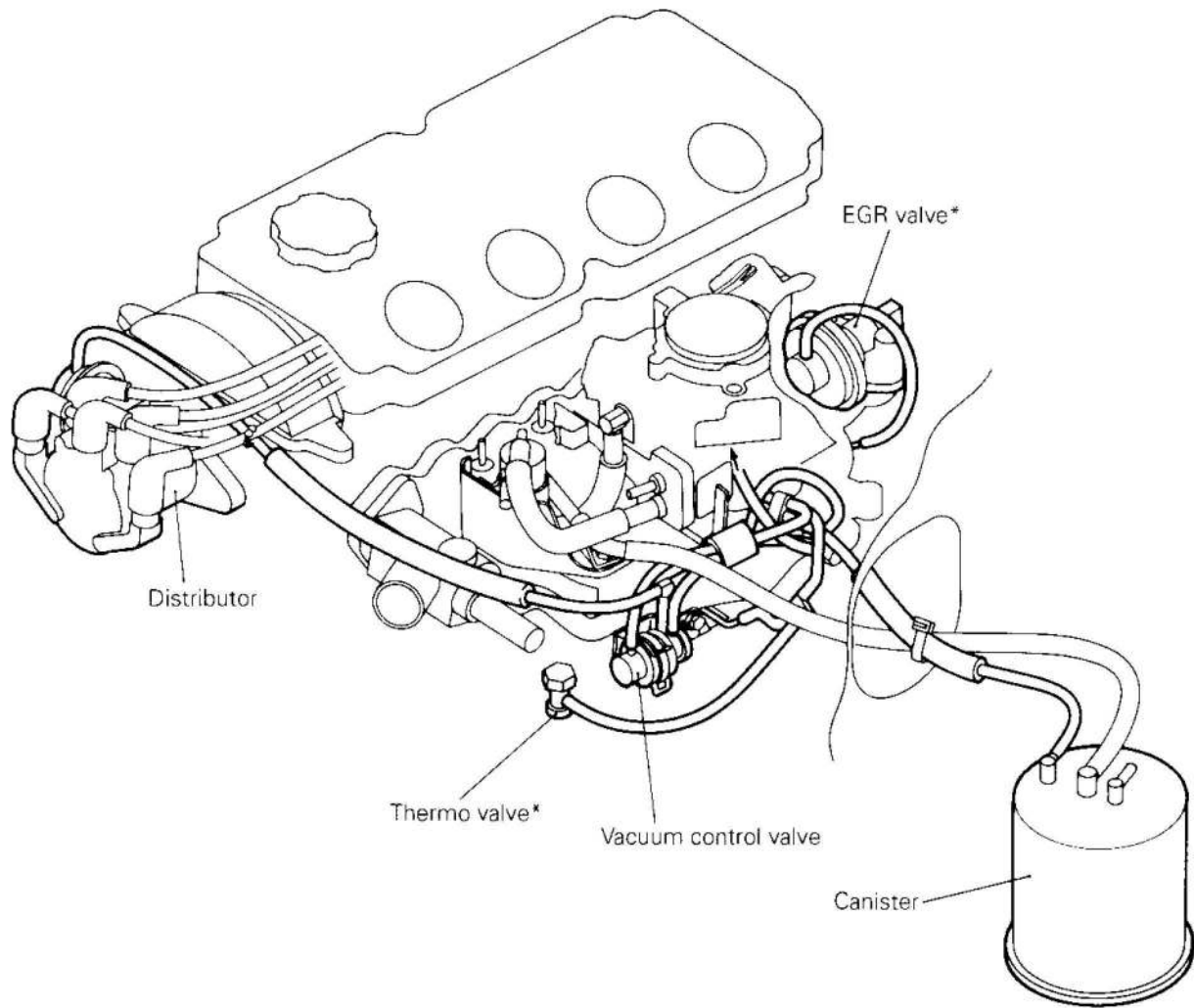

6FU2381

NOTE
*: Vehicles for Gulf Countries

Vehicles for Columbia, Bolivia and Ecuador

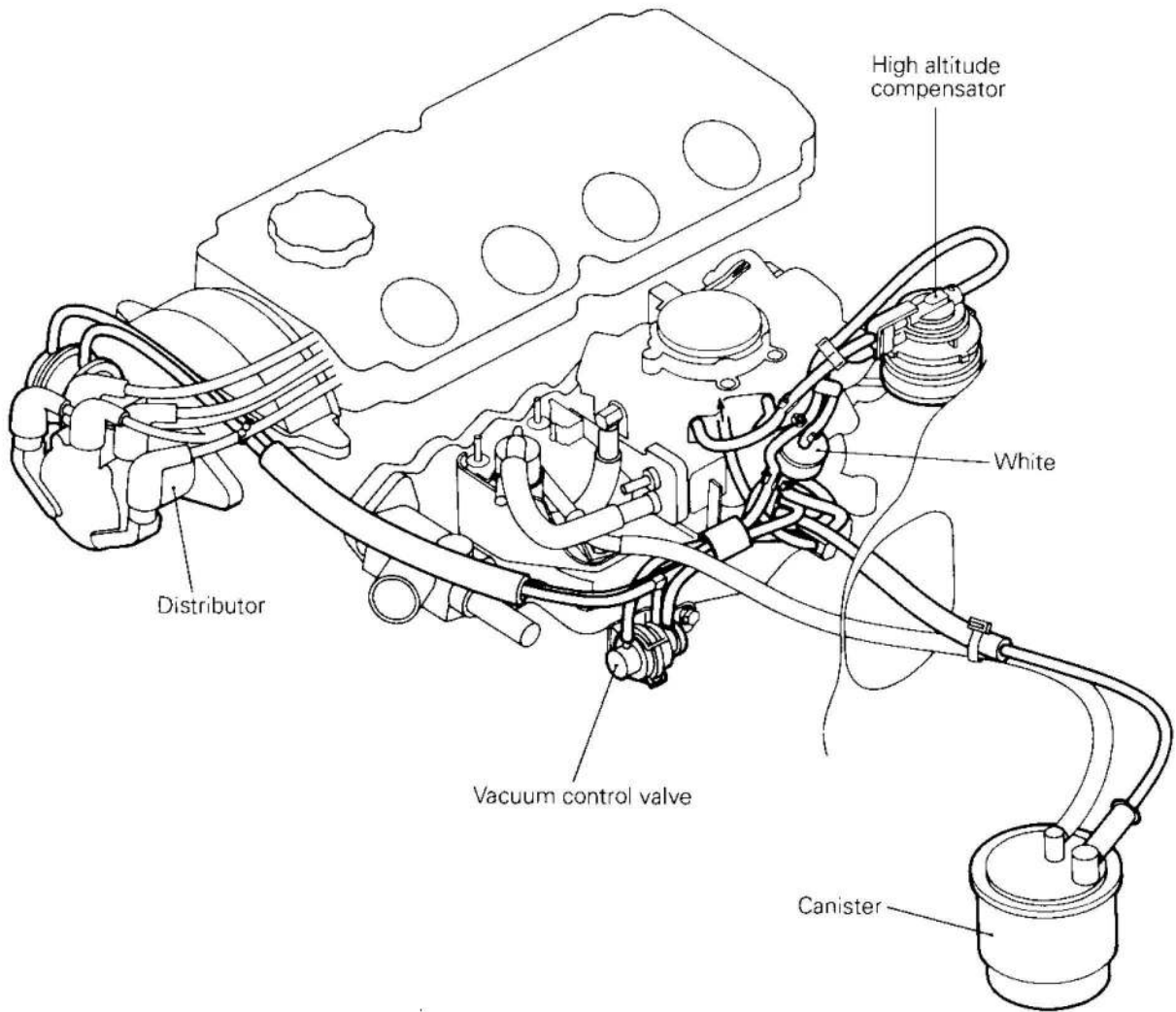

6FU2382

Vehicles for Australia

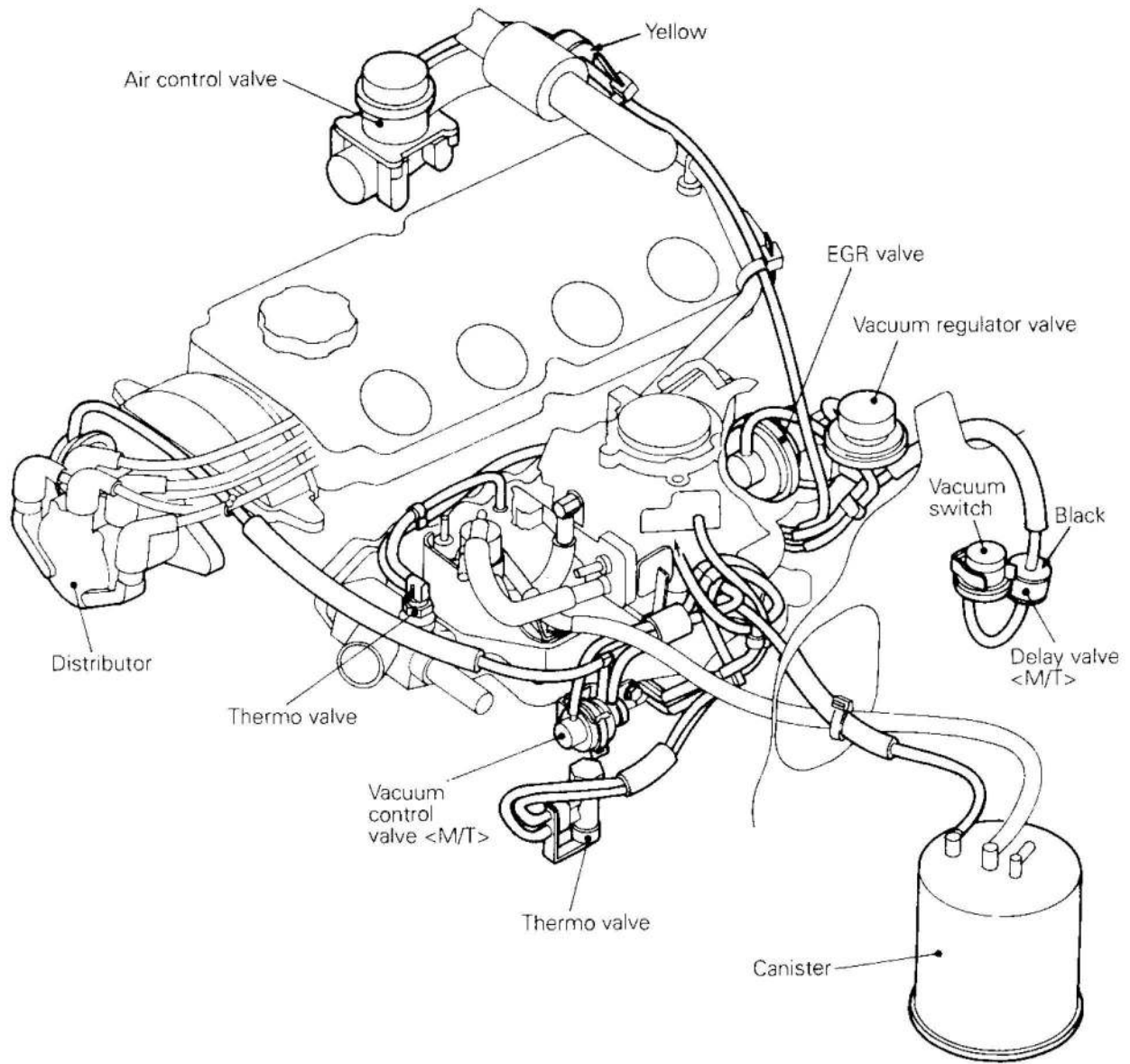

6FU2383

CAUTIONS ON INSPECTION

E17FFAA0

- (1) Inspect the various devices only after completing engine adjustment.
- (2) Inspect the hoses to make sure there are no disconnections, connection errors or damage.
- (3) Make sure there is no hose, pipe or port clogging, or cracks or damage in the hoses and pipes.
- (4) When replacing device hoses, always mount the replacement hose in the same position (direction) as the original.
- (5) When finished, check the connections as described in the service manual.

CRANKCASE EMISSION CONTROL SYSTEM**1. INSPECTION OF POSITIVE CRANKCASE VENTILATION SYSTEM**

- (1) Remove the ventilation hose from the positive crankcase ventilation valve.
- (2) Remove the positive crankcase ventilation valve from the rocker cover.
- (3) Reinstall the positive crankcase ventilation valve at the ventilation hose.
- (4) Start the engine and run at idle.

- (5) Place a finger at the opening of the positive crankcase ventilation valve and confirm that vacuum of the intake manifold is felt.

NOTE

At this moment, the plunger in the positive crankcase ventilation valve moves forward and backward.

- (6) If vacuum is not felt, clean the positive crankcase ventilation valve or replace it.

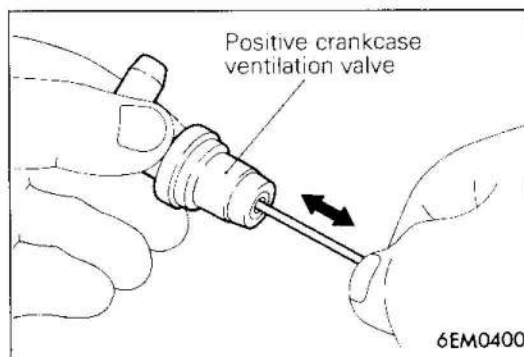
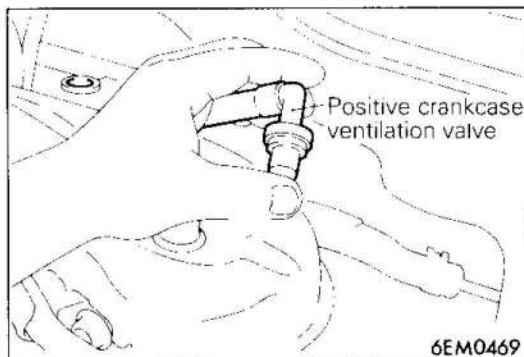
**2. CHECKING OF POSITIVE CRANKCASE VENTILATION (PCV) VALVE**

- (1) Insert a thin rod into the positive crankcase ventilation valve from the side shown in the illustration (rocker cover installation side), and move the rod back and forth to confirm that the plunger moves.
- (2) If the plunger does not move, there is a clogging in the positive crankcase ventilation valve. In this case, clean or replace the valve.

EVAPORATIVE EMISSION CONTROL SYSTEM**1. CHECKING OF BOWL VENT VALVE (BVV)**

Refer to P.17-17.

EXHAUST EMISSION CONTROL SYSTEM**1. CHECKING OF EGR SYSTEM (Vehicles for Gulf Countries)**

Refer to P.17-17.

2. CHECKING OF EGR SYSTEM (Vehicles for Australia)

Refer to P.17-18.

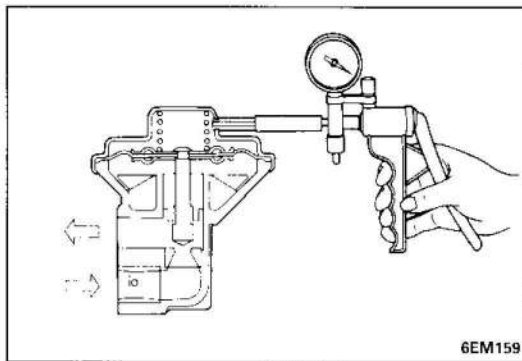

3. CHECKING OF EGR VALVE (Vehicles for Gulf countries and Australia)

- (1) Remove the EGR valve and inspect for sticking, carbon deposits, etc. If found, clean with a suitable solvent so that the valve seats correctly.
- (2) Connect a hand vacuum pump to the EGR valve.
- (3) Apply a vacuum of 500 mmHg (19.7 in.Hg) and make sure that airtightness is maintained. Check whether or not air is blown out of the EGR air passage.

Vehicles for Gulf Countries

Vacuum	Normal condition
40 mmHg (1.57 in.Hg) or less	Air is not blown out
120 mmHg (4.72 in.Hg) or more	Air is blown out

Vehicles for Australia (With a manual transmission)

Vacuum	Normal condition
50 mmHg (1.97 in.Hg) or less	Air is not blown out
190 mmHg (7.48 in.Hg) or more	Air is blown out

Vehicles for Australia (With an automatic transmission)

Vacuum	Normal condition
50 mmHg (1.97 in.Hg) or less	Air is not blown out
220 mmHg (8.66 in.Hg) or more	Air is blown out

Caution

When mounting the EGR valve, use a new gasket and tighten to a torque of 17–26 Nm (1, 7–2, 6 kgm, 12–19 ft.lbs.)

4. CHECKING OF THERMO VALVE (Vehicles for Gulf Countries)

Caution

When removing and installing, do not apply the spanner to the resin section of the thermo valve.

- (1) Connect a hand vacuum pump to the thermo valve nipple, and check the airtightness when a vacuum is applied.

Engine coolant temperature	Normal state
40°C (104°F) or less	Vacuum leaks
80°C (176°F) or more	Vacuum is maintained

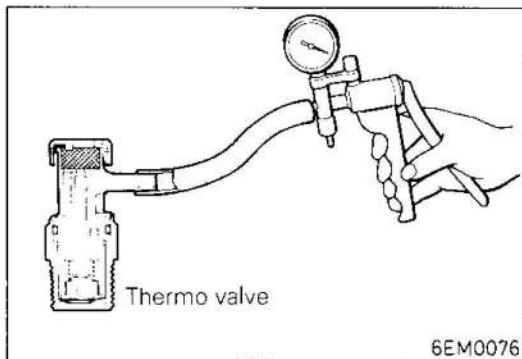

- (2) After applying specified sealant to the thread section, tighten to the specified torque.

Specified sealant: 3M NUT Locking No. 4171 or equivalent

Specified torque: 20–50 Nm (2–5 kgm, 15–36 ft.lbs.)

5. CHECKING OF THERMO VALVE (Vehicles for Australia)

Caution

1. When removing and installing, do not apply the spanner to the resin section of the thermo valve.
2. When disconnecting the vacuum hose, always make a mark so that the hose can be reconnected at its original position.

- (1) Disconnect all vacuum hoses connected to the thermo valve.

- (2) Connect a hand vacuum pump to each of the nipples, apply a vacuum and check whether or not air passes through the thermo valve.

Caution

Plug all nipples except the one to which the vacuum pump is connected.

Nipple B

Engine coolant temperature	Normal condition
40°C (104°F) or less	Vacuum leaks
80°C (176°F) or more	Vacuum is maintained

Nipple A

Engine coolant temperature	Normal condition
10°C (50°F) or less	Vacuum leaks
30°C (86°F) or more	Vacuum is maintained

- (3) After applying specified sealant to the thread section, tighten to the specified torque.

Specified sealant: 3M NUT Locking No. 4171 or equivalent

Specified torque: 20–40 Nm (2–4 kgm, 15–29 ft.lbs.)

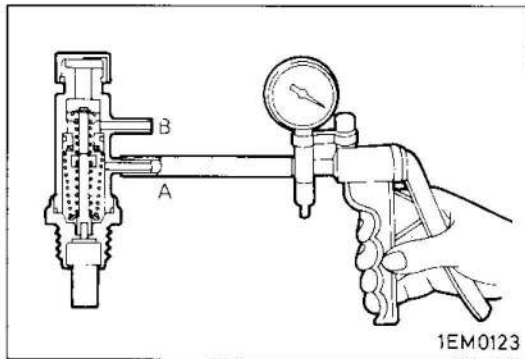

1EM0123

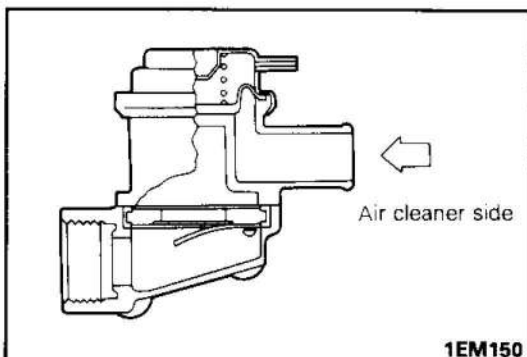

1EM150

6. CHECKING OF VACUUM REGULATOR VALVE (VRV) (Vehicles for Australia)

Refer to P.17-20.

7. CHECKING OF SECONDARY AIR CONTROL VALVE (Vehicles for Australia)

- (1) Remove the secondary air control valve
- (2) Blow air from the air cleaner side and make sure that the air does not pass through.

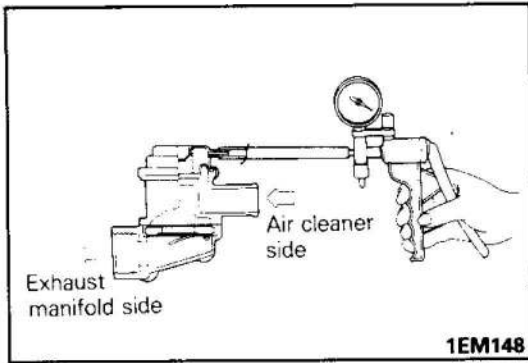

- (3) Connect a hand vacuum pump to the nipple of the secondary air control valve.
- (4) Apply a vacuum of 500 mmHg (19.7 in.Hg) and check that airtightness is maintained.
- (5) Apply a vacuum of 250 mmHg (9.8 in.Hg) and check whether or not air passes through.

Direction of air	Normal state
Air cleaner side → exhaust manifold side	Air passes through
Exhaust manifold side → air cleaner side	Air does not pass through

- (6) If inspection reveals any additional problems, replace the secondary air control valve.

8. CHECKING OF INTAKE AIR TEMPERATURE CONTROL DEVICES

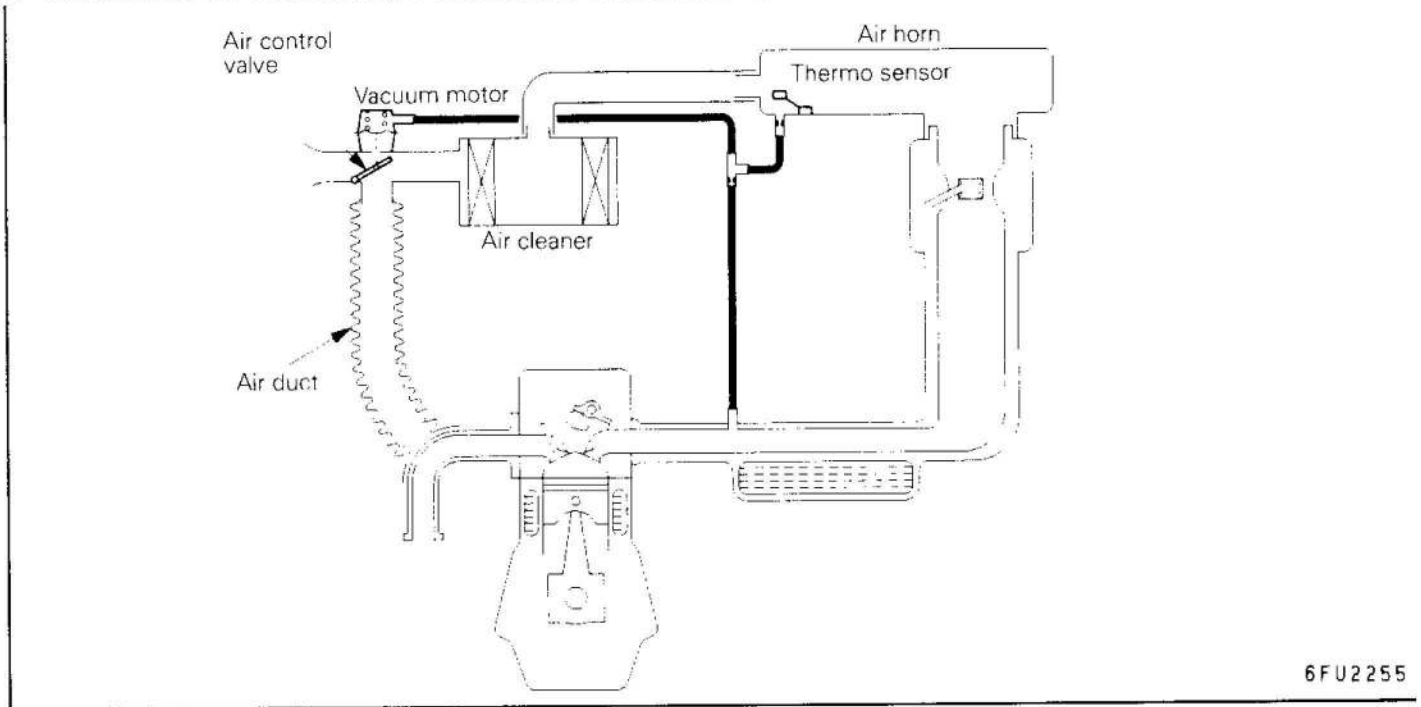

Refer to P.17-21 for the inspection procedure.

9. DECELERATION SPARK ADVANCE CONTROL <Except vehicles with automatic transmission for Australia>

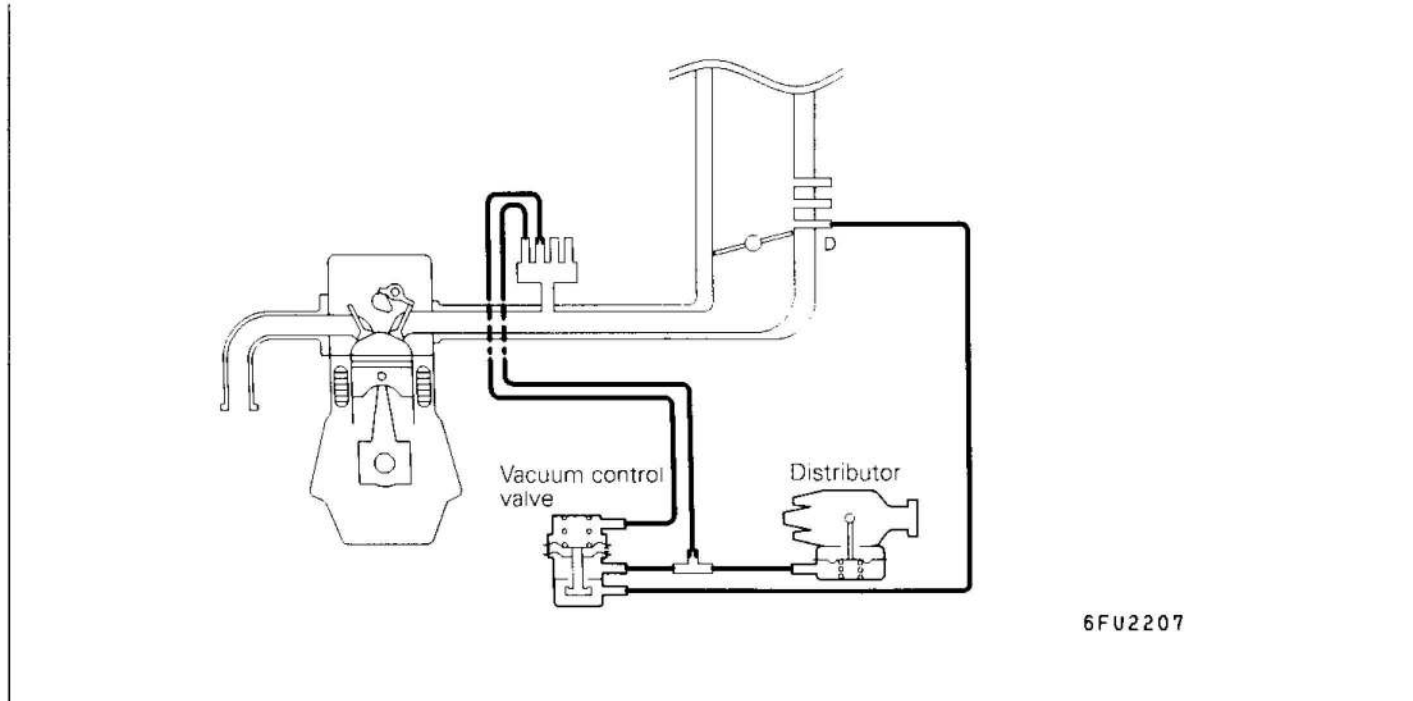

6FU2207

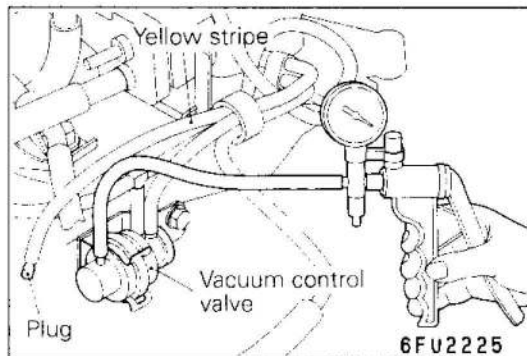

Deceleration spark advance control inspection

- (1) Connect a timing light.
- (2) Disconnect the vacuum hose (yellow stripe) from the vacuum control valve, and then connect a hand vacuum pump to the vacuum control valve.
- (3) Plug the end of the vacuum hose (yellow stripe) which was disconnected.
- (4) Start the engine and run it at idle.
- (5) Check that the ignition timing advances (approximately 20°) when 600 mmHg (24 in.Hg.) of negative pressure or more is applied.

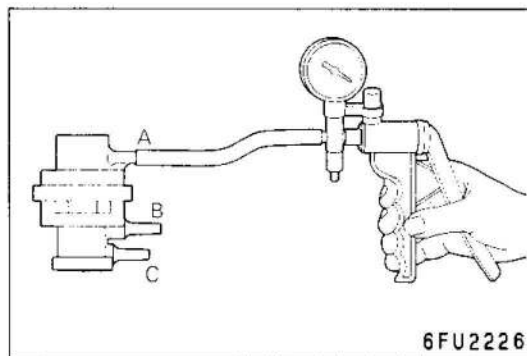

Inspection of vacuum control valve

- (1) Connect a hand vacuum pump to nipple A of the vacuum control valve.
- (2) Apply 675 mmHg (27 in.Hg.) of negative pressure, and check that the negative pressure is maintained.
- (3) Apply negative pressure and check whether air flows between nipple B and nipple C.

Vacuum	Passage of air
0	Yes
600 mmHg (24 in.Hg)	No

10. CHECKING OF HIGH ALTITUDE COMPENSATION SYSTEM

NOTE

- The range between altitudes of 1,500 m (4,921 ft.) and 2,500 m (8,202 ft.) is the range where the high altitude compensator (HAC) switches from operating to not operating. Thus the operation in this range of altitude will be unstable.
Accordingly, do not check the operation of the HAC within this range of altitude. Move the vehicle to an altitude of either 1,500 m (4,921 ft.) or below, or to an altitude of 2,500 m (8,202 ft.) or above before checking.
- When disconnecting the vacuum hose, put a mark on the hose so that it may be reconnected at original position.

Inspection at altitude below approx. 1,500 m (4,921 ft.)

- Remove the air horn.
- Disconnect the vacuum hose (black) from the carburetor primary emulsion well bleed nipple and plug the nipple.
- Connect a hand vacuum pump to the vacuum hose and check that vacuum is held when applied while running the engine at idle.
- Connect the disconnected vacuum hose to original position.
- While running the engine at idle, disconnect the vacuum hose (yellow stripe) from the HAC and hold a finger at the hose end to check that vacuum is felt.
- Connect the disconnected vacuum hose to original position.
- Run the engine at approximately 3,000 r/min with no load, and check that the engine runs normally.

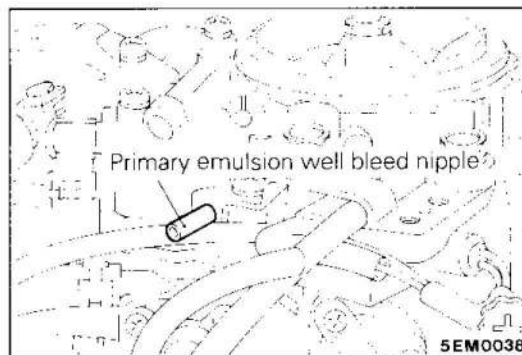
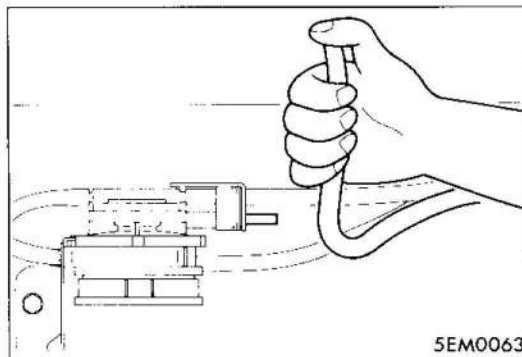
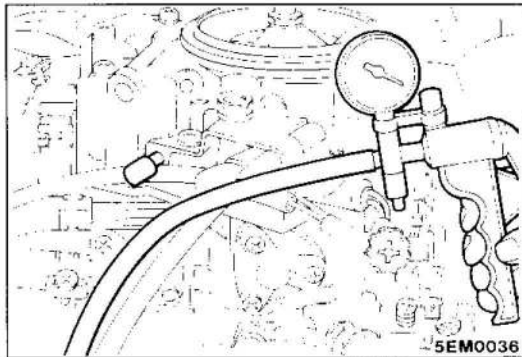
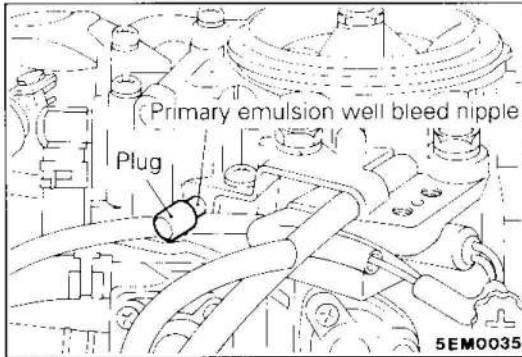

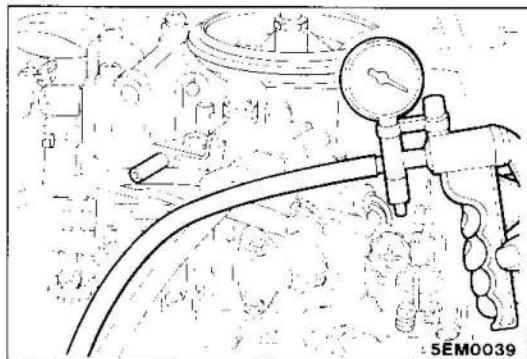

5EM0039

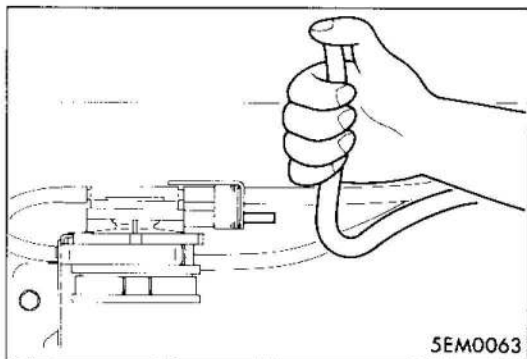

5EM0063

- (3) Connect a hand vacuum pump to the vacuum hoses and while running the engine at idle, apply vacuum from the vacuum pump to check that vacuum leaks and does not build up.
- (4) Connect the disconnected vacuum hose to original position.

- (5) While running the engine at idle, disconnection the vacuum hose (yellow stripe) from the HAC and hold a finger at the hose end to check that vacuum is felt.
- (6) Connect the disconnected vacuum hose to original position.
- (7) Run the engine at approximately 3,000 r/min with no load, and check that the engine runs normally with no black smoke being emitted.

11. CHECKING OF HIGH ALTITUDE COMPENSATOR

NOTE

1. The range between altitudes of 1,500 m (4,921 ft.) and 2,500 m (8,202 ft.) is the range where the high altitude compensator (HAC) switches from operating to not operating. Thus the operation in this range of altitude will be unstable.

Accordingly, do not check the operation of the HAC within this range of altitude. Move the vehicle to an altitude of either 1,500 m (4,921 ft.) or below, or to an altitude of 2,500 m (8,202 ft.) or above before checking.

2. When disconnecting the vacuum hose, put a mark on the hose so that it may be reconnected at original position.

Inspection at altitude below approx. 1,500 m (4,921 ft.)

- (1) Disconnect the vacuum hose (yellow stripe) from the HAC and connect a hand vacuum pump to the HAC nipple.
- (2) Apply vacuum and check that it leaks and does not hold.
- (3) Connect the disconnected vacuum hose to original position.

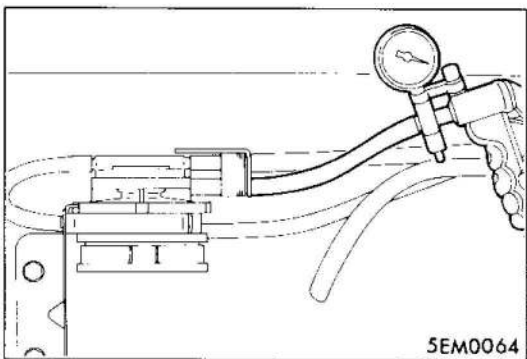

5EM0064

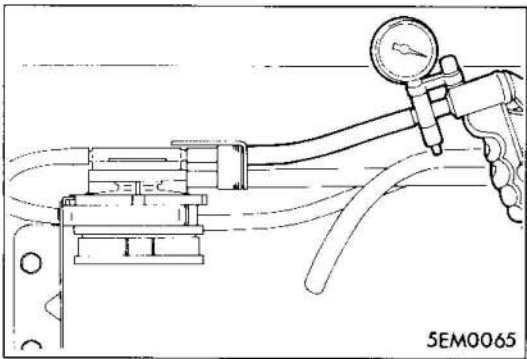

5EM0065

- (4) Disconnect the vacuum hose (black) from the HAC and connect a hand vacuum pump to the HAC nipple.
- (5) Check that vacuum holds when applied.
- (6) Connect the disconnected vacuum hose to original position.

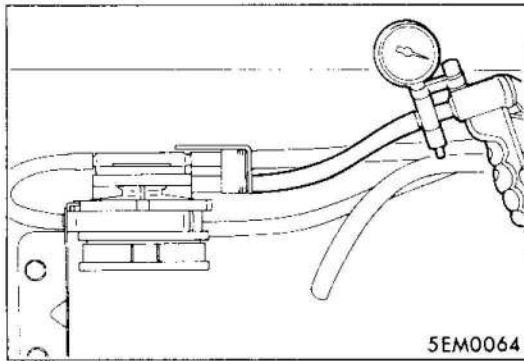

Inspection at altitude above approx. 2,500 m (8,202 ft.)

- (1) Disconnect the vacuum hose (yellow stripe) from the HAC and connect a hand vacuum pump to the HAC nipple.
- (2) Check that vacuum holds when applied.

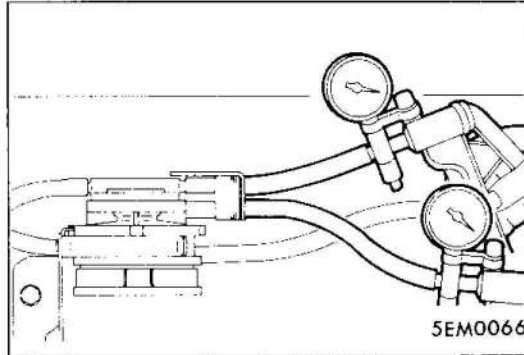

- (3) Disconnect the vacuum hose (black) from the HAC and connect another hand vacuum pump to the HAC nipple.
- (4) Holding the vacuum applied in procedure 2, apply vacuum and check that it leaks and does not hold.
- (5) Connect the disconnected vacuum hose to original position.

SERVICE ADJUSTMENT PROCEDURES (G63B engine) – Vehicles built up to May 1994

E17FE-1

EMISSION CONTROL DEVICES REFERENCE TABLE

Emission control system	Crankcase emission control system	Evaporative emission control system	Jet air system	Air fuel ratio control system	Three catalyst converter	Secondary air supply system	Exhaust gas recirculation (EGR) system	Intake air temperature control system	Deceleration	Reference page for each part inspection
Related parts	X									17-28
PCV valve		X								17-30
Bowl vent valve		X								17-29
Purge control valve		X					X			17-29
Thermo valve		X								-
Canister		X								-
Overflow limiter (2-way valve)		X								-
Jet valve			X							Engine (Group 11)
FBC system component				X		X				Fuel (Group 13)
Three catalyst converter					X					-
Secondary air control valve (with reed valve)						X				17-31
Secondary air control solenoid valve						X				17-32
EGR valve							X			17-34
Vacuum regulator valve							X			17-34
Check valve										-
Air control valve								X		17-35
Thermo sensor								X		17-35
Mixture control valve									X	17-34

VACUUM HOSE PIPING DIAGRAM

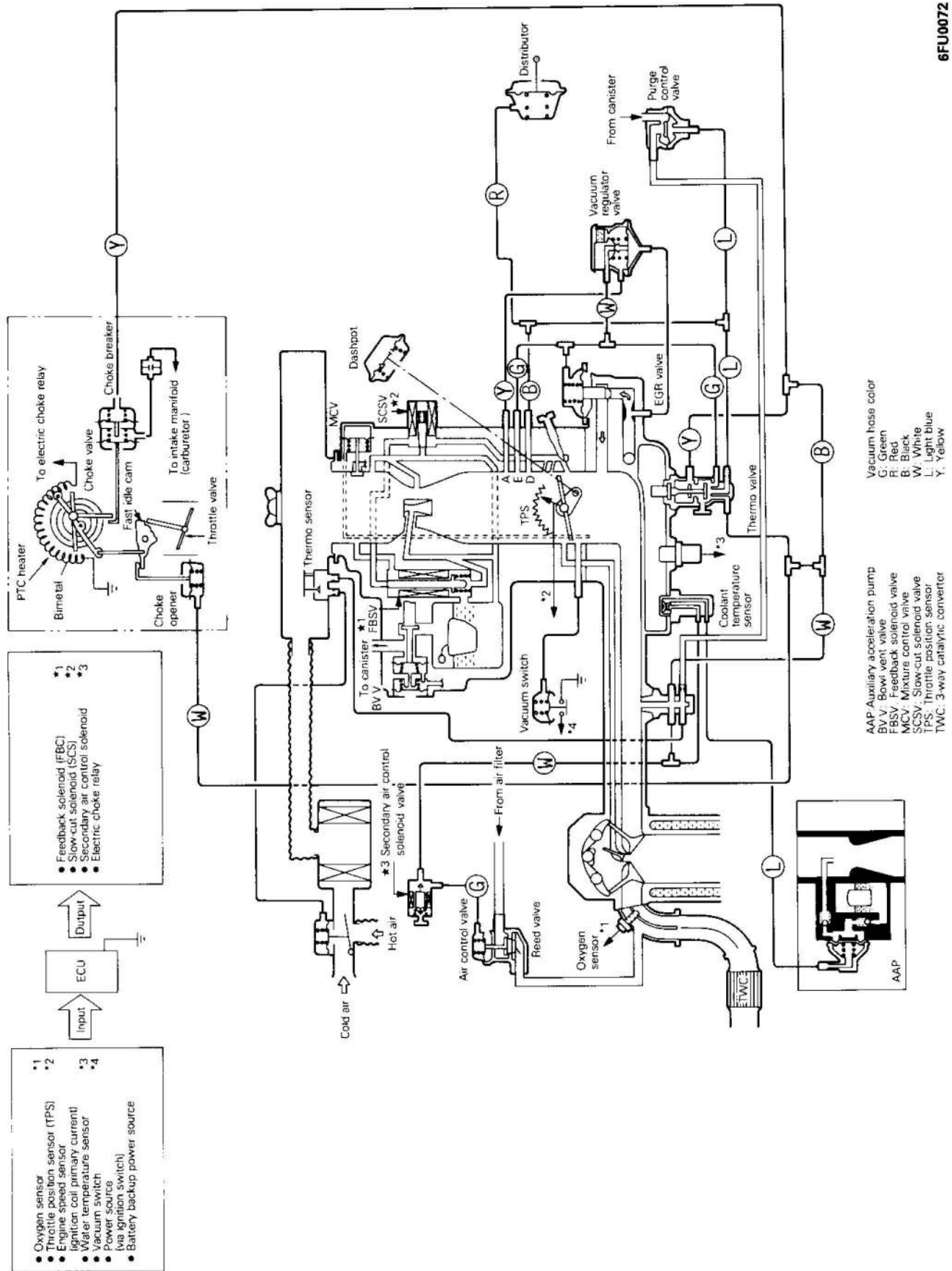

6FU0072

VACUUM HOSE LAYOUT

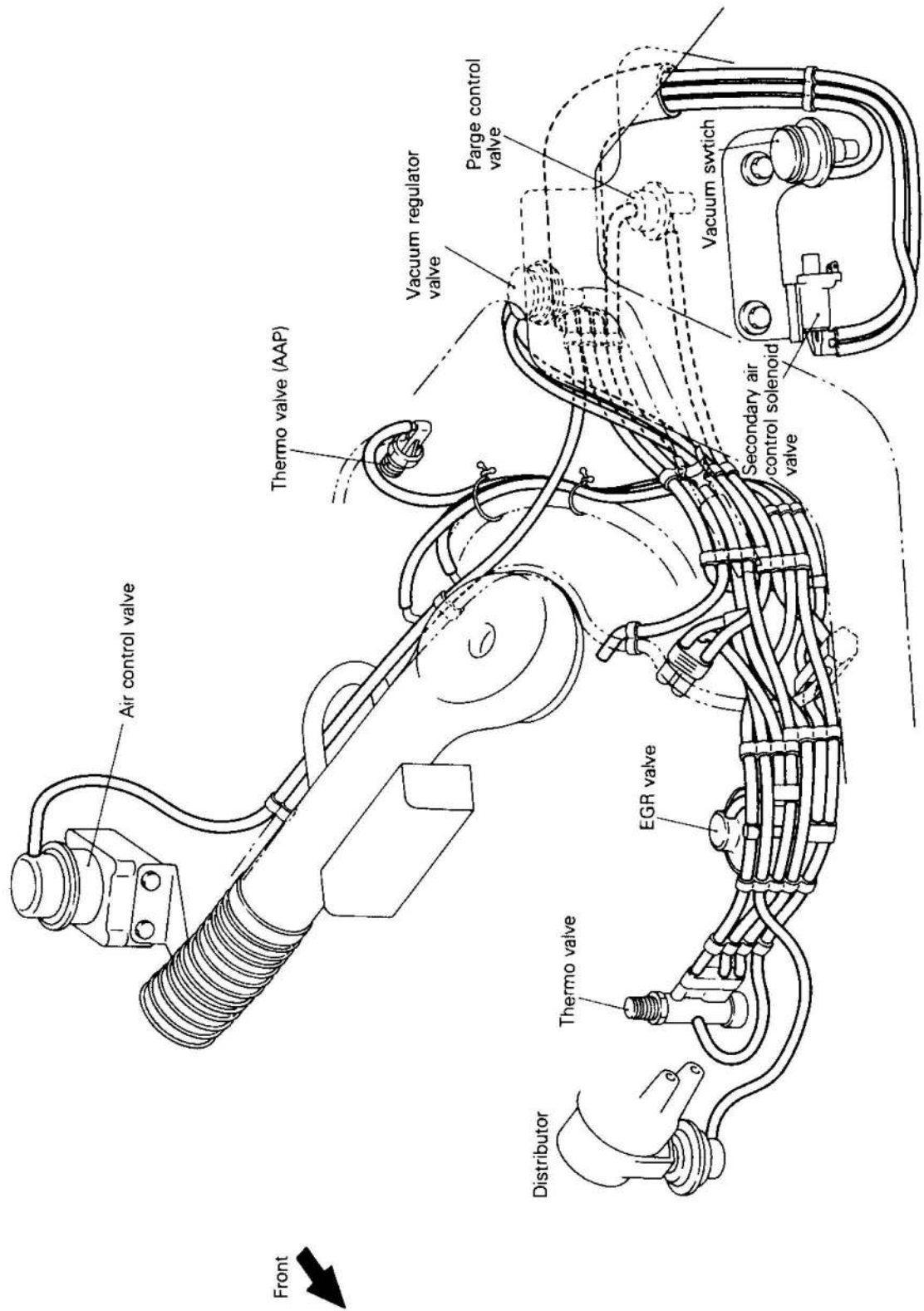

6FU0073

COMPONENT LAYOUT

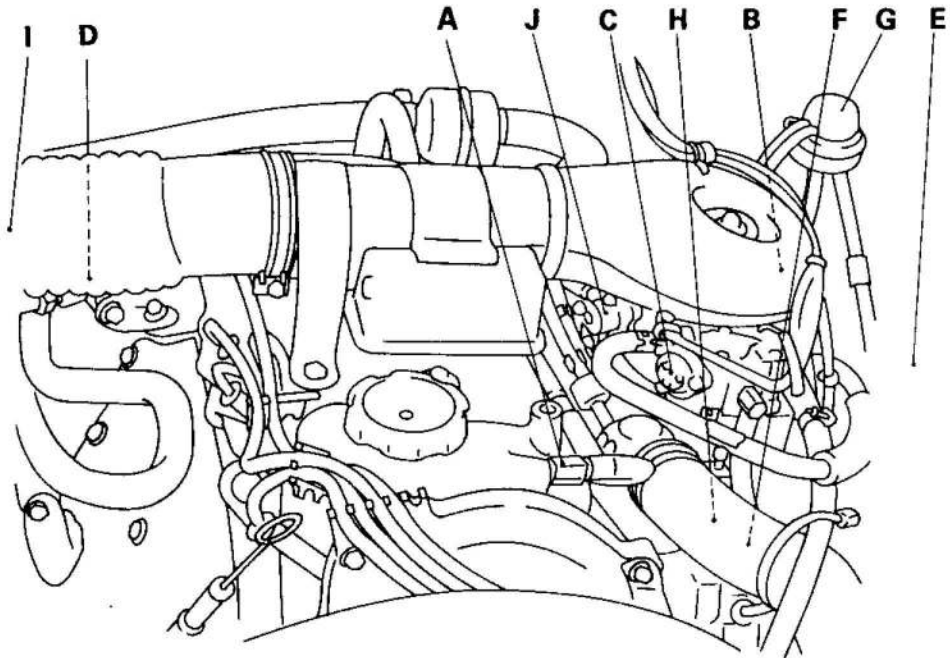

6EM0036

- A PCV valve
- B Canister
- C Bowl vent valve
- D Reed valve
- E Secondary air control solenoid valve
- F EGR valve
- G Vacuum regulator valve
- H Thermo valve
- I Air control valve
- J Mixture control valve

A PCV valve

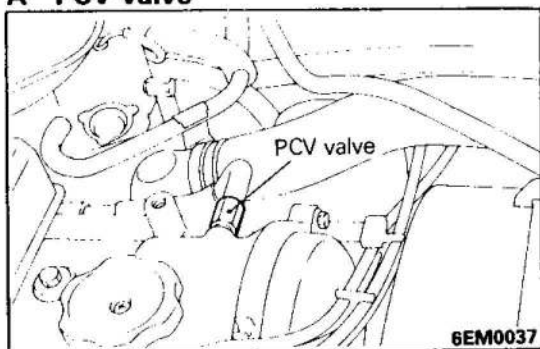

B Canister

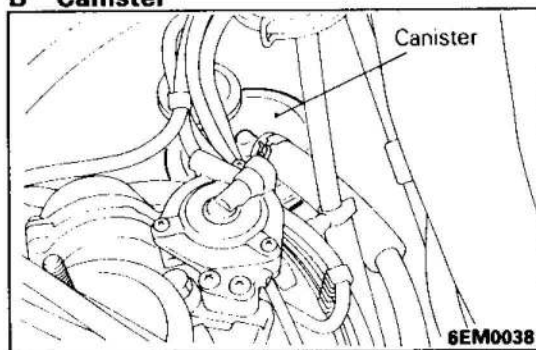

C Bowl vent valve

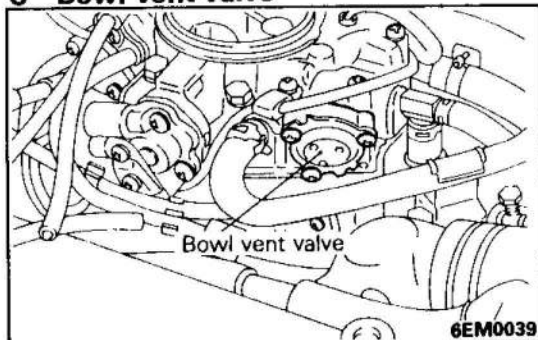

D Reed valve

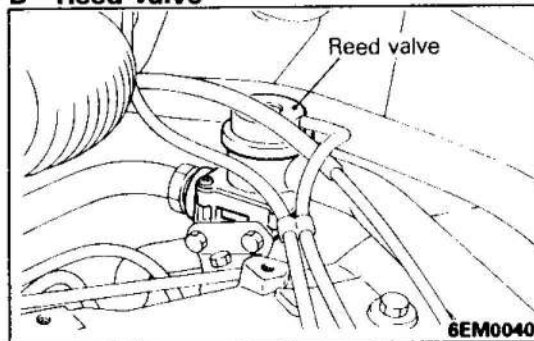

E Secondary air control solenoid valve

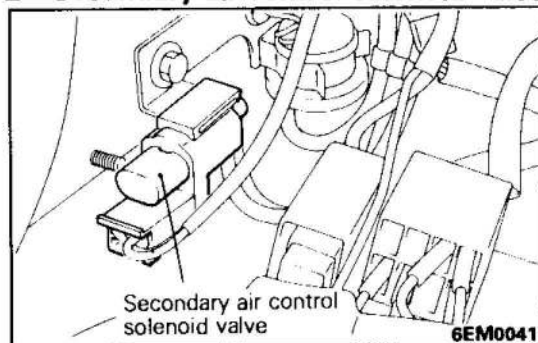

F EGR valve

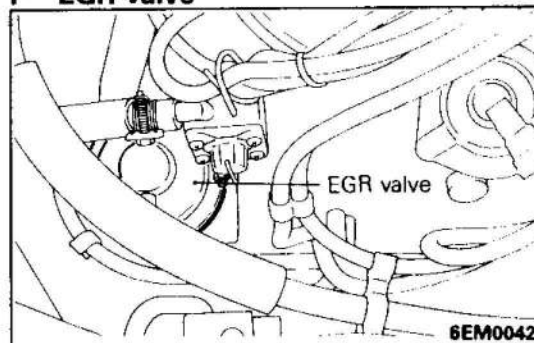

G Vacuum regulator valve

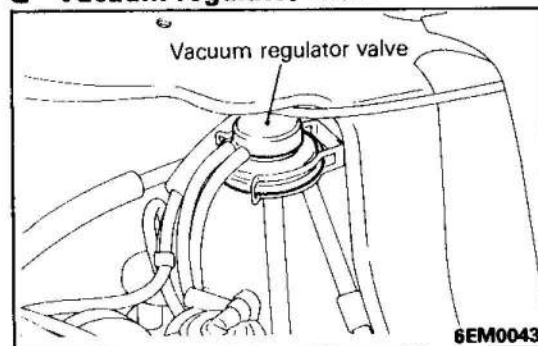

H Thermo valve

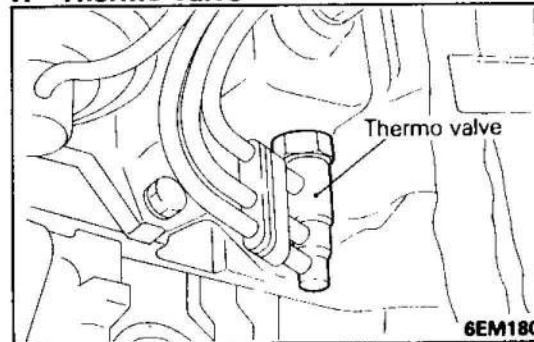

I Air control valve

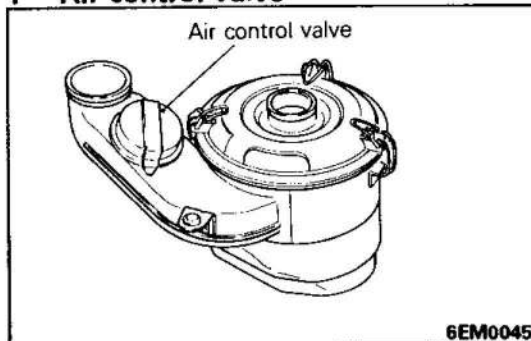

J Mixture control valve

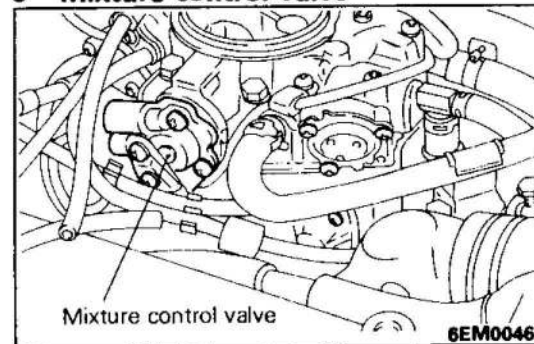

CAUTIONS ON INSPECTION

E17FFAA1

1. Inspect the various devices only after completing engine adjustment.
2. Inspect the hoses to make sure there are no disconnections, connection errors or damage.
3. Make sure there is no hose, pipe or port clogging, or cracks or damage in the hoses and pipes.
4. When replacing device hoses, always mount the replacement hose in the same position (direction) as the original.
5. When finished, check the connections as described in the service manual.

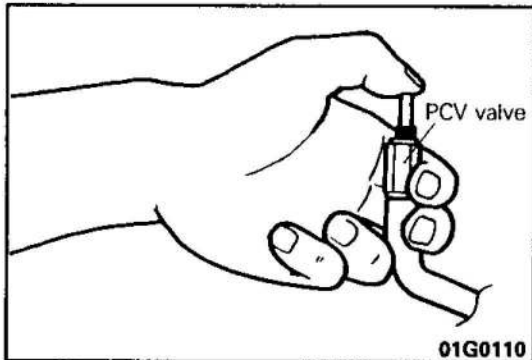
**CRANKCASE EMISSION CONTROL SYSTEM**

E17FAAB1

1. CHECKING OF PCV VALVE

- (1) After disconnecting the ventilation hose from the positive crankcase ventilation (PCV) valve, remove the PCV valve from the rocker cover and again connect the ventilation hose.
- (2) Run the engine at idling speed, place a finger over the end of the PCV valve opening and check the intake manifold vacuum.

NOTE

The plunger inside the PCV valve will move back and forth.

- (3) If vacuum cannot be felt against the finger, clean the PCV valve and ventilation hose with cleaning solvent, or else replace.

EVAPORATIVE EMISSION CONTROL SYSTEM

E17FBAD

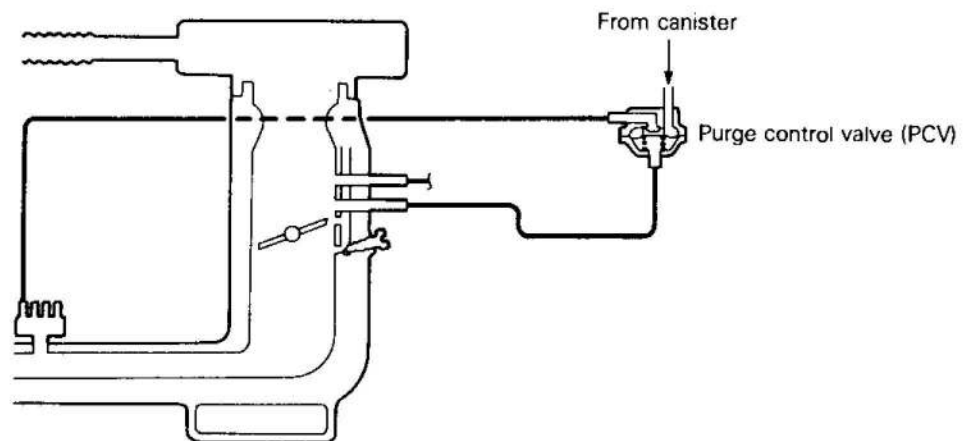
1. CHECKING OF PURGE CONTROL SYSTEM

6EM0025

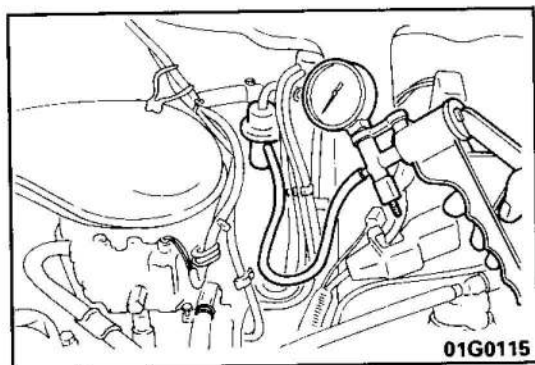

- (1) Disconnect the black vacuum hose from the intake manifold nipple and plug the nipple; then connect the disconnected black vacuum hose to a hand vacuum pump.
- (2) Inspect the following items with the engine cold [coolant temperature: 40°C (104°F) or less] and hot [coolant temperature: 80°C (176°F) or higher].

When engine is cold

Vacuum	Engine status	Normal condition
400 mmHg (15.7 in.Hg)	2,500 r/min.	Vacuum is maintained

When engine is hot

Vacuum	Engine status	Normal condition
400 mmHg (15.7 in.Hg)	Idling	Vacuum is maintained
400 mmHg (15.7 in.Hg)	2,500 r/min.	Vacuum leaks

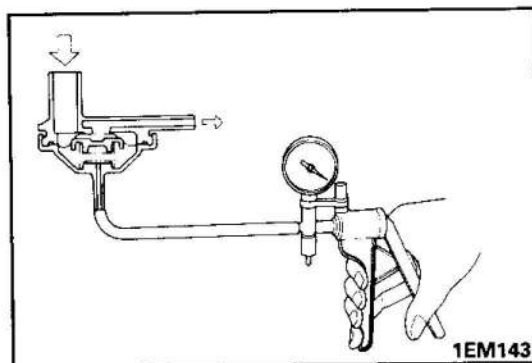

2. CHECKING OF PURGE CONTROL VALVE (PCV)

- (1) Remove the purge control valve.
- (2) Connect a hand vacuum pump to the nipple of the PCV.
- (3) Apply a vacuum of 400 mmHg (15.7 in.Hg) and make sure that airtightness is maintained.
- (4) Check whether or not air is lightly blown out from the nipple on the canister side.

Hand vacuum pump vacuum	Normal condition
0 mmHg (0 in.Hg) (no vacuum)	Air is not blown out
200 mmHg (7.9 in.Hg)	Air is blown out

3. CHECKING OF THERMO VALVE

NOTE

This thermo valve controls the choke breaker, EGR and choke opener.

Caution

1. Do not apply spanners, etc., to the plastic parts of the thermo valve.
2. When installing, coat threads with a sealant (3M NUT Locking Part No. 4171 or equivalent) and tighten to a torque of 20 – 40 Nm (2 – 4 kgm, 14.5 – 28.9 ft.lbs.).
3. When disconnecting the vacuum hose, always make a mark so that the hose can be reconnected at original position.

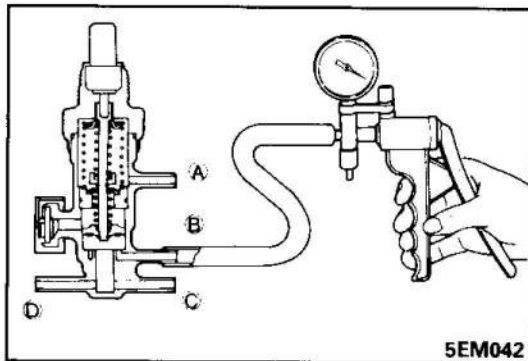

- (1) Disconnect all vacuum hoses connected to the thermo valve.
- (2) Connect a hand vacuum pump to each of the nipples, apply a vacuum and check whether or not air passes through the thermo valve.

Caution

Plug all nipples except the one to which the vacuum pump is connected.

Nipple B, C, D

Engine coolant temperature	Normal condition
50°C (122°F) or less	Vacuum leaks
80°C (176°F) or more	Vacuum is maintained

Nipple A

Engine coolant temperature	Normal condition
10°C (50°F) or less	Vacuum leaks
30°C (86°F) or more	Vacuum is maintained

4. CHECKING OF 2-WAY VALVE

Refer to GROUP 13 FUEL – Fuel Line.

5. CHECKING OF CANISTER

Refer to GROUP 13 FUEL – Fuel Line.

6. CHECKING OF BOWL VENT VALVE (BVV)**Caution**

Inspect after the engine has cooled. Fuel may be discharged from the BVV nipple if the engine is still warm.

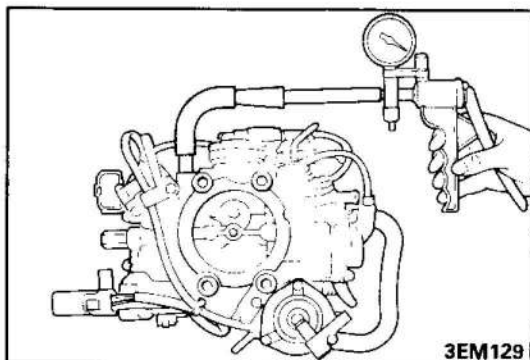

- (1) Remove the air horn.
- (2) Disconnect the bowl vapor hose from the bowl vent valve (BVV) nipple and connect a hand vacuum pump to the BVV nipple.
- (3) Apply a vacuum of 100 mmHg (3.94 in.Hg) to the BVV and inspect.

Engine status	Normal condition
Stop	Vacuum leaks
Idling	Vacuum is applied

EXHAUST EMISSION CONTROL SYSTEM

E17FCAF

1. CHECKING OF AIR-FUEL RATIO CONTROL SYSTEM (FBC)

Refer to GROUP 13 FUEL – Service Adjustment Procedures (FBC).

2. CHECKING OF ENGINE COOLANT TEMPERATURE SENSOR

Refer to GROUP 13 FUEL – Service Adjustment Procedures (FBC).

3. CHECKING OF ENGINE SPEED SENSOR

Refer to GROUP 13 FUEL – Service Adjustment Procedures (FBC).

4. CHECKING OF VACUUM SWITCH

Refer to GROUP 13 FUEL – Service Adjustment Procedures (FBC).

5. CHECKING OF SECONDARY AIR SUPPLY SYSTEM

(1) Disconnect the air supply hose from the air horn, place a small steel plate over the end of the hose and check the air intake.

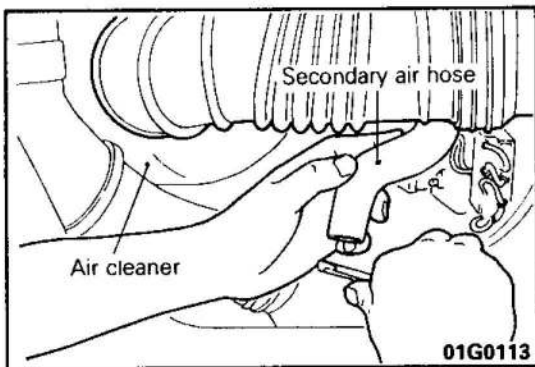

Coolant temperature	Engine status	Air intake
20–40°C (68–104°F)	Idling	Yes
70°C (158°F) or higher		Yes (within 70 sec. after starting the engine)
		No (70 sec. or more after starting the engine)
	Rapid deceleration from 4,000 r/min.	Yes

Caution

Note that exhaust blowback sometimes occurs if the secondary air control valve is faulty.

6. CHECKING OF SECONDARY AIR CONTROL VALVE

- (1) Remove the secondary air control valve.
- (2) Blow air from the air cleaner side and make sure that the air does not pass through.

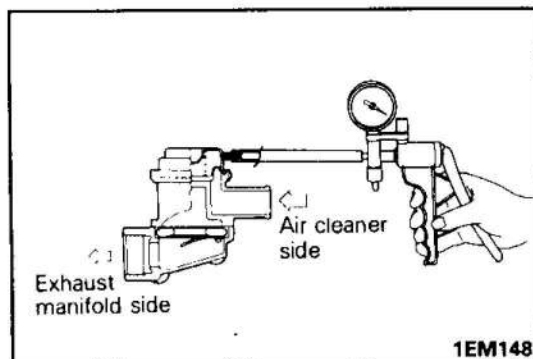
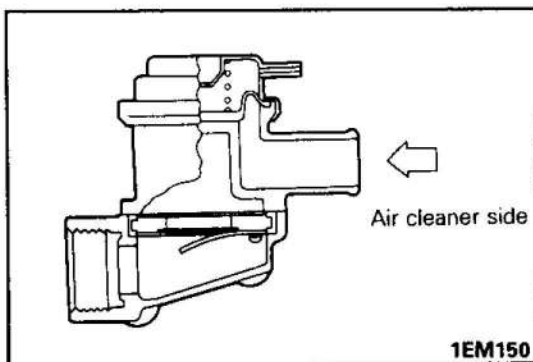

- (3) Connect a hand vacuum pump to the nipple of the secondary air control valve.
- (4) Apply a vacuum of 500 mmHg (19.7 in.Hg) and check that airtightness is maintained.

- (5) Apply a vacuum of 170 mmHg (6.7 in.Hg) and check whether or not air passes through.

Direction of air	Normal condition
Air cleaner side → exhaust manifold side	Air passes through
Exhaust manifold side → air cleaner side	Air does not pass through

- (6) If inspection reveals any additional problems, replace the secondary air control valve.

7. CHECKING OF SECONDARY AIR CONTROL SOLENOID VALVE

NOTE

when disconnecting the vacuum hose, always make a mark so that the hose can be reconnected at original position.

- (1) Disconnect the vacuum hose (white stripes, green stripes) from the solenoid valve.
- (2) Disconnect the harness connector.

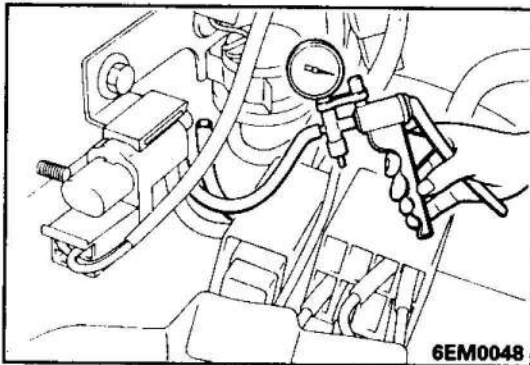

6EM0048

- (3) Connect a hand vacuum pump to the nipple to which the vacuum hose with white stripes was connected.

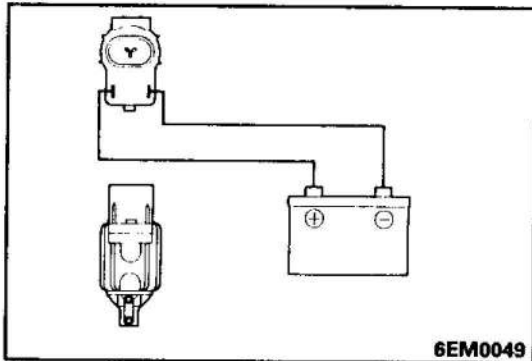

6EM0049

- (4) Check airtightness by applying a vacuum with voltage applied directly from the battery to the solenoid valve terminal and without applying voltage.

Battery voltage	Solenoid valve opposite nipple	Normal condition
Applied	Open	Vacuum leaks
	Blocked with finger	Vacuum maintained
Not applied	Open	Vacuum maintained

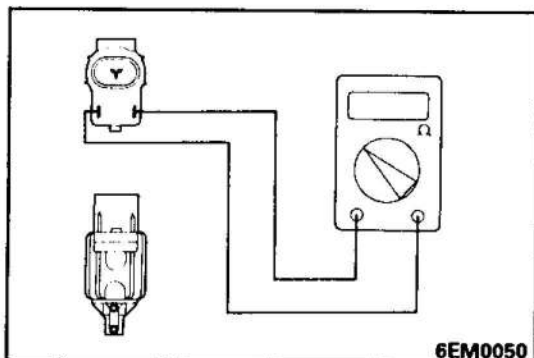

6EM0050

- (5) Measure the resistance of the solenoid valve.

Standard value: 38–44 Ω [at 20°C (68°F)]

8. CHECKING OF EGR SYSTEM

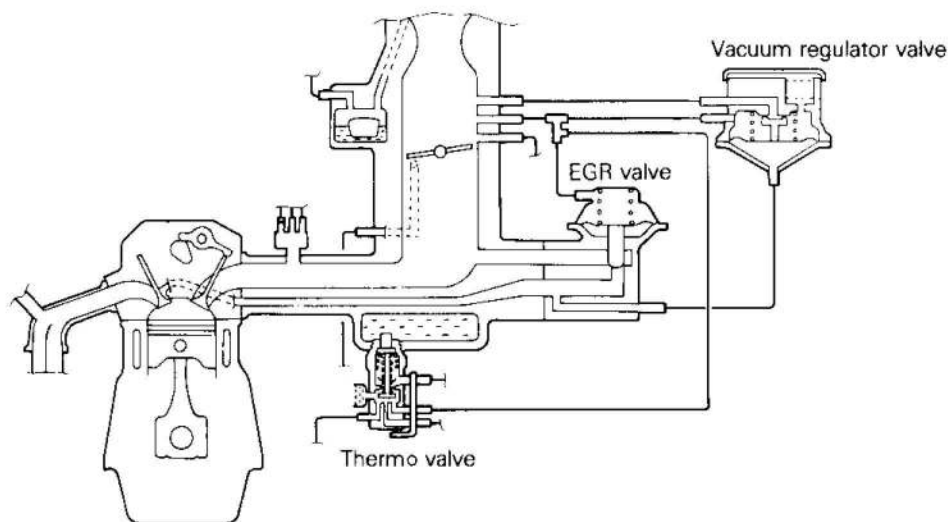

03G0041

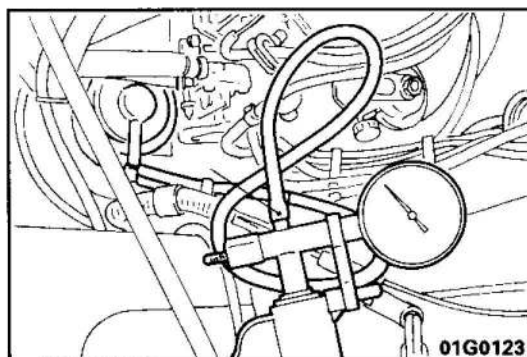

- (1) Disconnect the vacuum hose (green stripes) from the carburettor throttle body and connect the hand vacuum hose to the vacuum hose.
- (2) Inspect the following items with the engine cold [coolant temperature: 40°C (104°F) or less] and hot [coolant temperature: 80°C (176°F) or higher].

When engine is cold

Vacuum	Engine status	Normal condition
Try applying vacuum	3,500 r/min.	Vacuum leaks to atmosphere from thermo valve

When engine is hot

Vacuum	Engine status	Normal condition
Apply vacuum	Idling	Vacuum leaks
	3,500 r/min.	Leak the vacuum till it is approx. 80 mmHg (3.15 in.Hg)

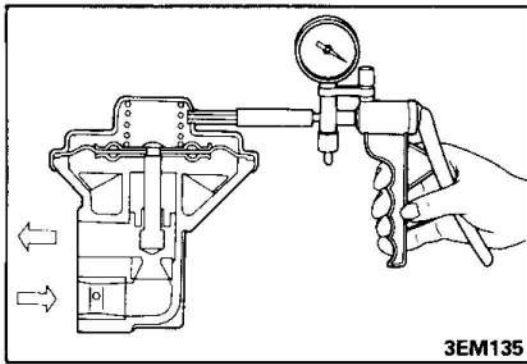

9. CHECKING OF EGR VALVE

- (1) Remove the EGR valve and inspect for sticking, carbon deposit, etc. If found, clean with a suitable solvent so that the valve seats correctly.
- (2) Connect a hand vacuum pump to the EGR valve.
- (3) apply a vacuum of 500 mmHg (19.7 in.Hg) and make sure that airtightness is maintained.
- (4) Check whether or not air is blown out of the EGR air passage.

Vacuum	Normal condition
40 mmHg (1.57 in.Hg) or less	Air is not blown out
220 mmhg (8.66 in.Hg) or more	Air is blown out

Caution

When mounting the EGR valve, use a new gasket and tighten to a torque of 19–28 Nm (1.9–2.8 kgm, 14–20 ft.lbs.).

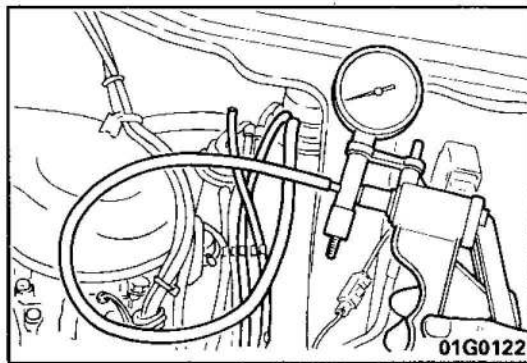

10. CHECKING OF VACUUM REGULATOR VALVE

- (1) Disconnect the vacuum hose (white stripes) from the vacuum regulator valve (VRV) and connect the hand vacuum pump to the VRV.
- (2) Apply a vacuum of 400 mmHg (15.7 in.Hg) to the VRV and inspect.

Engine status	Normal condition
Stop	Vacuum leaks
3,500 r/min.	Vacuum is maintained

11. CHECKING OF EGR VALVE CONTROL VACUUM

Refer to GROUP 13 FUEL — Service Adjustment Procedures (FBC).

12. CHECKING OF VRV CONTROL VACUUM

Refer to GROUP 13 FUEL — Service Adjustment Procedures (FBC).

13. CHECKING OF THERMO VALVE

Refer to the Purge Control System item.

14. CHECKING OF MIXTURE CONTROL VALVE (MCV)

Caution

Inspect with the engine warm.

- (1) Remove the air horn.
- (2) Start the engine and check the operation of the MCV valve and sound of the intake air when the throttle valve is rapidly opened and closed.

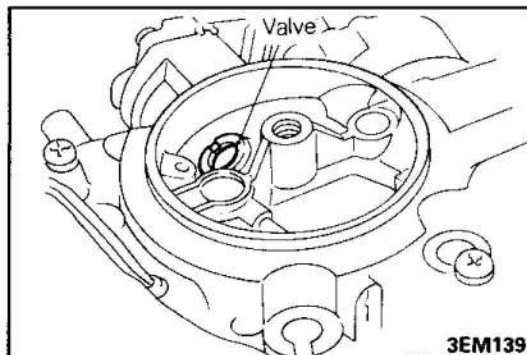

Engine speed	Normal condition	
	MCV valve operation	Intake air sound
Throttle lever operated	Opens and quickly closes	Audible
Idling	Closed	Inaudible

15. CHECKING OF INTAKE AIR TEMPERATURE CONTROL DEVICES

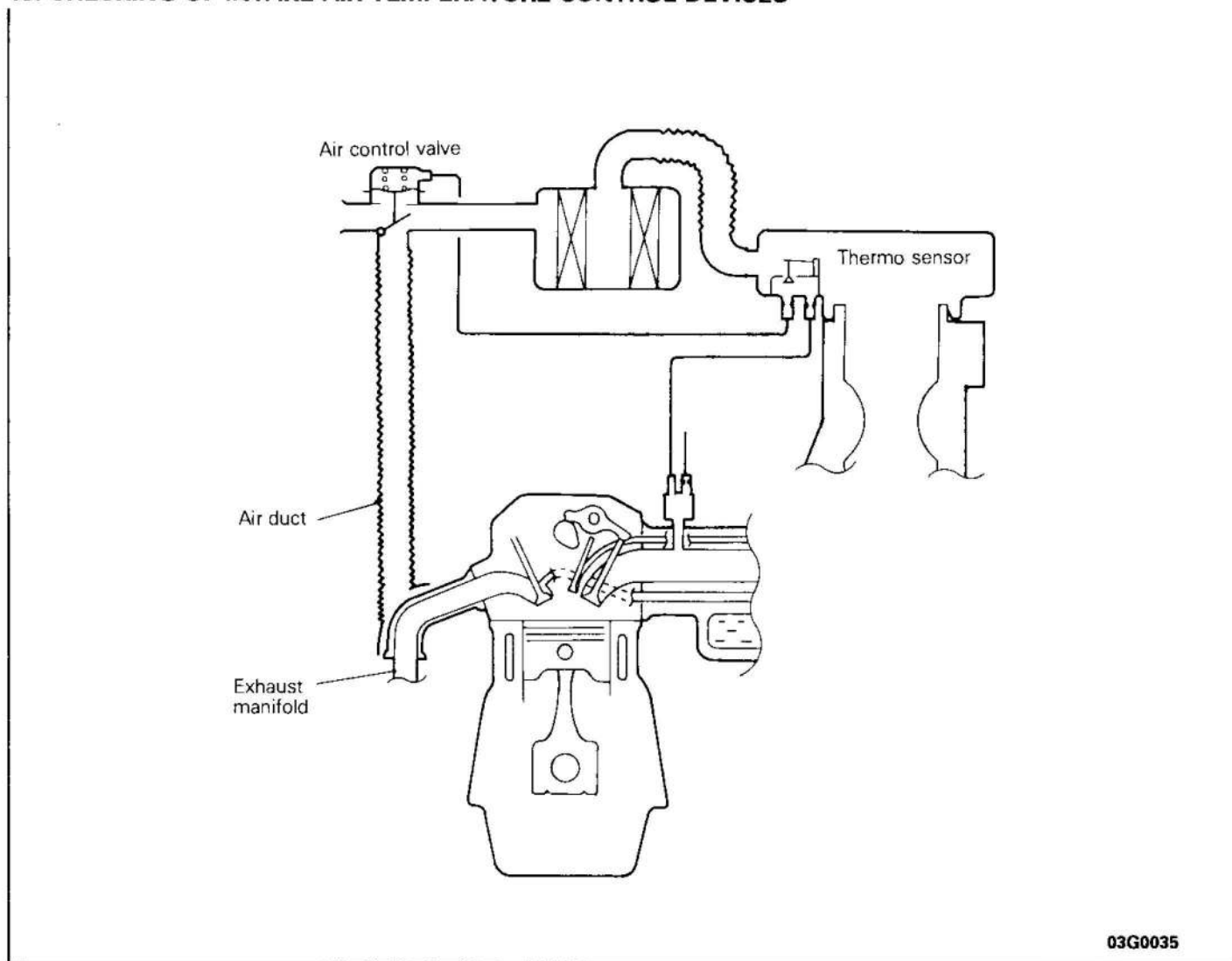

03G0035

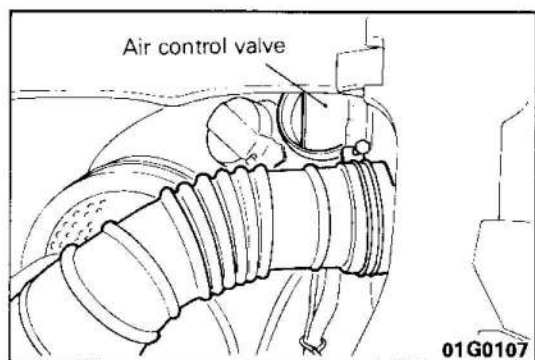

01G0107

- (1) Remove the air cleaner cover assembly and air duct.
- (2) Idle the engine and inspect the opening and closing of the air control valve.

Thermo sensor temperature	Normal condition
30°C (86°F) or less	The cool air port side closes
45°C (113°F) or higher	The cool air port side opens

NOTE

If necessary, cool by blowing compressed air or warm using a hair dryer, etc.

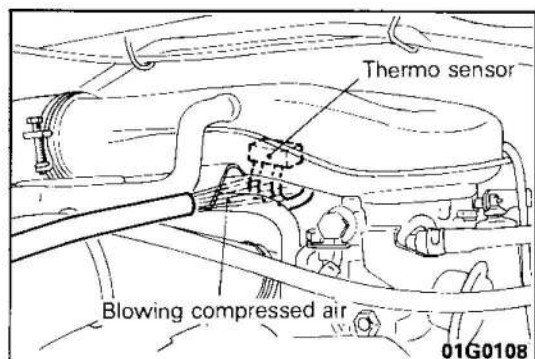

01G0108

- (3) Disconnect the intake manifold side vacuum hose from the thermo sensor, place a finger over the end of the hose and check for vacuum.

SERVICE ADJUSTMENT PROCEDURES (4G92, 4G63 engine) – Vehicles with FBC built from June 1994

E17FE-1

EMISSION CONTROL DEVICES REFERENCE TABLE

Related parts	Crankcase emission control system	Evaporative emission control system	Air fuel ratio control system	Three catalyst converter	Secondary air supply system*	Exhaust gas recirculation (EGR) system	Intake air temperature control system	Reference page for each part inspection
PCV valve	X							17-22-7
Bowl vent valve		X						17-17
Purge control valve*		X						17-29
Thermo valve		X				X		17-29
Canister		X						-
Overflow limiter (2-way valve)		X						-
FBC system component			X		X			Fuel (Group 13)
Three catalyst converter				X				-
Secondary air control valve (with reed valve)*					X			17-35-9
Secondary air control solenoid valve*					X			17-32
EGR valve						X		17-35-11
Vacuum regulator valve*						X		17-34
Check valve								-
Air thermo valve							X	17-22
Thermo sensor							X	17-22

NOTE

* : Vehicles with 4G63 engine.

VACUUM HOSE PIPING DIAGRAM

<4G92 engine>

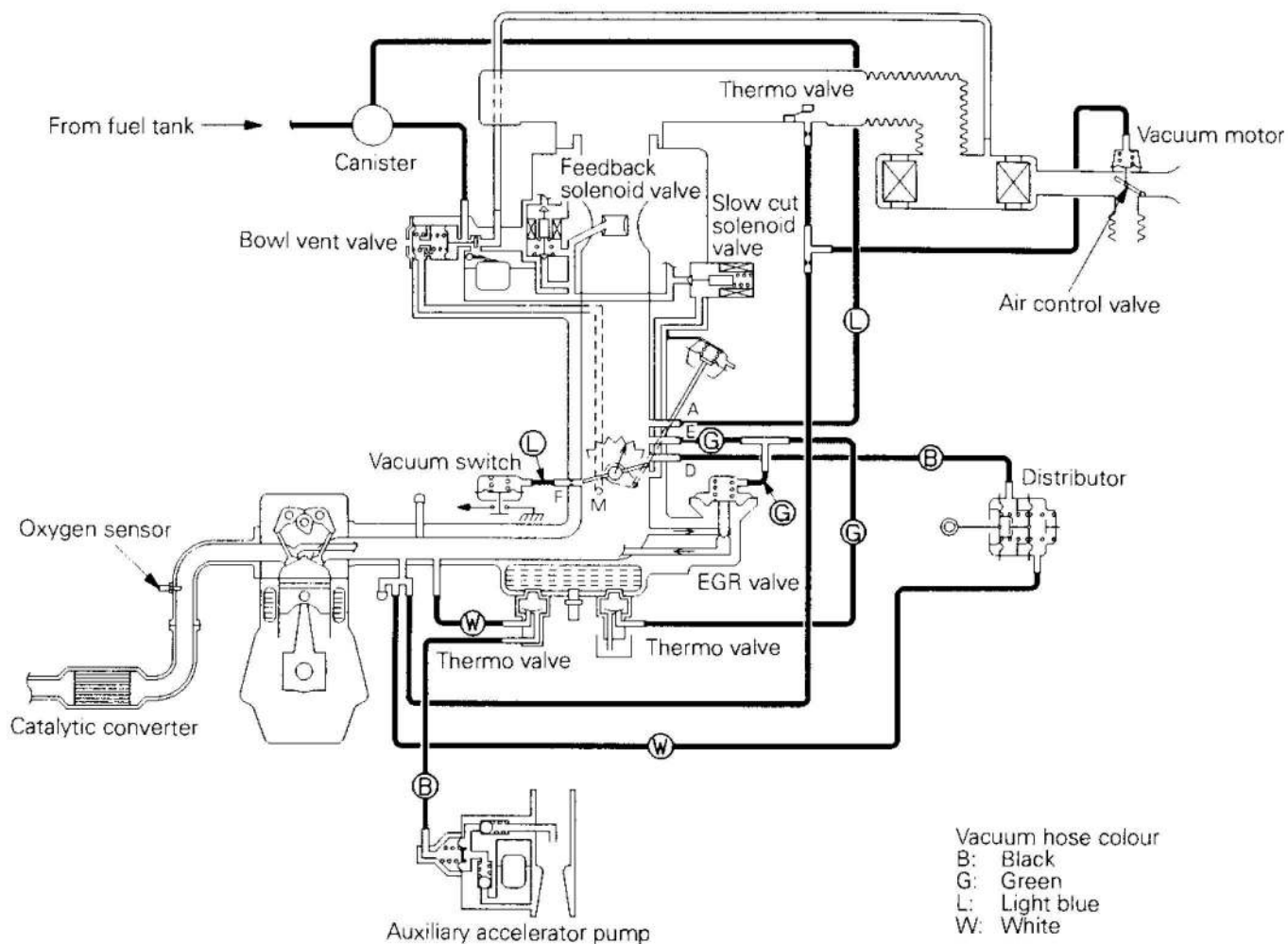

9FU0554

<4G63 engine>

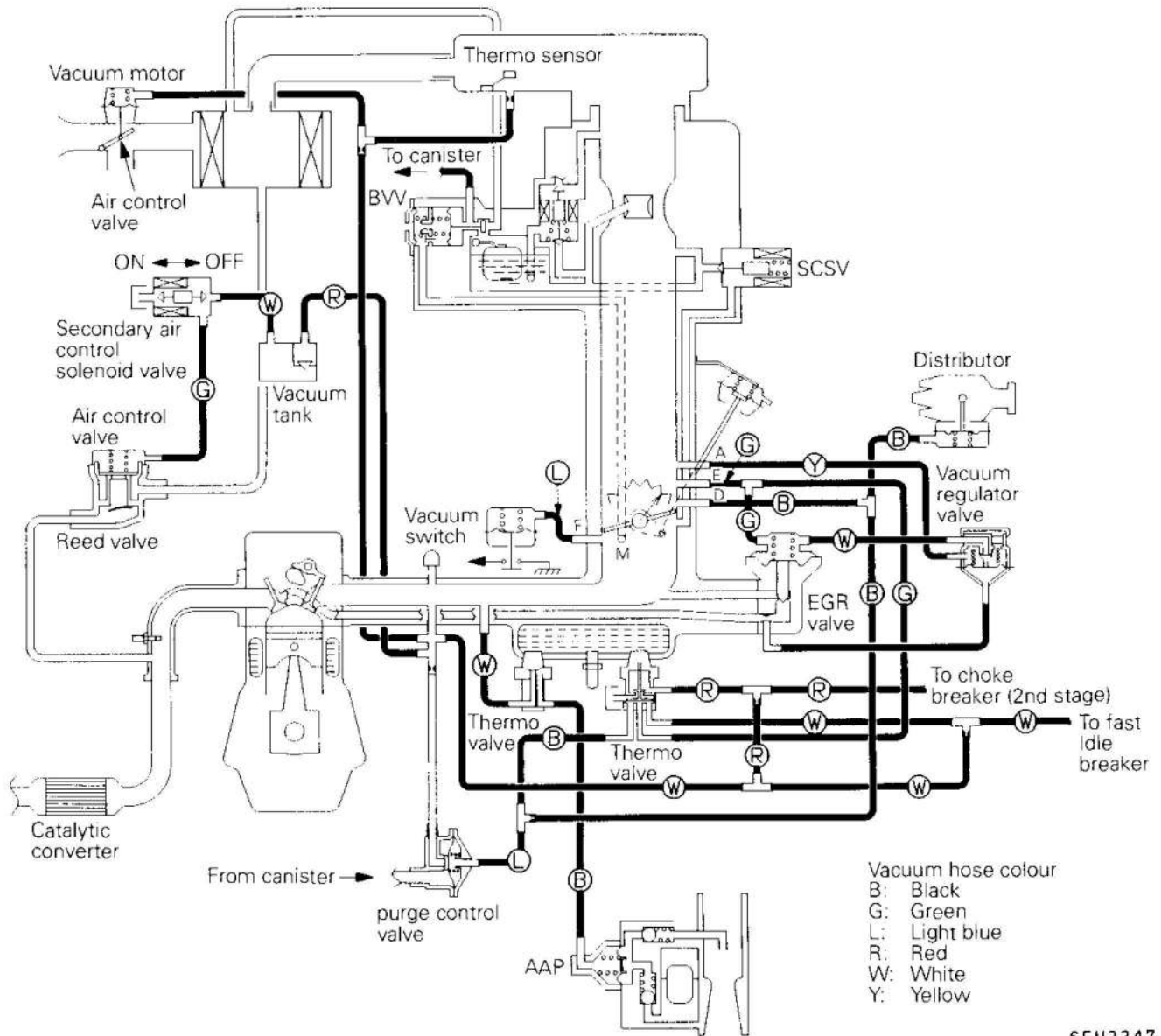

6FU2247

VACUUM HOSE LAYOUT

<4G92 engine>

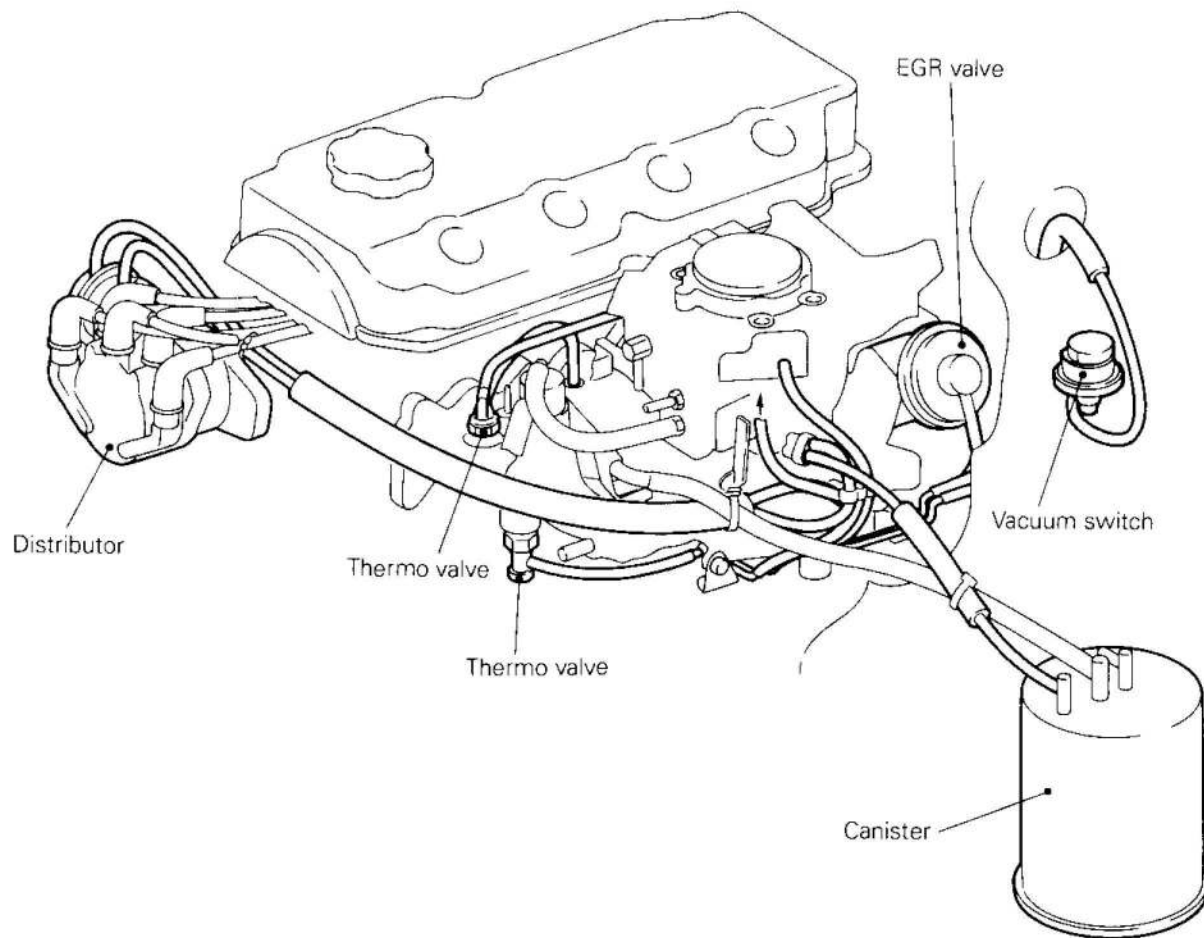

9FU0555

<4G63 engine>

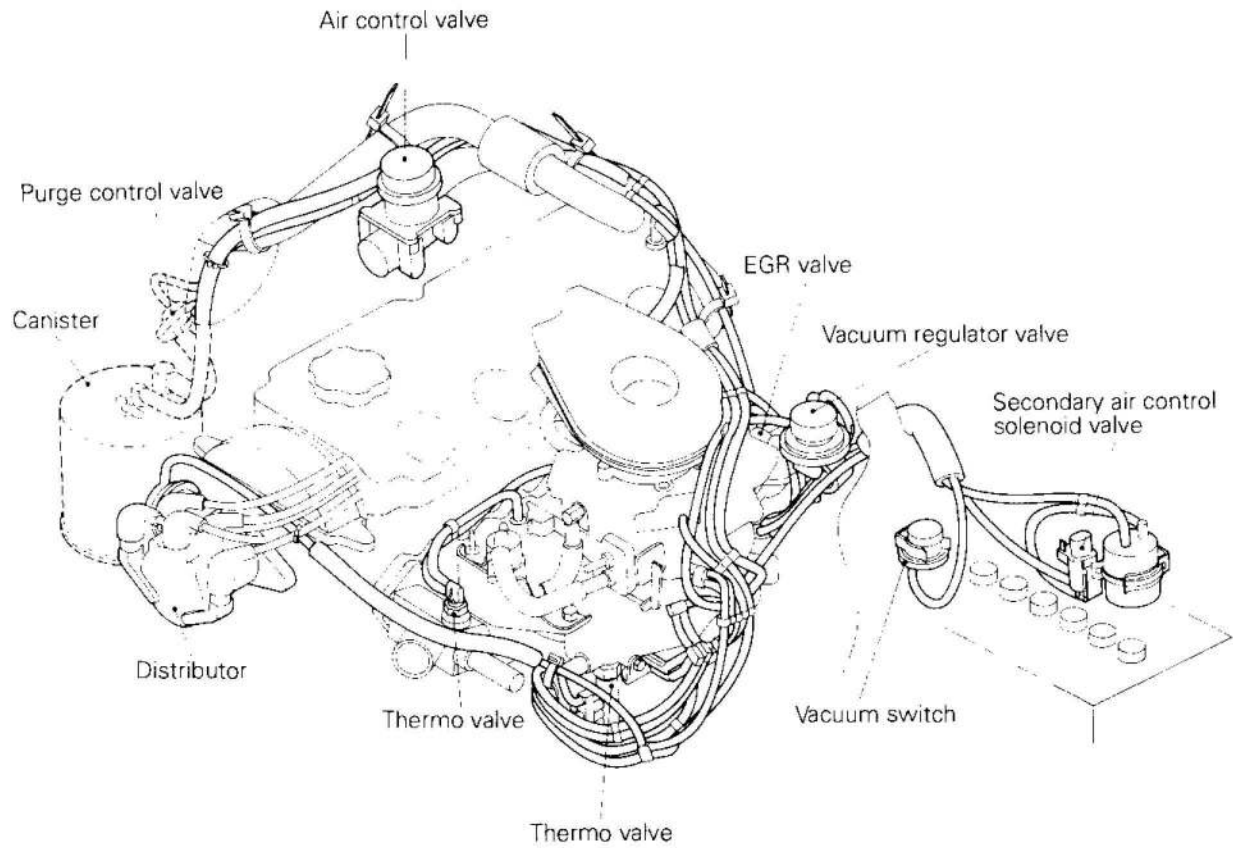

6FU2384

COMPONENT LAYOUT

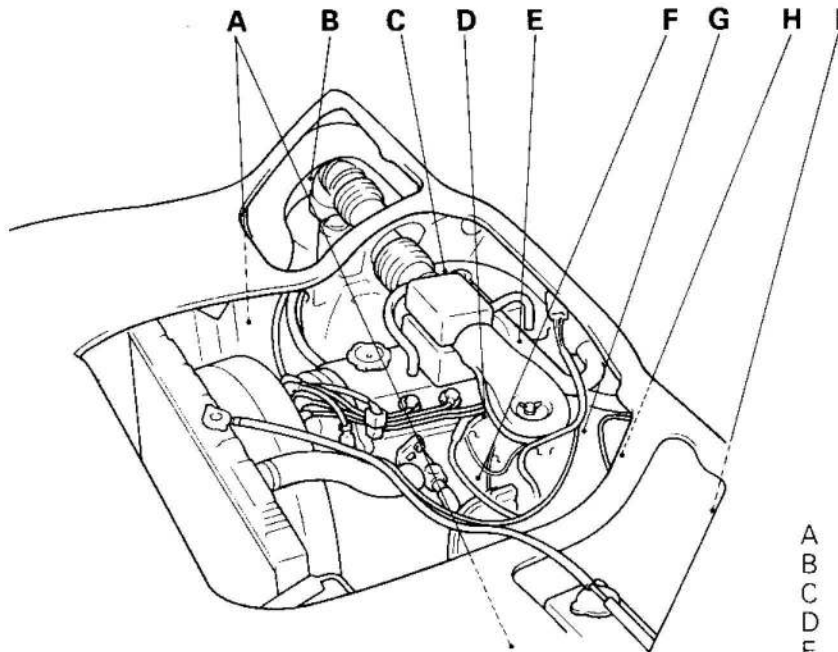

- A Canister
- B Air control valve
- C Secondary air control valve
- D Bowl vent valve
- E PCV valve
- F Thermo valve
- G EGR valve
- H Vacuum regulator valve
- I Secondary air control solenoid valve

16G0653

A Canister <4G92 engine>

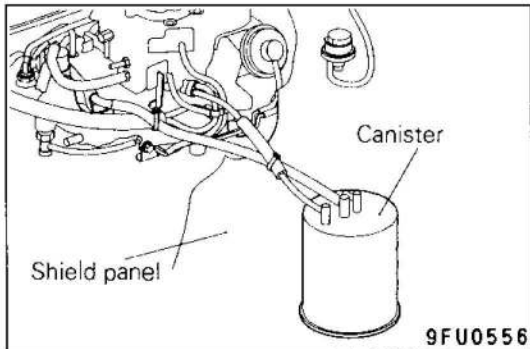

A Canister (4G63 engine)

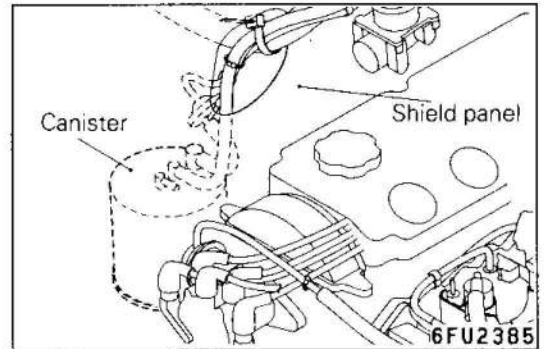

B Air control valve

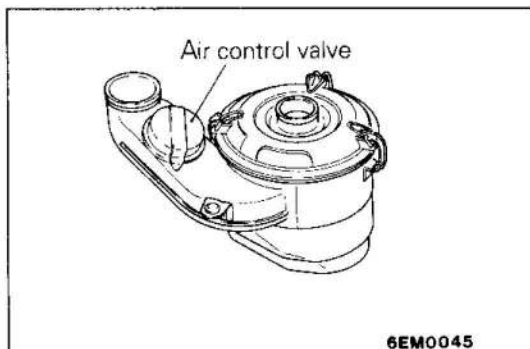

C Secondary air control valve

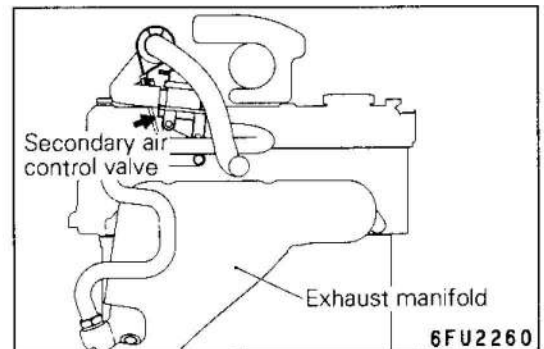

17-35-7 EMISSION CONTROL – Service Adjustment Procedures (4G92, 4G63 engine)

D Bowl vent valve

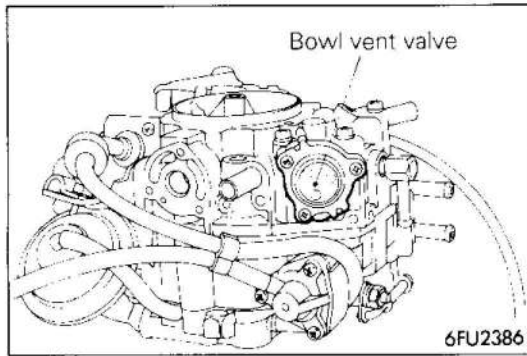

E PCV valve

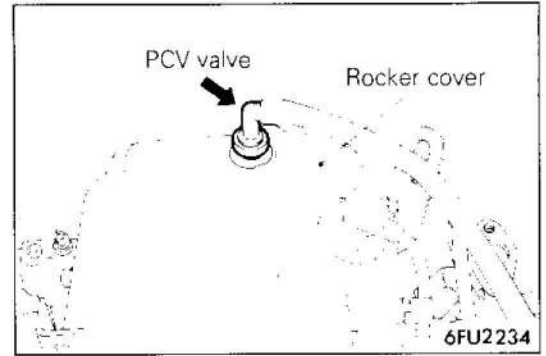

F Thermo valve <4G92 engine>

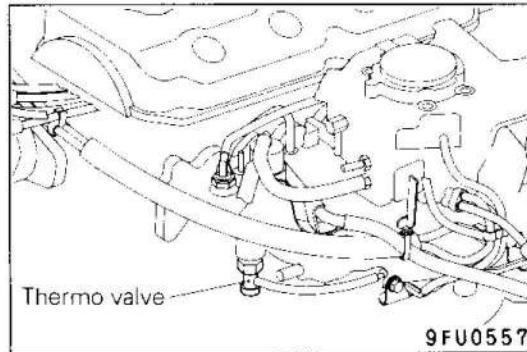

F Thermo valve <4G63 engine>

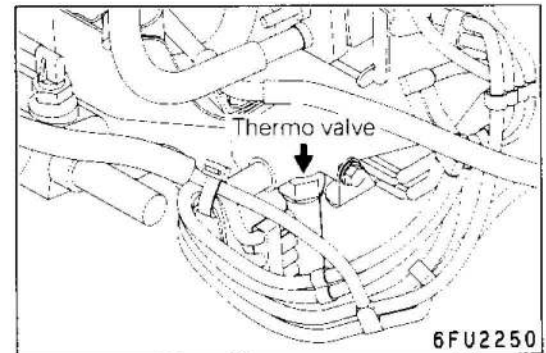

G EGR valve

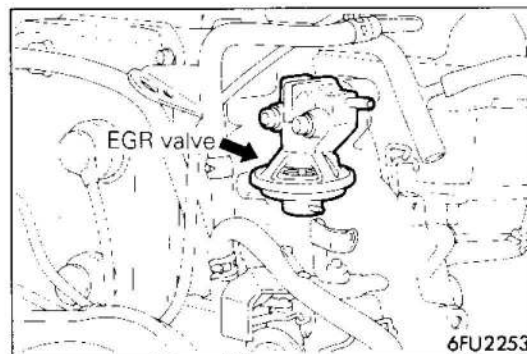

H Vacuum regulator valve <4G63 engine>

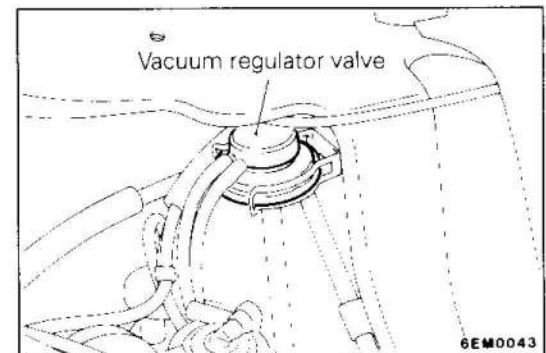

I Secondary air control solenoid valve

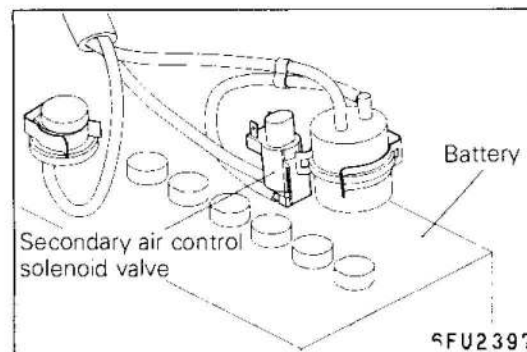

CAUTIONS ON INSPECTION

Refer to P.17-28.

CRANKCASE EMISSION CONTROL SYSTEM

Refer to P.17-22-7.

EVAPORATIVE EMISSION CONTROL SYSTEM

1. CHECKING OF PURGE CONTROL SYSTEM

<4G63 engine>

Refer to P.17-28.

2. CHECKING OF PURGE CONTROL VALVE (PCV)

<4G63 engine>

Refer to P.17-29.

3. CHECKING OF THERMO VALVE (PCV) <4G63 engine>

Refer to P.17-29.

4. CHECKING OF 2-WAY VALVE

Refer to GROUP 13 FUEL – Fuel Tank.

5. CHECKING OF CANISTER

Refer to GROUP 13 FUEL – Fuel Line.

6. CHECKING OF BOWL VENT VALVE (BVV)

Refer to P.17-17.

EXHAUST EMISSION CONTROL SYSTEM E17FCAF

1. CHECKING OF AIR-FUEL RATIO CONTROL SYSTEM (FBC)

Refer to GROUP 13 FUEL – Service Adjustment Procedures (FBC).

2. CHECKING OF ENGINE COOLANT TEMPERATURE SENSOR

Refer to GROUP 13 FUEL – Service Adjustment Procedures (FBC).

3. CHECKING OF ENGINE SPEED SENSOR

Refer to GROUP 13 FUEL – Service Adjustment Procedures (FBC).

4. CHECKING OF VACUUM SWITCH

Refer to GROUP 13 FUEL – Service Adjustment Procedures (FBC).

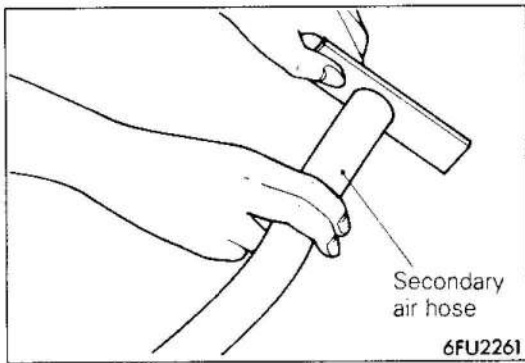

5. CHECKING OF SECONDARY AIR SUPPLY SYSTEM <4G63 engine>

Caution

Note that exhaust blowback sometimes occurs if the secondary air control valve is faulty.

- (1) Disconnect the air supply hose from the air cleaner, place a small steel plate over the end of the hose and check the air intake.

Engine coolant temperature	Engine status	Air suction
20–40°C (68–104°F)	2,000 r/min.	Yes
70°C (158°F) or higher	2,000 r/min.	Yes (within 70 sec. after starting the engine)
	Idling	No (70 sec. or more after starting the engine)
	Idling	Yes

6. CHECKING OF SECONDARY AIR CONTROL VALVE <4G63 engine>

- (1) Remove the secondary air control valve.
- (2) Blow air from the air cleaner side and make sure that the air does not pass through.
- (3) Connect a hand vacuum pump to the nipple of the secondary air control valve.
- (4) Apply a vacuum of 500 mmHg (19.7 in.Hg) and check that airtightness is maintained.
- (5) Apply a vacuum of 110 mmHg (4.3 in.Hg) and check whether or not air passes through.

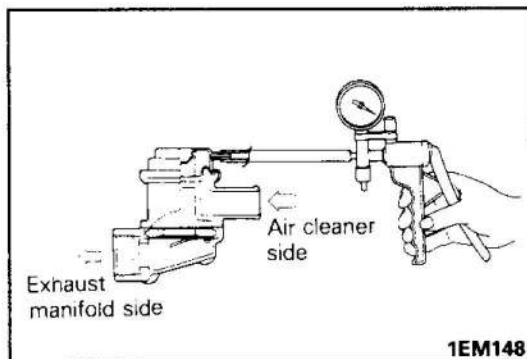
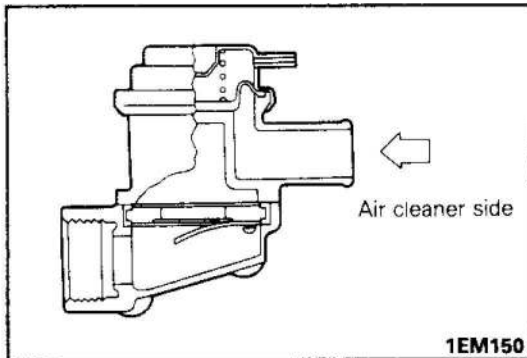

Direction of air	Normal condition
Air cleaner side → exhaust manifold side	Air passes through
Exhaust manifold side → air cleaner side	Air does not pass through

- (6) If inspection reveals any additional problems, replace the secondary air control valve.

7. CHECKING OF SECONDARY AIR CONTROL SOLENOID VALVE <4G63 engine>

Refer to P.17-32.

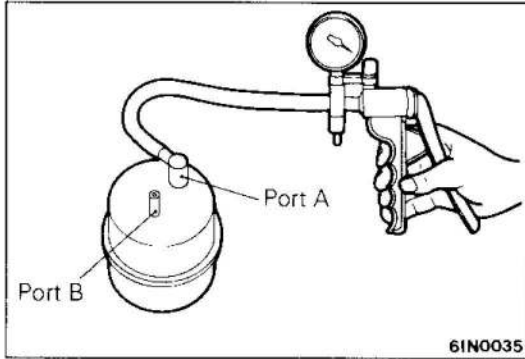

8. INSPECTION OF VACUUM TANK

- (1) Connect a hand vacuum pump to port A of the vacuum tank and apply a vacuum of 500 mmHg (20 in.Hg). Make sure that the tank is completely airtight with no vacuum leaks.
- (2) Connect a hand vacuum pump to port B and apply a vacuum. Make sure that the vacuum leaks.

9. CHECKING OF EGR SYSTEM <4G92 engine>

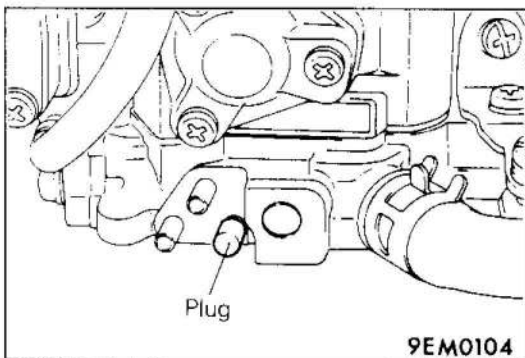
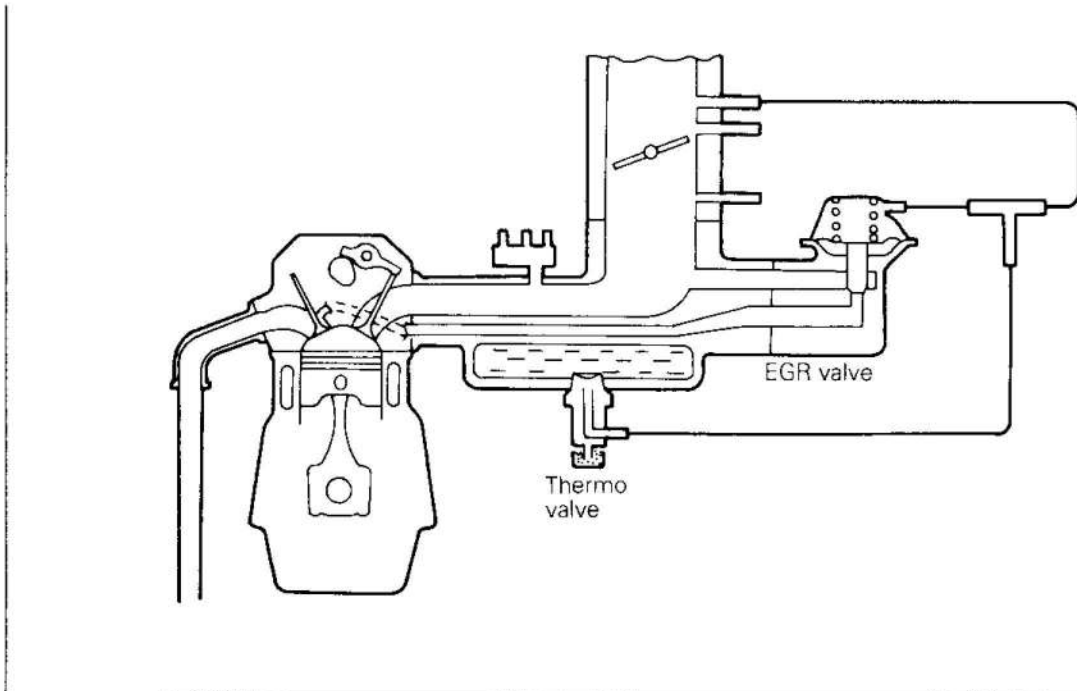

- (1) Disconnect the vacuum hose (green strip) from the carburetor, and connect a hand vacuum pump to the vacuum hose.
- (2) Plug the nipple from which the vacuum hose was disconnected.
- (3) When the engine is cold and hot, apply a vacuum while the engine is idling, and check the condition of the engine and the vacuum.

When engine is cold

[Engine coolant temperature: 40°C (104°F) or less]

	Engine status	Normal condition
Vacuum is applied	No change	Vacuum leaks

When engine is cold

[Engine coolant temperature: 80°C (176°F) or less]

	Engine status	Normal condition
Apply vacuum of 40 mm Hg (1.57 in.Hg)	No change	Vacuum is maintained
Apply vacuum of 120 mm Hg (4.72 in.Hg)	Idling becomes slightly unstable	

10. CHECKING OF EGR SYSTEM <4G63 engine>

Refer to P.17-33.

11. CHECKING OF EGR VALVE

- (1) Remove the EGR valve and inspect for sticking, carbon deposits, etc. If found, clean with a suitable solvent so that the valve seats correctly.
- (2) Connect a hand vacuum pump to the EGR valve.
- (3) Apply a vacuum of 500 mmHg (19.7 in.Hg) and make sure that airtightness is maintained. Check whether or not air is blown out of the EGR air passage.

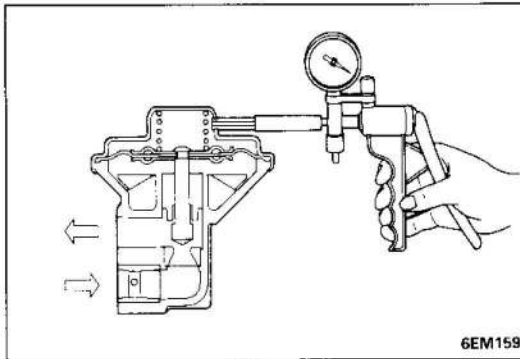

<4G92 engine>

Vacuum	Normal condition
40 mmHg (1.57 in.Hg) or less	Air is not blown out
120 mmHg (4.72 in.Hg) or more	Air is blown out

<4G63 engine>

Vacuum	Normal condition
50 mmHg (1.97 in.Hg) or less	Air is not blown out
220 mmHg (8.66 in.Hg) or more	Air is blown out

Caution

When mounting the EGR valve, use a new gasket and tighten to a torque of 17–26 Nm (1.7–2.6 kgm, 12–19 ft.lbs.)

12. CHECKING OF VACUUM REGULATOR VALVE

Refer to P.17-34.

13. CHECKING OF EGR VALVE CONTROL VACUUM

Refer to GROUP 13 FUEL – Service Adjustment Procedures (FBC).

14. CHECKING OF VRV CONTROL VACUUM

Refer to GROUP 13 FUEL – Service Adjustment Procedures (FBC).

15. CHECKING OF THERMO VALVE <4G92 engine>

Refer to P.17-22-8.

16. CHECKING OF THERMO VALVE <4G64 engine>

Refer to the Purge Control System item.

17. CHECKING OF INTAKE AIR TEMPERATURE CONTROL DEVICES

Refer to P.17-22-10.

NOTES

SERVICE ADJUSTMENT PROCEDURES (4G64, G64B engines) – Vehicles built up to May 1994

E17FE-2

EMISSION CONTROL DEVICE REFERENCE TABLE

Related parts	Emission control system	Crankcase emission control system	Evaporative emission control system	Jet air system	Air fuel ratio control system	Three catalyst converter	Exhaust gas recirculation (EGR) system	Reference page for each part inspection
PCV valve		X						17-43
Purge control valve			X					17-45
Canister			X					-
Overflow limiter (2-way valve)			X					Fuel (Group 13)
Jet valve				X				Engine (Group 11)
MPI system component			X		X			Fuel (Group 13)
Three catalyst converter						X		17-49
EGR valve							X	17-47
Thermo valve							X	17-48

NOTE: This table is vehicles for Europe (with oxygen sensor, non-leaded gasoline).

COMPONENT LAYOUT

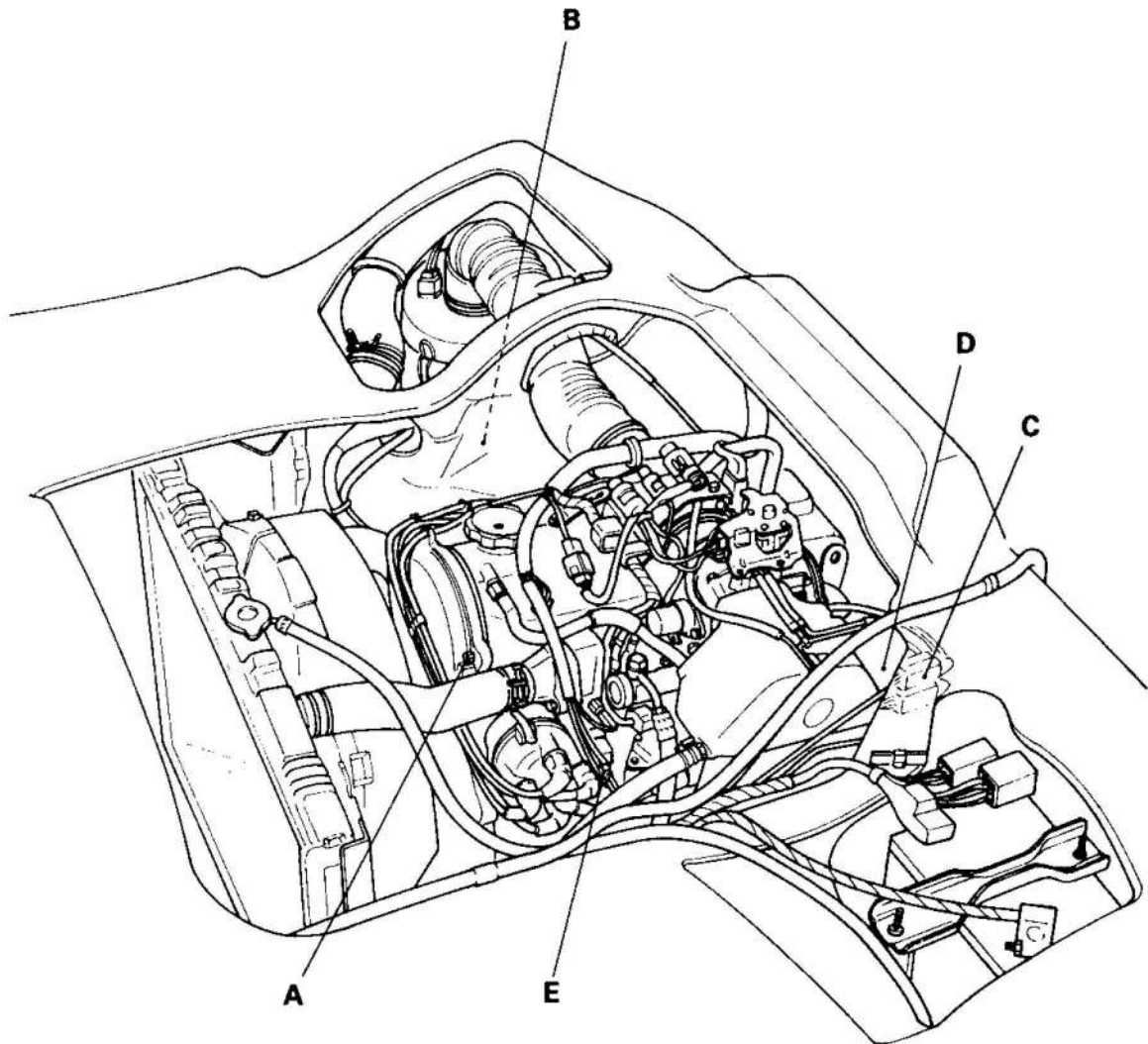

6EM0002

- A PCV valve
- B Canister
- C Purge control solenoid valve
- D EGR valve
- E Thermo valve

17-38 EMISSION CONTROL – Service Adjustment Procedures (4G64, G64B engines)

A PCV valve

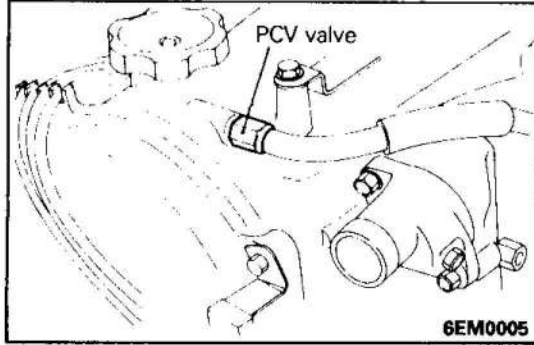

B Canister

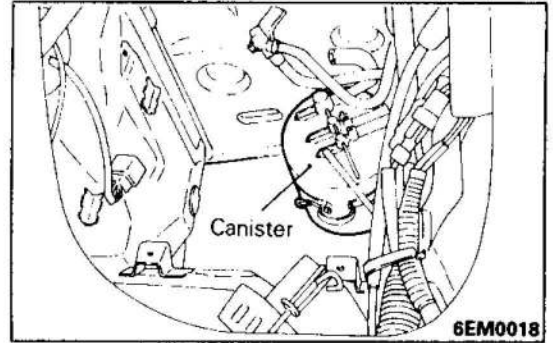

C Purge control solenoid valve

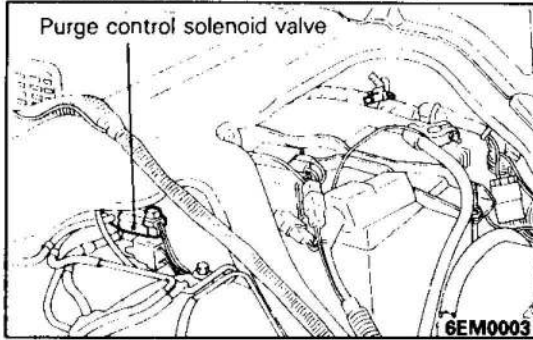

D EGR valve

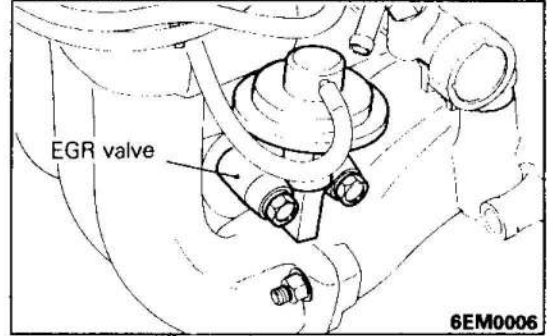

E Thermo valve

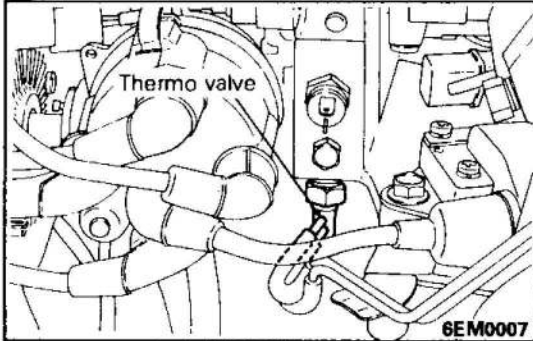

VACUUM HOSE PIPING DIAGRAM

Vehicles for Europe

- 1* Injector
- 3* Idle speed control servo
- 4* Purge control solenoid
- 5* Fuel pressure solenoid valve (Only applies to vehicles built up to November 1988.)
- Fuel pump control (control relay)
- Air conditioner power relay
- Ignition timing control

- 10* Barometric pressure sensor
 - Ignition switch
 - Power source
 - Vehicle-speed sensor
 - Air conditioner switch
-
- 1* Oxygen sensor
 - 2* Air flow sensor
 - 3* Intake air temperature sensor
 - 4* Coolant temperature sensor
 - 5* Throttle position sensor
 - 6* Idle switch
 - 7* Cylinder top dead center
 - 8* Crank angle sensor
 - 9* Motor position sensor

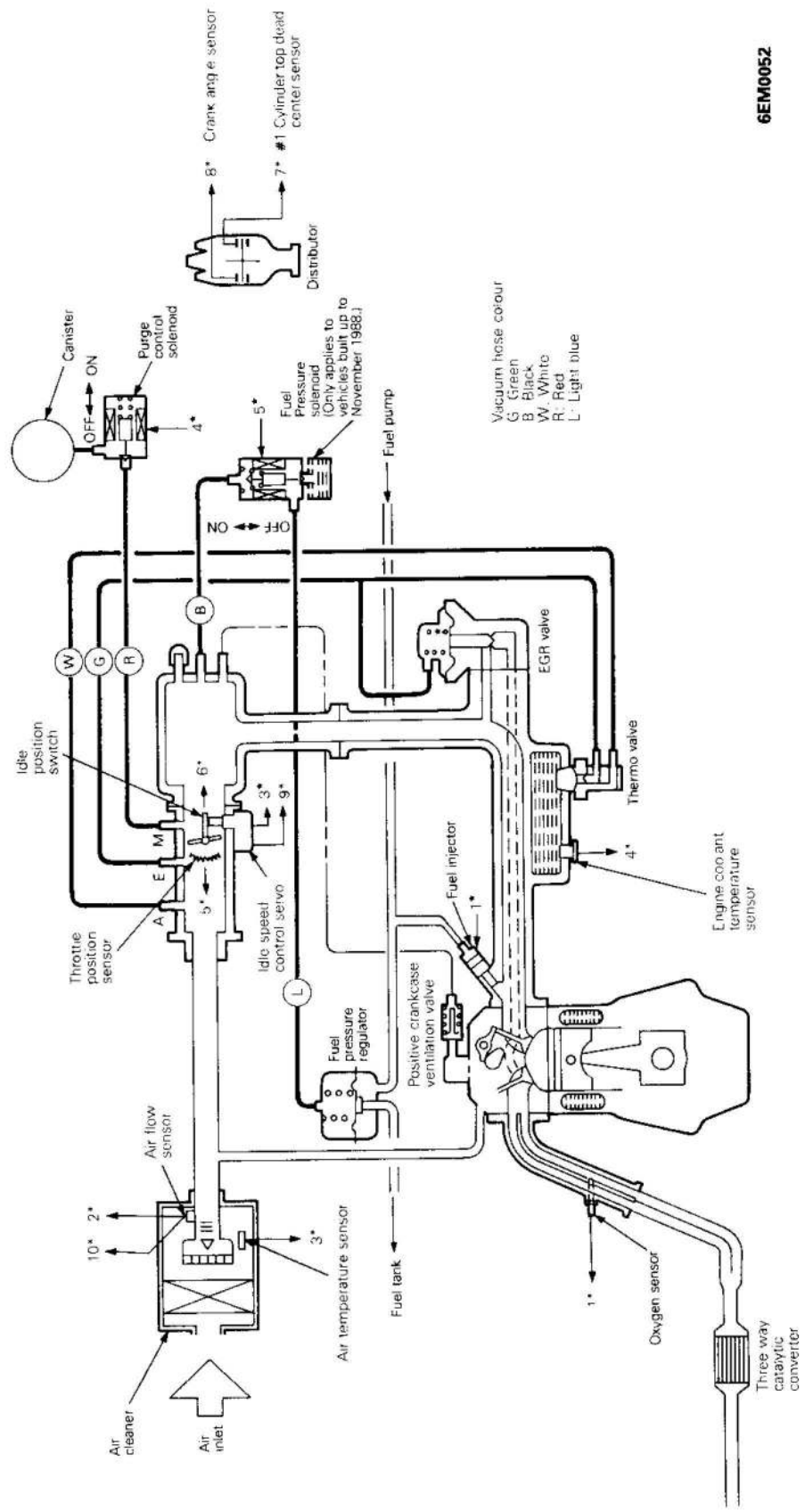

Vacuum hose colour
 G Green
 B Black
 W White
 R Red
 L Light blue

6EM0052

17-40 EMISSION CONTROL – Service Adjustment Procedures (4G64, G64B engines)

Vehicles for Australia

- 1* Injector
- 3* Idle speed control servo
- 4* Purge control solenoid
- 5* Fuel pressure solenoid valve
- Fuel pump control (control relay)
- Air conditioner power relay
- Ignition timing control

Electronic control unit

- 10* Barometric pressure sensor
 - Ignition switch
 - Power source
 - Vehicle-speed sensor
 - Air conditioner switch
 - Inhibitor switch (Automatic transmission)
- 1* Oxygen sensor
 - 2* Air flow sensor
 - 3* Intake air temperature sensor
 - 4* Coolant temperature sensor
 - 5* Throttle position sensor
 - 6* Idle switch
 - 7* Cylinder top dead center sensor
 - 8* Crank angle sensor
 - 9* Motor position sensor

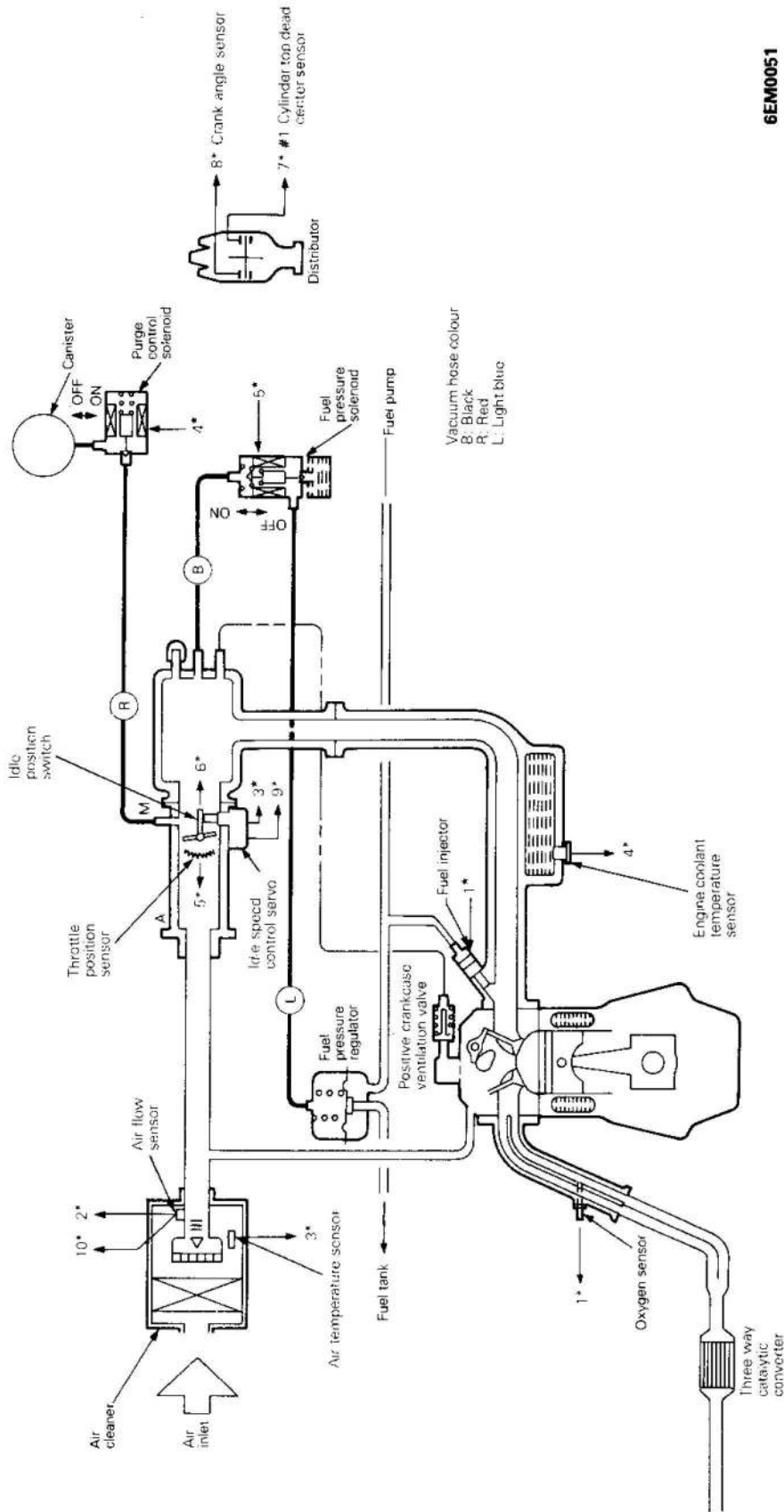

6EM0051

Vehicles for Hong Kong

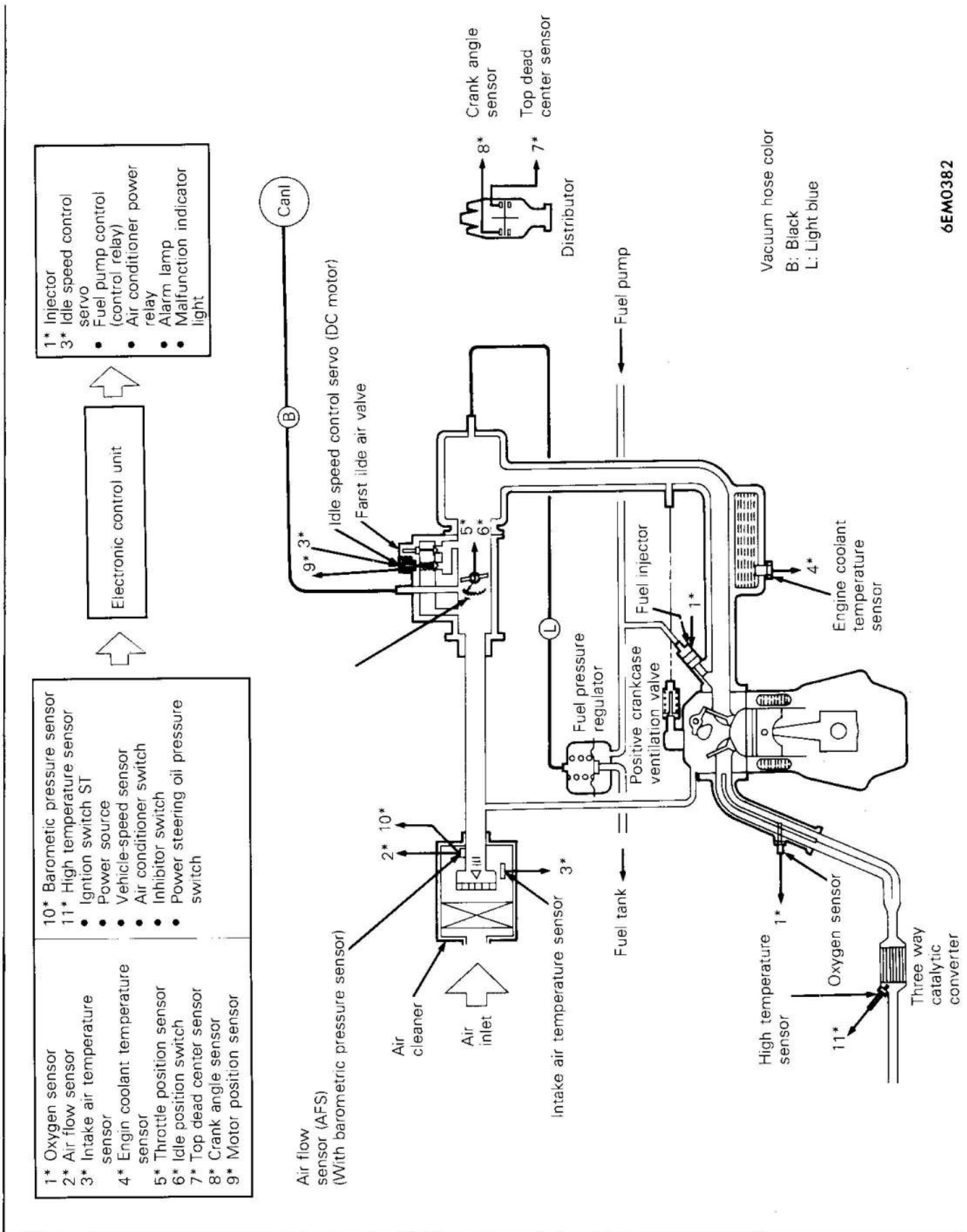

6EM0382

17-40-2 EMISSION CONTROL – Service Adjustment Procedures (4G32, 4G33, 4G63 engines)

NOTE

VACUUM HOSE LAYOUT

Vehicles for Europe

[Vehicles built up to October 1989]

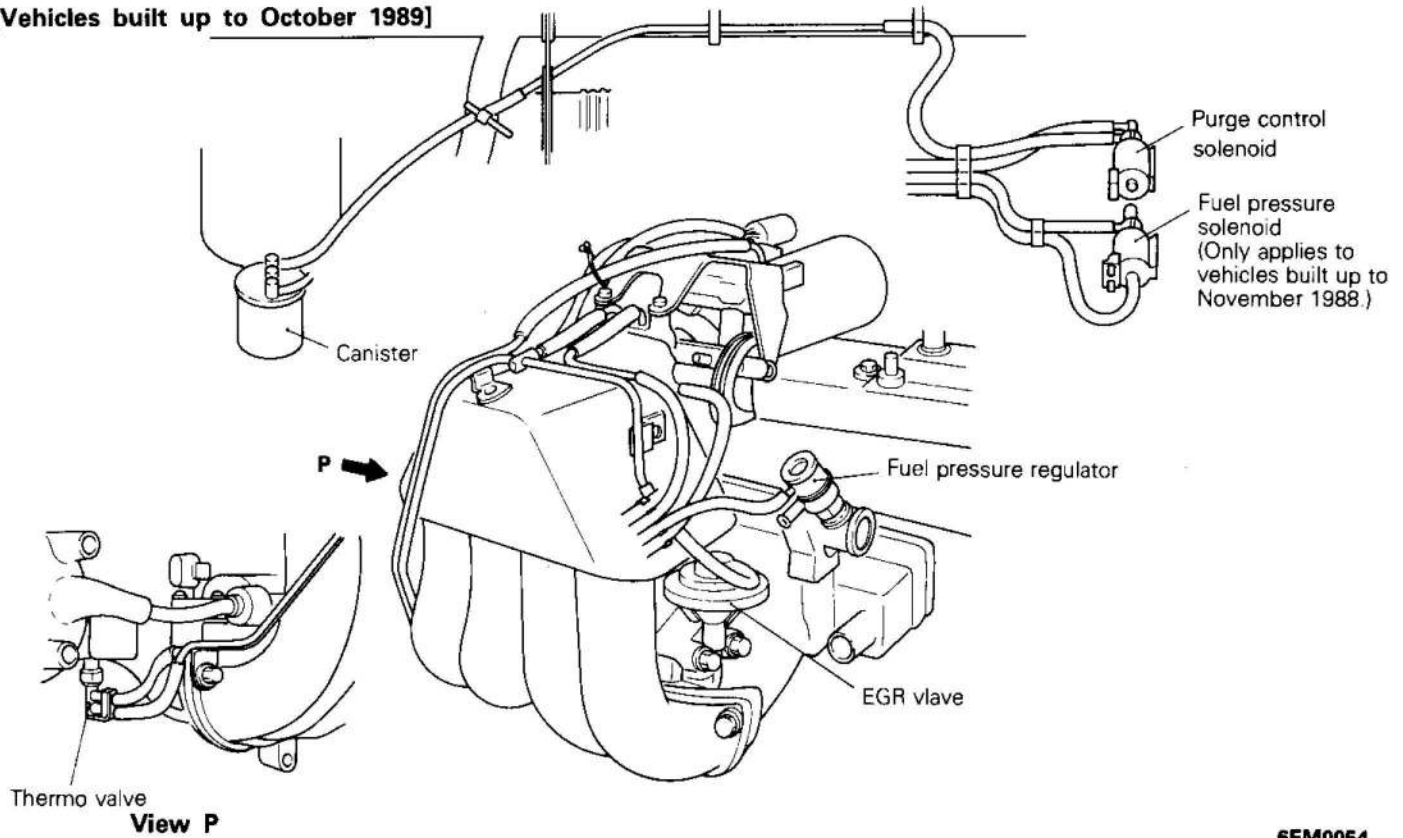

6EM0054

[Vehicles built from November 1989]

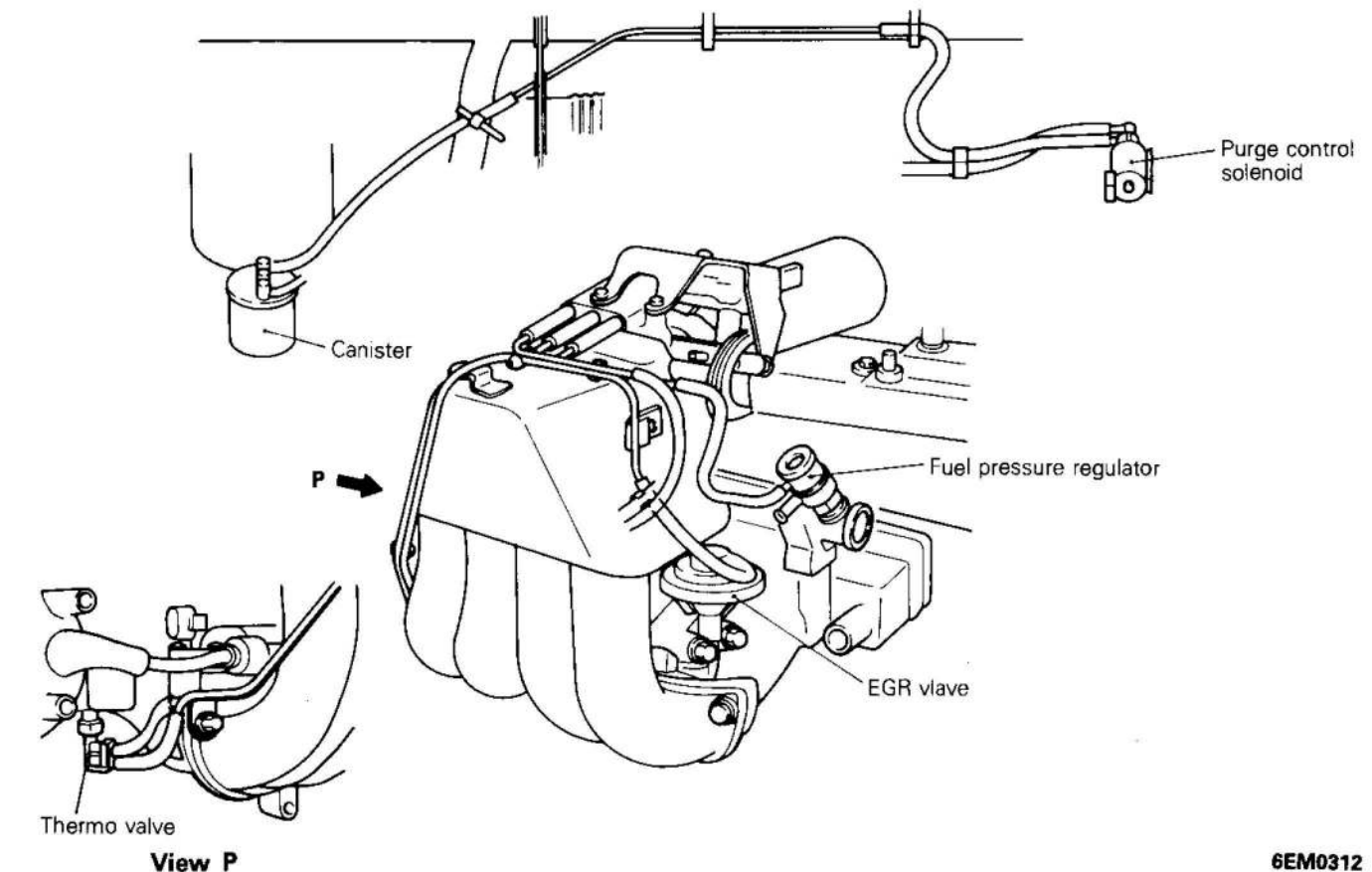

6EM0312

Vehicles for Hong Kong

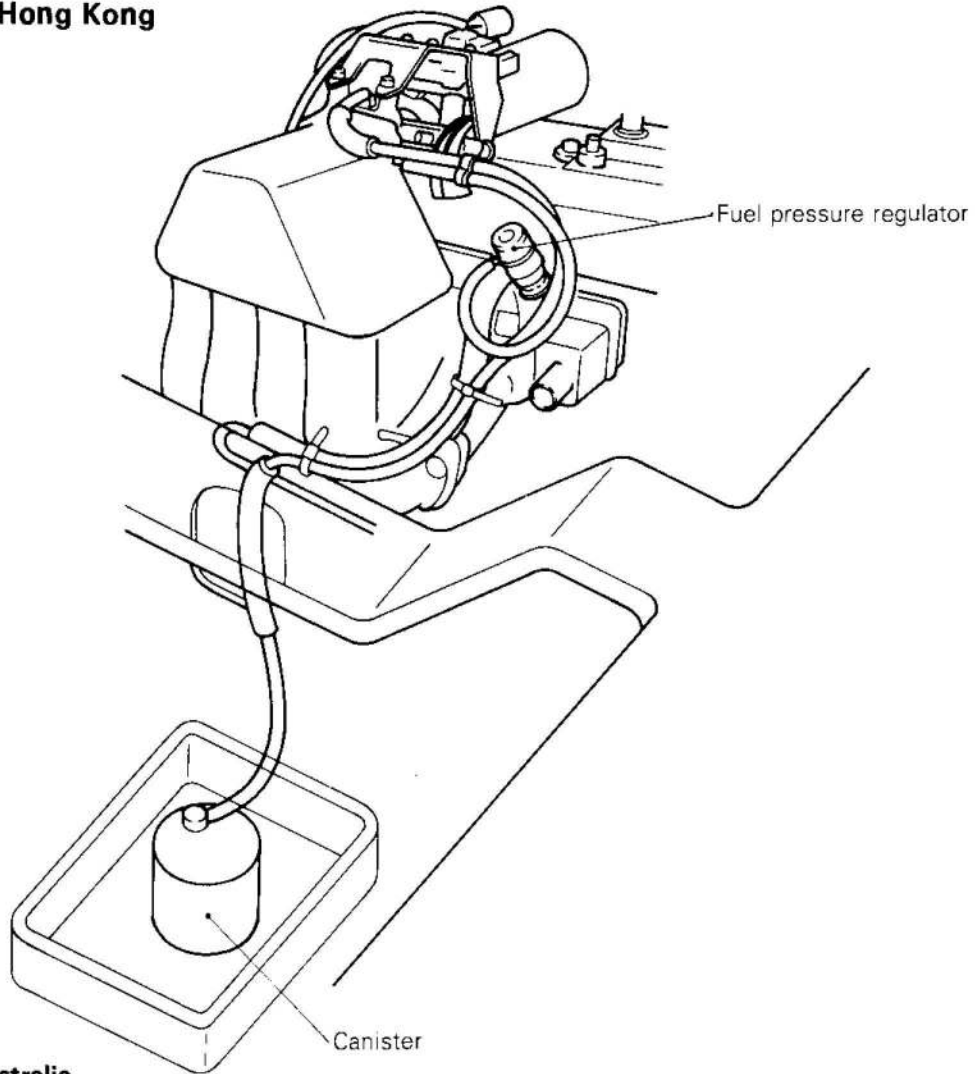

Vehicles for Australia

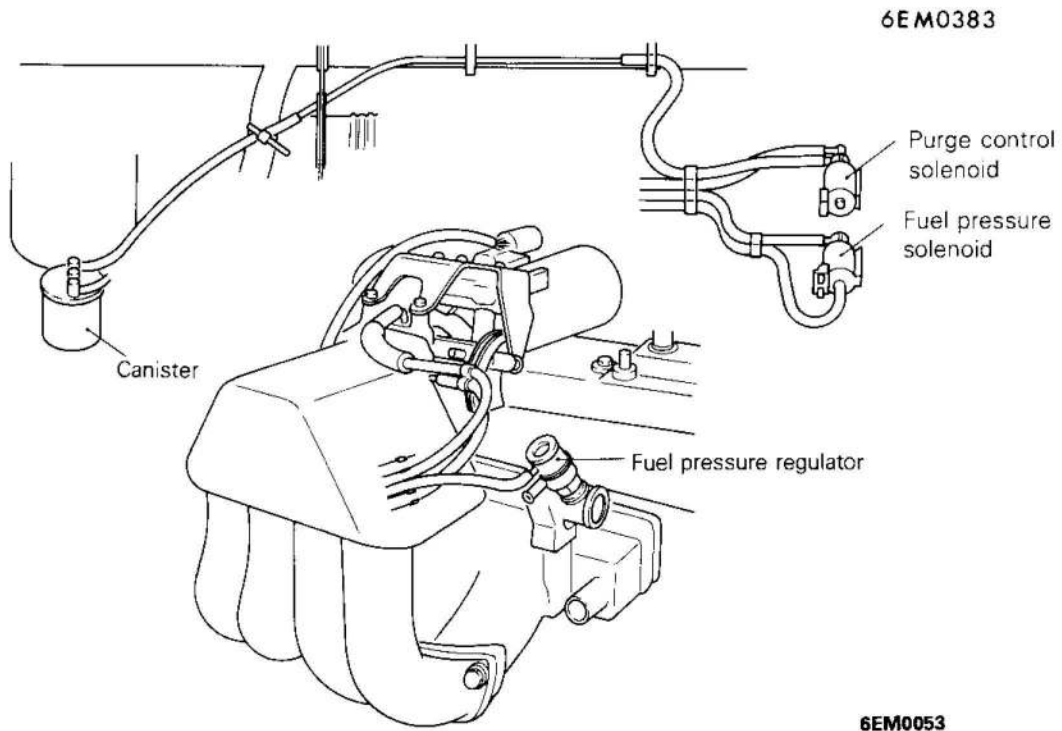

CAUTIONS ON INSPECTION

E17FFAB

1. Inspect the various devices only after completing engine adjustment.
2. Inspect the hoses to make sure there are no disconnections, connection errors or damage.
3. Make sure there is no hose, pipe or port clogging, or cracks or damage in the hoses and pipes.
4. When replacing device hoses, always mount the replacement hose in the same position (direction) as the original.
5. When finished, check the connections as described in the service manual.

CRANKCASE EMISSION CONTROL SYSTEM

E17FAAB2

1. CHECKING OF POSITIVE CRANKCASE VENTILATION (PCV) VALVE

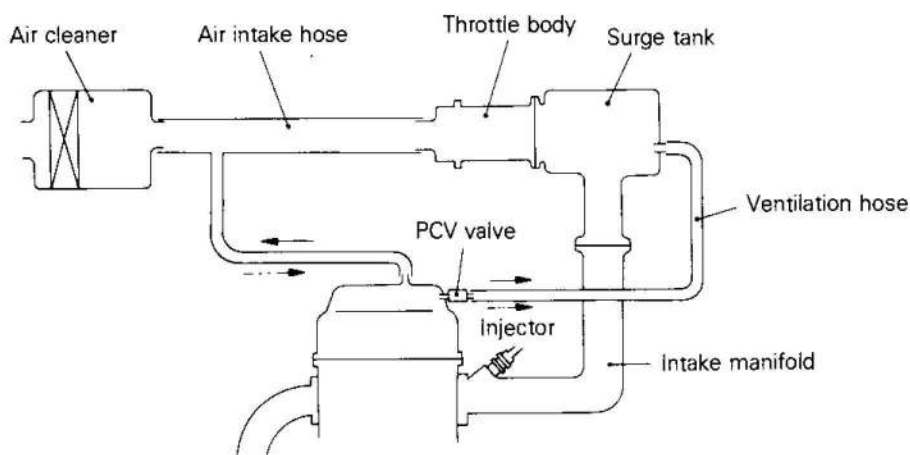

6EM120

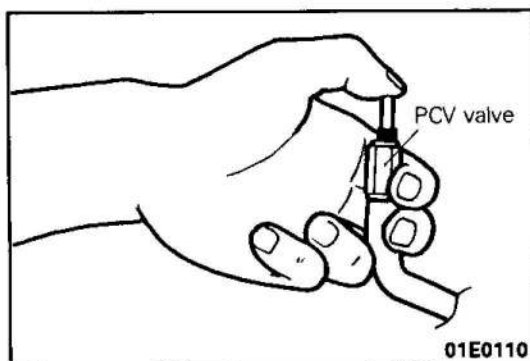

- (1) After disconnecting the ventilation hose from the positive crankcase ventilation (PCV) valve, remove the PCV valve from the rocker cover and again connect the ventilation hose.
- (2) Run the engine at idling speed, place a finger over the end of the PCV valve opening and check the intake manifold vacuum.

NOTE

The plunger inside the PCV valve will move back and forth.

17-44 EMISSION CONTROL – Service Adjustment Procedures (4G64, G64B engines)

- (3) If vacuum cannot be felt against the finger, clean the PCV valve and ventilation hose with cleaning solvent, or else replace.

EVAPORATIVE EMISSION CONTROL SYSTEM

E17FBAE

2. CHECKING OF PURGE CONTROL SYSTEM (Vehicles for Europe and Australia)

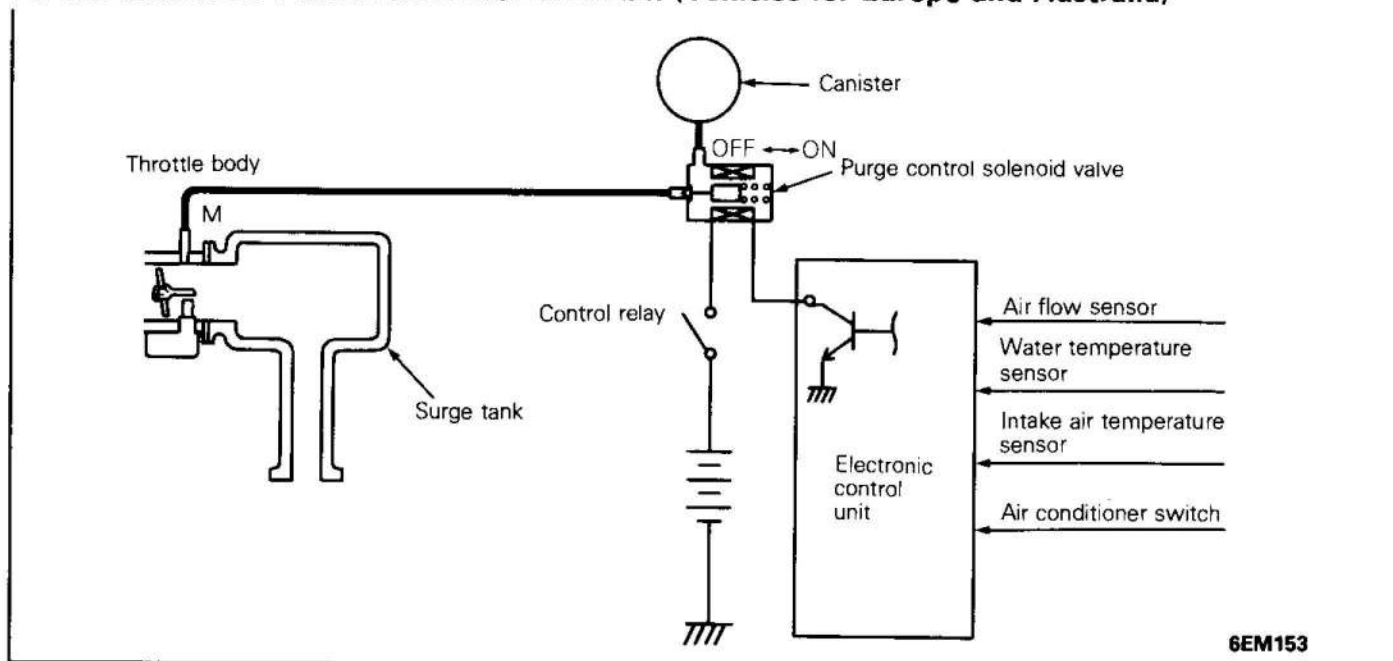

Vehicles for Europe built up to October 1989 and vehicles for Australia built up to June 1989

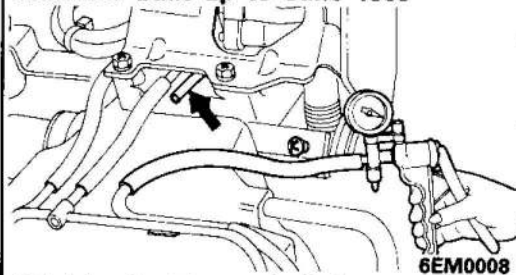

Vehicles for Europe built from November 1989 and vehicles for Australia built from July 1989

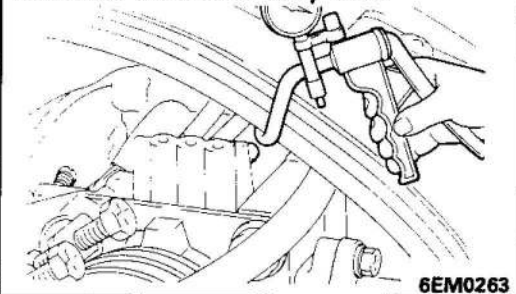

- (1) Disconnect the vacuum hose (red stripes) from the throttle body and connect it to a hand vacuum pump.

- (2) Inspect the following items with the engine cold [coolant temperature: 60°C (140°F) or less] and hot [coolant temperature: 70°C (158°F) or higher].

When engine is cold

Vacuum	Engine status	Air conditioner switch	Normal condition
400 mmHg (15.7 in.Hg)	2,500 r/min.	—	Vacuum is maintained

When engine is hot

Vacuum	Engine status	Air conditioner switch	Normal condition
400 mmHg (15.7 in.Hg)	Idling	ON	Vacuum leaks
	2,500 r/min.	OFF	Vacuum is maintained
Vacuum will leak for approximately 3 minutes after the engine is started. After 3 minutes have elapsed, the vacuum will be maintained momentarily, after which it will again leak.			

3. CHECKING OF PURGE CONTROL SOLENOID VALVE <Vehicles for Europe and Australia>

NOTE

When disconnecting the vacuum hose, always make a mark so that the hose can be reconnected at original position.

- (1) Disconnect the vacuum hose (black stripes, red stripes) from the solenoid valve.
- (2) Disconnect the harness connector.
- (3) Connect a hand vacuum pump to the nipple to which the vacuum hose with red stripes was connected.

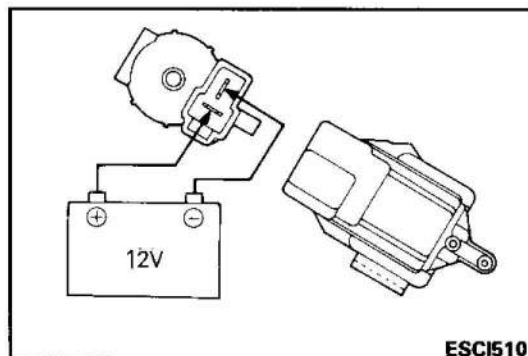
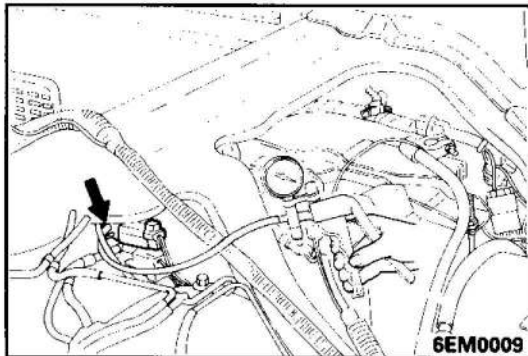

- (4) Check airtightness by applying a vacuum with voltage applied directly from the battery to the purge control solenoid valve and without applying voltage.

Battery voltage	Normal condition
Applied	Vacuum leaks
Not applied	Vacuum maintained

17-46 EMISSION CONTROL – Service Adjustment Procedures (4G64, G64B engines)

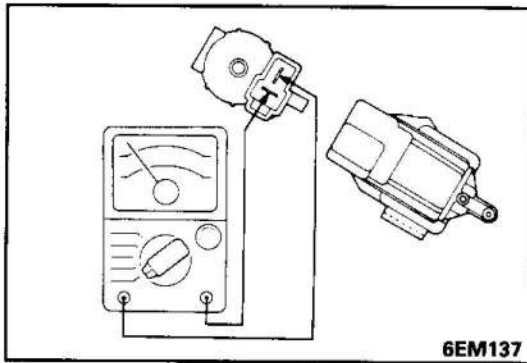

- (5) Measure the resistance between the terminals of the solenoid valve.

Standard value: 38–44Ω [at 20°C (68°F)]

4. CHECKING OF AIR FLOW SENSOR

Refer to GROUP 13 FUEL – Service Adjustment Procedures (MPI).

5. CHECKING OF COOLANT TEMPERATURE SENSOR

Refer to GROUP 13 FUEL – Service Adjustment Procedures (MPI).

6. CHECKING OF INTAKE AIR TEMPERATURE SENSOR

Refer to GROUP 13 FUEL – Service Adjustment Procedures (MPI).

7. CHECKING OF AIR CONDITIONER SWITCH

Operate the switch, and check the continuity between the terminals.

Terminal / Switch position	1	2	3	Indication lamp	4	Color
OFF			○	⊕	○	Amber
ON (pressed inward)	○	○	○	⊕	○	Green

NOTE

○—○ indicates that there is continuity between the terminals.

8. CHECKING OF 2-WAY VALVE

Attach a clean hose and check the operation of the 2-way valve

Inspection procedure	Normal condition
Lightly blow from inlet side (fuel tank side).	Air passes through with a slight feeling of resistance.
Lightly blow from outlet side (canister side).	Air passes through.

9. CHECKING OF CANISTER

Refer to GROUP 13 FUEL – Fuel Line.

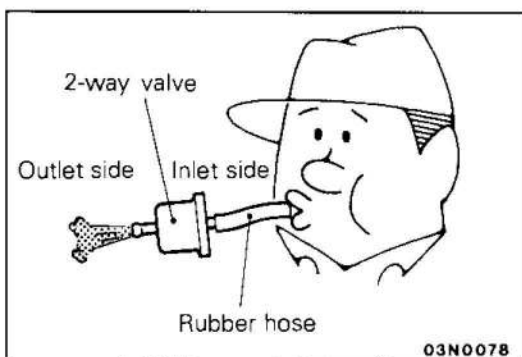
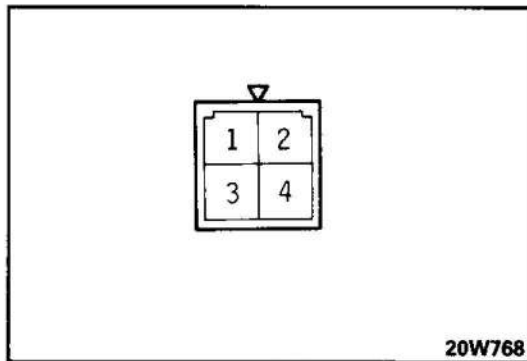

EXHAUST EMISSION CONTROL SYSTEM E17FCAG

1. CHECKING OF AIR FUEL RATIO CONTROL SYSTEM

Refer to GROUP 13–Service Adjustment Procedure (MPI).

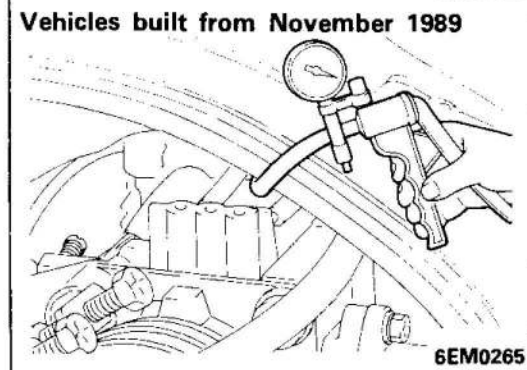
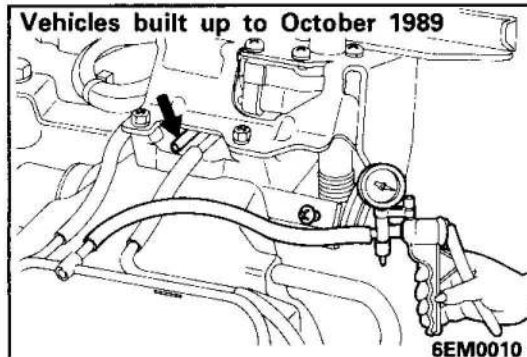

2. CHECKING OF EXHAUST GAS RECIRCULATION (EGR) SYSTEM (Vehicles for Europe)

(1) Disconnect the vacuum hose (green stripes) from the throttle body and connect it to a hand vacuum pump.

(2) Inspect the following items with the engine cold [coolant temperature: 50°C (122°F) or less] and hot [coolant temperature: 80°C (176°F) or more].

When engine is cold

Vacuum	Engine status	Normal condition
Try applying vacuum	Idling	Vacuum leaks from the thermo valve

When engine is hot

Vacuum	Engine status	Normal condition
40 mmHg (1.57 in.Hg)	Idling	Vacuum is maintained
150 mmHg (5.91 in.Hg)	Idling → Somewhat unstable	Vacuum is maintained

3. CHECKING OF EGR VALVE (Vehicles for Europe)

(1) Remove the EGR valve and inspect for sticking, carbon deposits, etc. If found, clean with a suitable solvent so that the valve seats correctly.

17-48 EMISSION CONTROL – Service Adjustment Procedures (4G64, G64B engines)

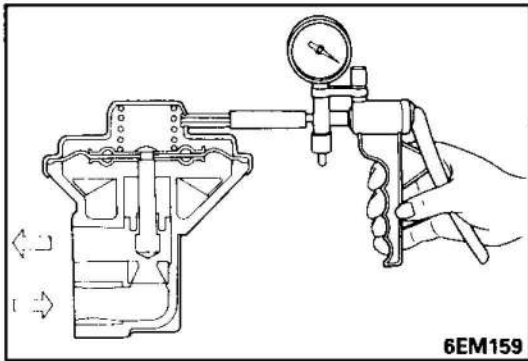

6EM159

- (2) Connect a hand vacuum pump to the EGR valve.
- (3) Apply a vacuum of 500 mmHg (19.7 in.Hg) and make sure that airtightness is maintained.
- (4) Check whether or not air is blown out of the EGR air passage.

Vacuum	Nominal condition
40 mmHg (1.57 in.Hg) or less	Air is not blown out
150 mmHg (5.91 in.Hg) or more	Air is blown out

Caution

When mounting the EGR valve, use a new gasket and tighten to a torque of 19–28 Nm (1.9–2.8 kgm, 14–20 ft.lbs.).

4. CHECKING OF THERMO VALVE (Vehicles for Europe)

Caution

1. Do not apply spanners, etc., to the plastic parts of the thermo valve.
2. When installing, coat threads with a sealant (3M NUT Locking Part No. 4171 or equivalent) and tighten to a torque of 20–40 Nm (2–4 kgm, 15–29 ft.lbs.).
3. When disconnecting the vacuum hose, always make a mark so that the hose can be reconnected at original position.

- (1) Disconnect the vacuum hose (white stripes, green stripes) and connect a hand vacuum pump to the thermo valve.
- (2) Apply vacuum to check the thermo valve.

Engine coolant temperature	Normal condition
50°C (122°F) or less	Vacuum leaks
80°C (176°F) or more	Vacuum is maintained

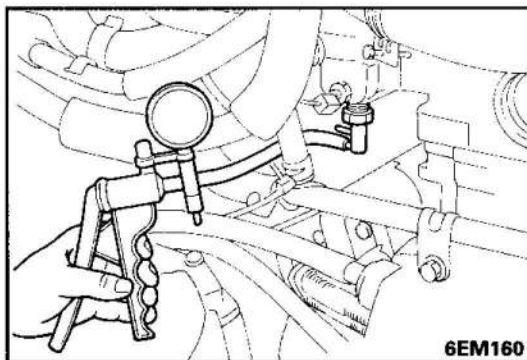

6EM160

5. CHECKING OF EGR VALVE CONTROL VACUUM

Refer to GROUP 13—Service Adjustment Procedures (MPI).

SERVICE ADJUSTMENT PROCEDURES (4G63, 4G64 engines) – Vehicles with MPI built from June 1994

E17FE-2

EMISSION CONTROL DEVICE REFERENCE TABLE

Related parts	Emission control system	Crankcase emission control system	Evaporative emission control system	Air fuel ratio control system	Three catalyst converter	Exhaust gas recirculation (EGR) system*	Reference page for each part inspection
PCV valve		X					17-22-7
Purge control solenoid valve*			X				17-48-6
Canister			X				-
Overflow limiter (2-way valve)			X				Fuel (Group 13)
MPI system component			X	X			Fuel (Group 13)
Three catalyst converter					X		-
EGR valve*						X	17-48-9
EGR control solenoid valve*						X	17-48-9

NOTE

* : Vehicles with 4G63 engine.

17-48-2 EMISSION CONTROL – Service Adjustment Procedures (4G63, 4G64 engines)

VACUUM HOSE PIPING DIAGRAM

<4G63 engine>

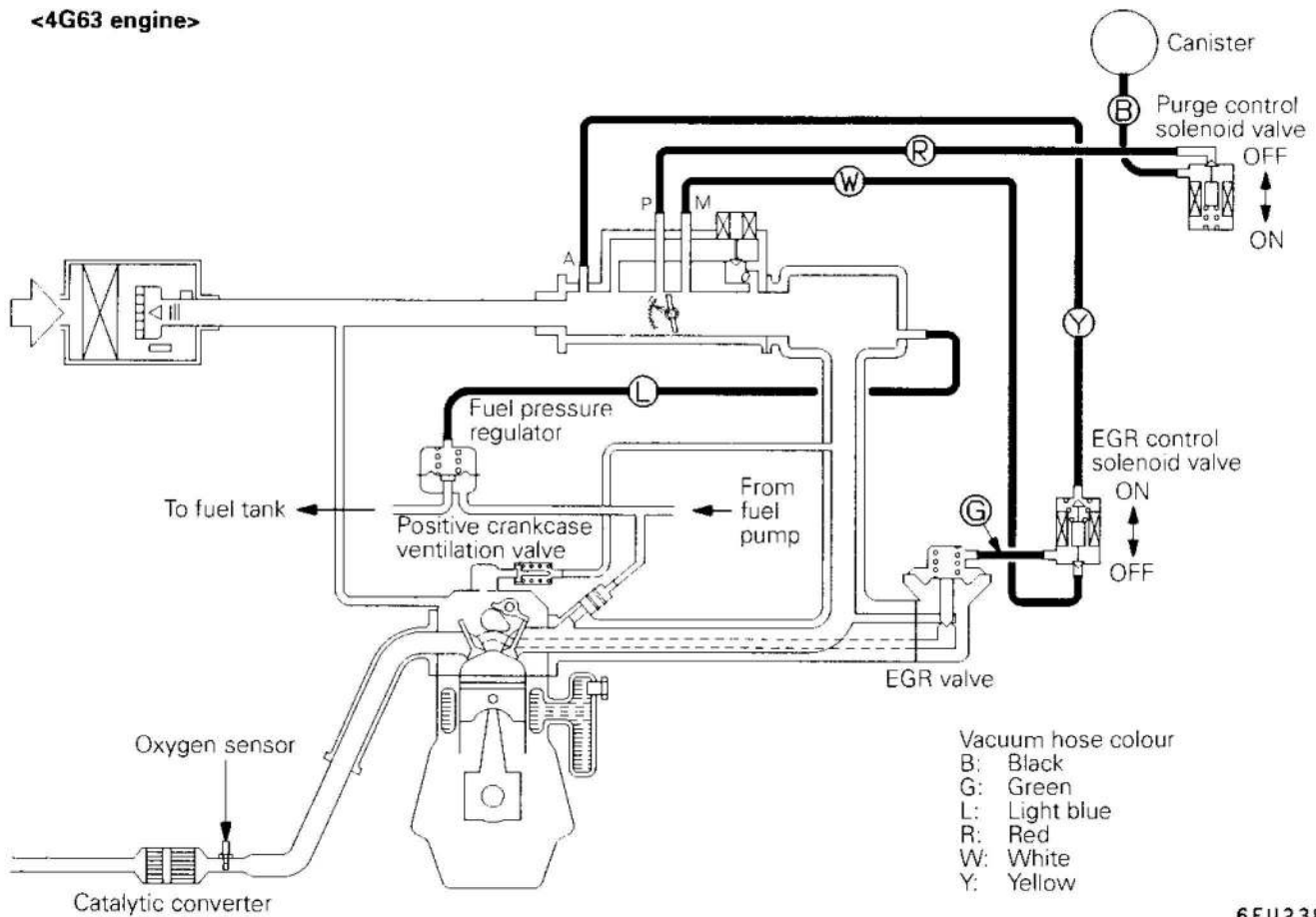

6FU2387

<4G64 engine>

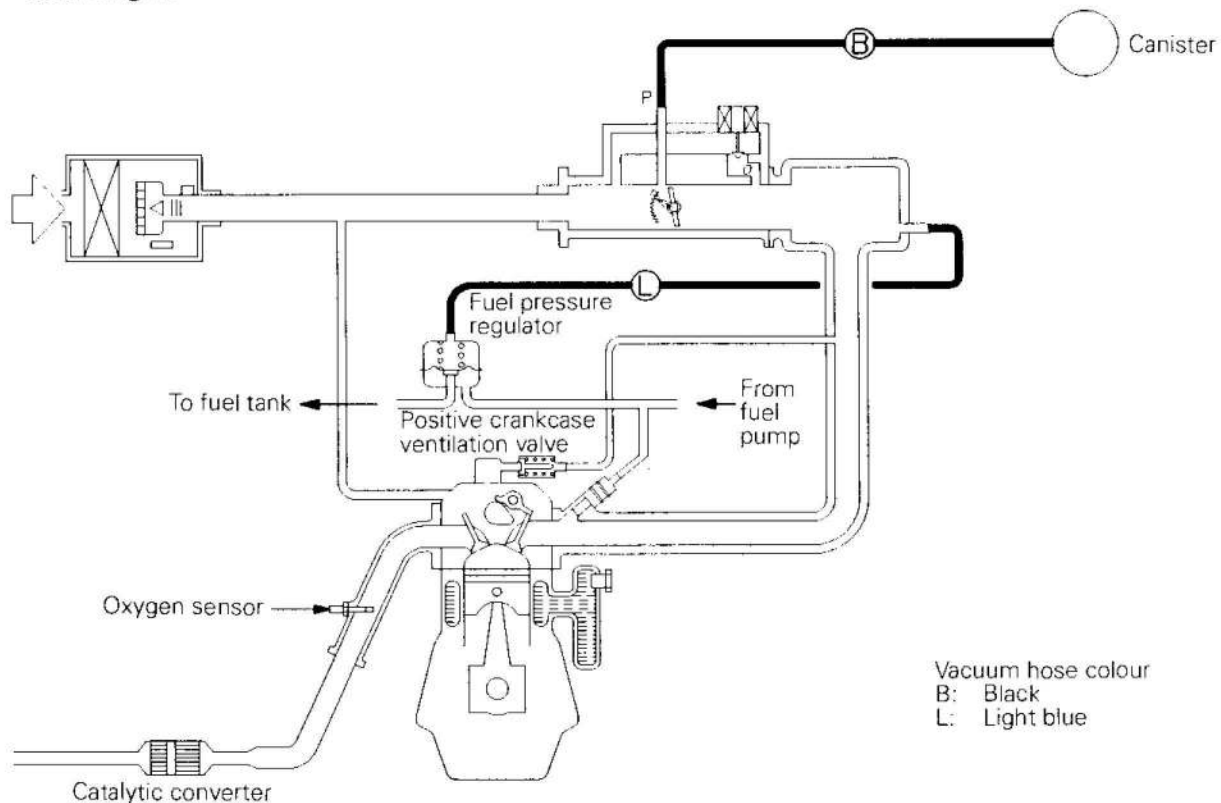

6FU2388

VACUUM HOSE LAYOUT

<4G63 engine>

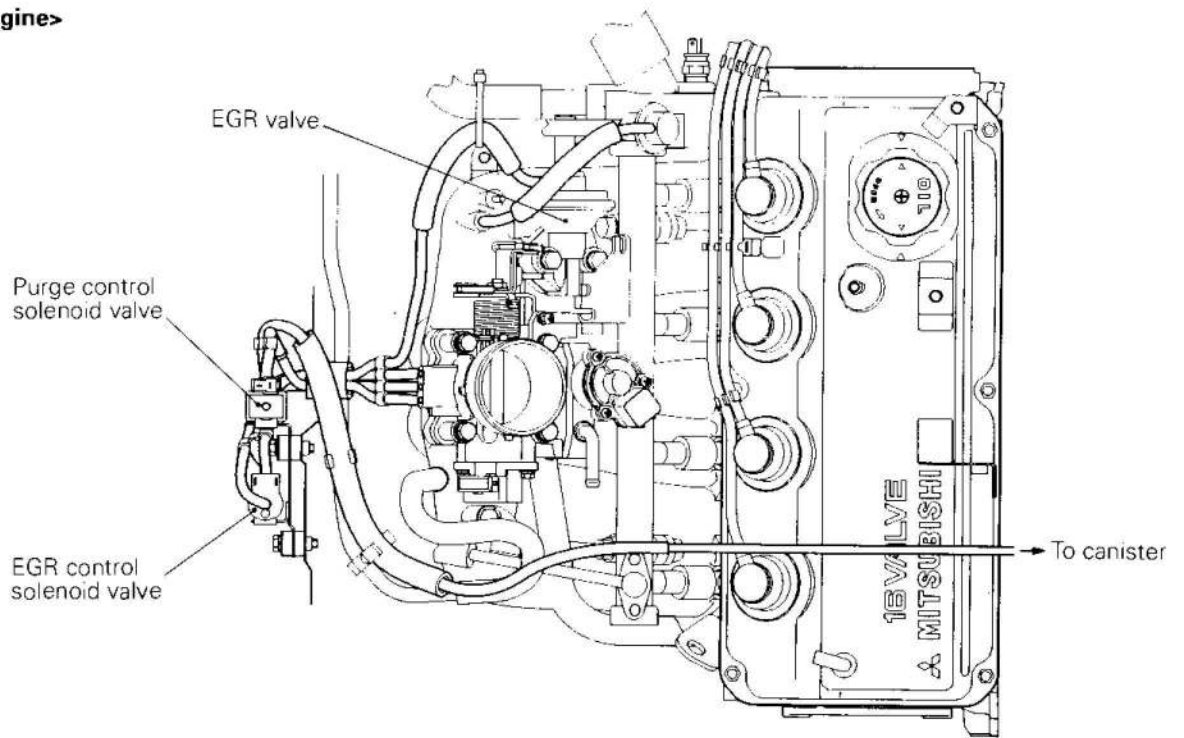

6FU2389

<4G64 engine>

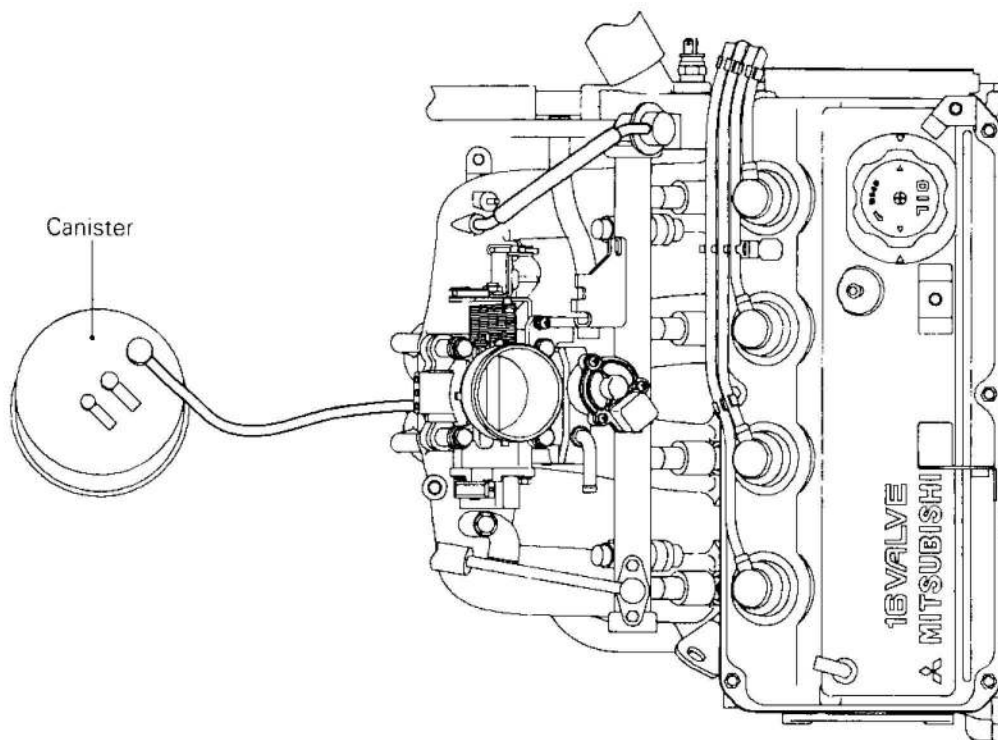

6FU2390

COMPONENT LAYOUT

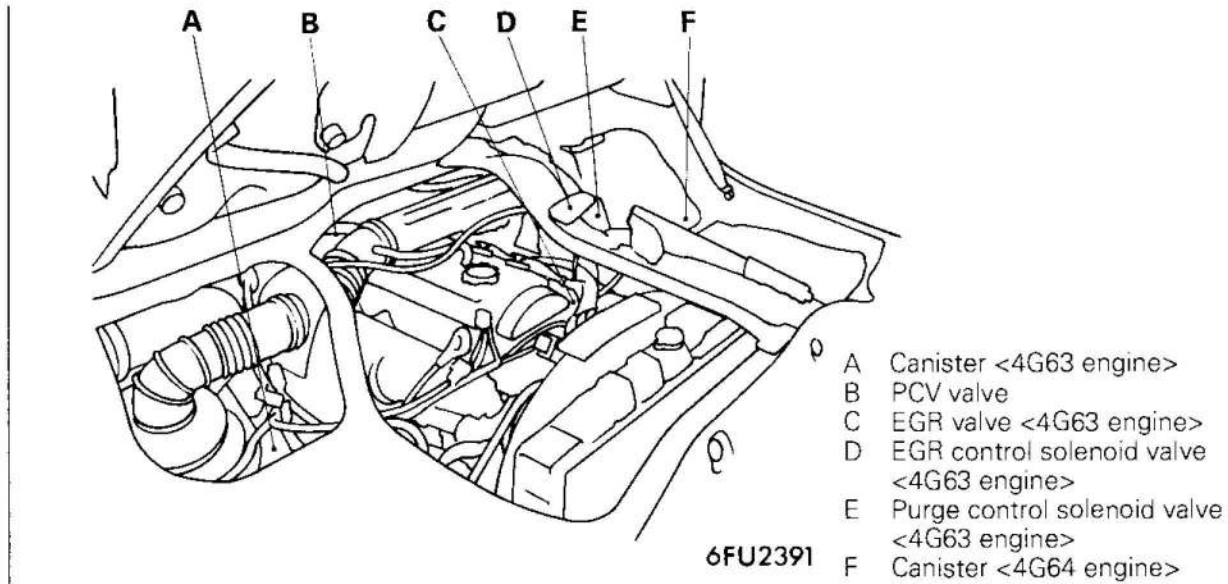

A Canister <4G63 engine>

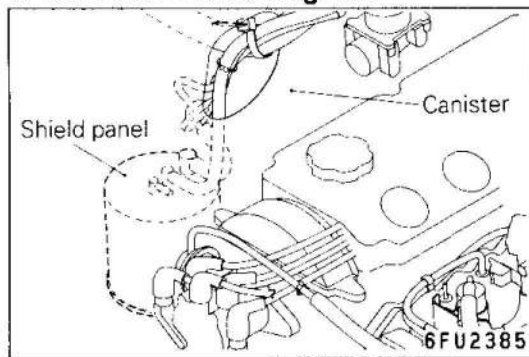

B PCV valve

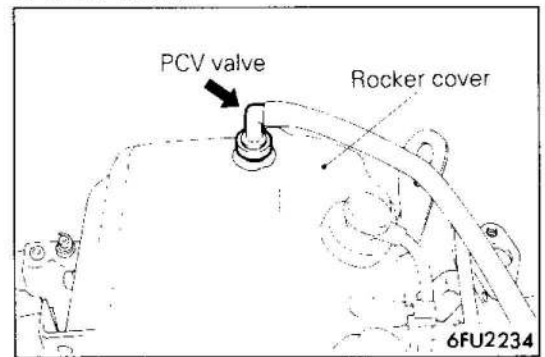

C EGR valve <4G63 engine>

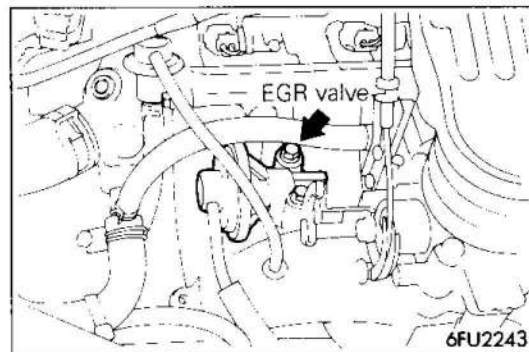

D EGR control solenoid valve <4G63 engine>

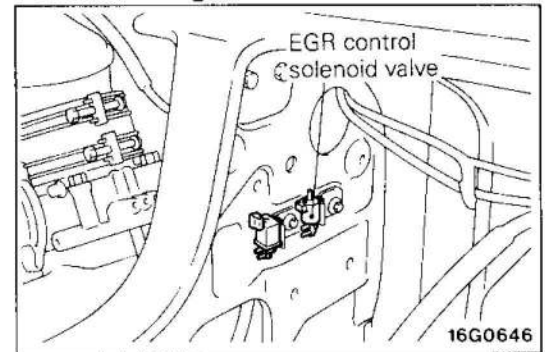

E Purge control solenoid valve <4G63 engine>

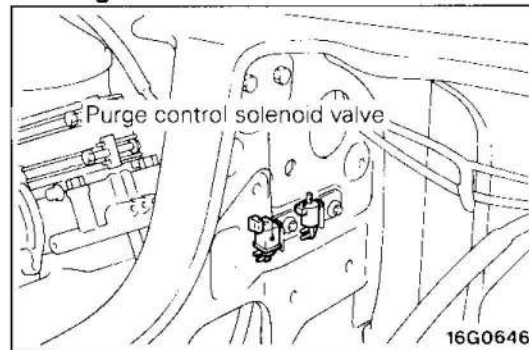

F Canister <4G64 engine>

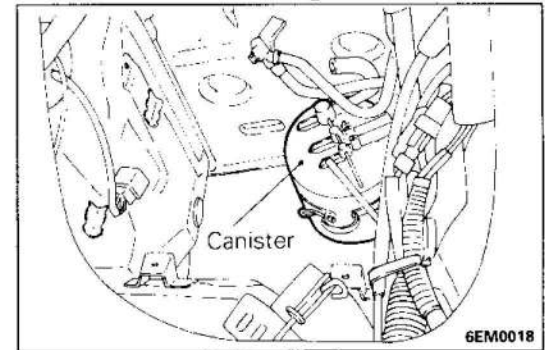

CAUTIONS ON INSPECTION

Refer to P.17-28.

CRANKCASE EMISSION CONTROL SYSTEM

Refer to P.17-22-7.

EVAPORATIVE EMISSION CONTROL SYSTEM

1. CHECKING OF PURGE CONTROL SYSTEM <4G63 engine>

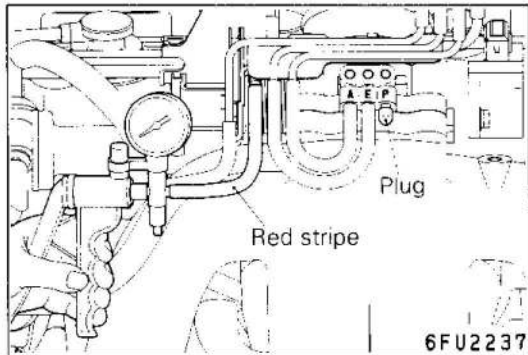
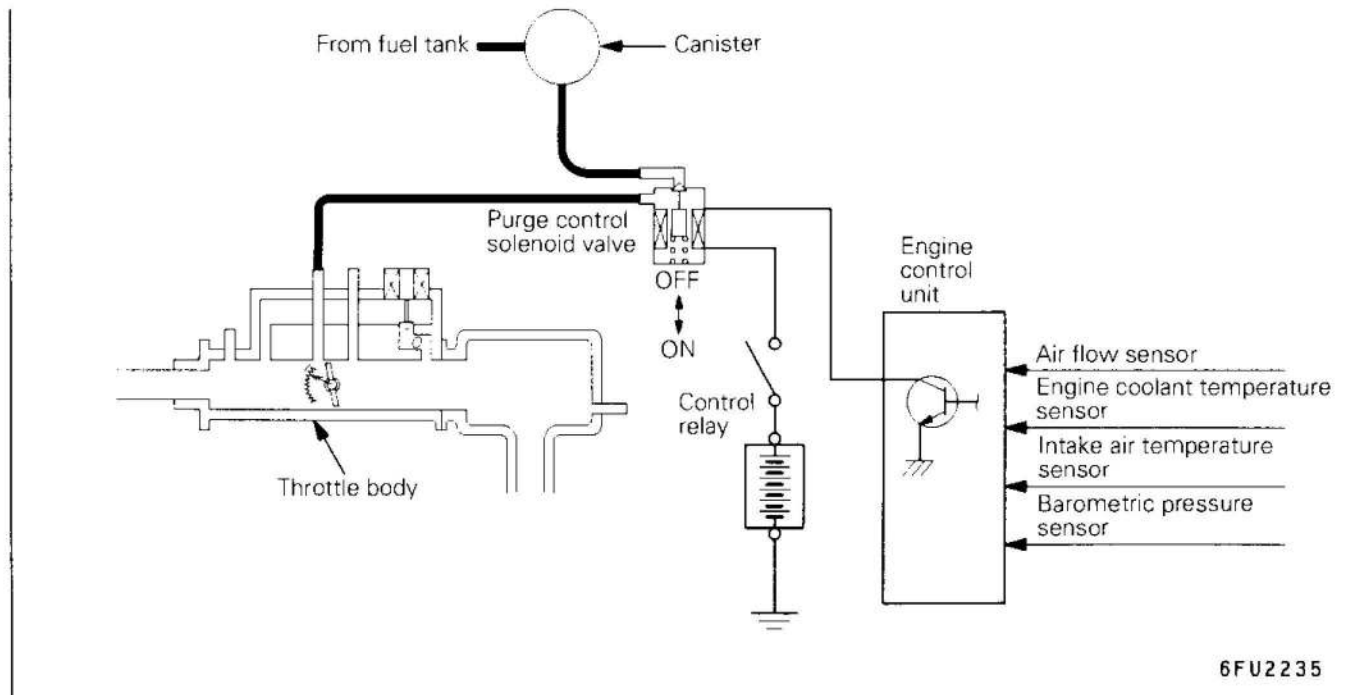

- (1) Disconnect the vacuum hose (red stripe) from the throttle body, and connect it to a hand vacuum pump.
- (2) Plug the nipple from which the vacuum hose was disconnected.
- (3) When the engine is cold and hot, apply a vacuum while the engine is idling, and check the condition of the engine and the vacuum.

When engine is cold
[Engine coolant temperature: 40°C (104°F) or less]

Vacuum	Engine status	Normal condition
400 mmHg (16 in.Hg)	3,000 r/min.	Vacuum is maintained

When engine is hot
[Engine coolant temperature: 80°C (176°F) or higher]

Vacuum	Engine status	Normal condition
400 mmHg (16 in.Hg)	Idling	Vacuum is maintained
	3,000 r/min.	Vacuum will leak for approximately 3 minutes after the engine is started. After 3 minutes have elapsed, the vacuum will be maintained momentarily, after which it will again leak.*

NOTE

* The vacuum will leak continuously if the atmospheric pressure is approximately 580 mmHg (23 in.Hg) or less, or the temperature of the intake air is approximately 50°C (122°F) or higher.

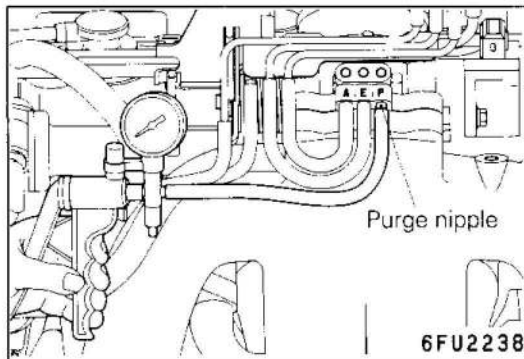

2. CHECKING OF PURGE CONTROL VACUUM
<4G63 engine>

- (1) Disconnect the vacuum hose (red stripe) from the throttle body purge vacuum nipple and connect a hand vacuum pump to the nipple.

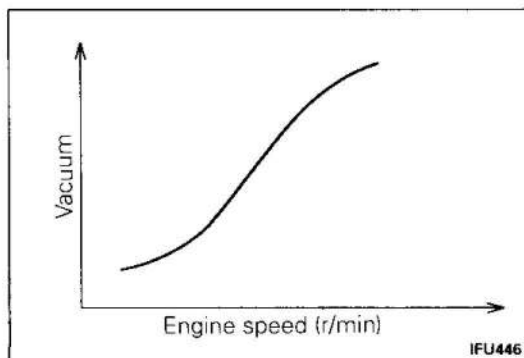

- (2) Start the engine and check to see that, after raising the engine speed by racing the engine, purge vacuum raises proportionately with the rise in engine speed.

NOTE

If there is a problem with the change in vacuum, it is possible that the throttle body purge port may be clogged and require cleaning.

3. CHECKING OF PURGE CONTROL SOLENOID VALVE
<4G63 engine>

NOTE

When disconnecting the vacuum hose, always make a mark so that it can be reconnected at original position.

- (1) Disconnect the vacuum hose (black stripe, red stripe) from the solenoid valve.
- (2) Disconnect the harness connector.

EMISSION CONTROL – Service Adjustment Procedures (4G63, 4G64 engines) 17-48-7

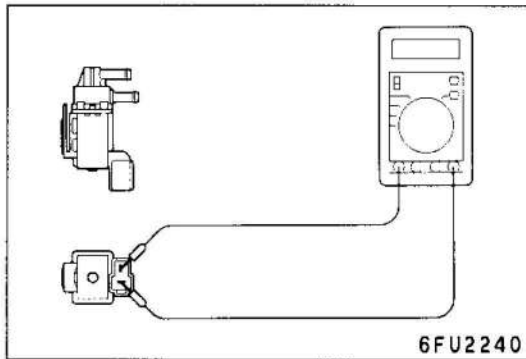
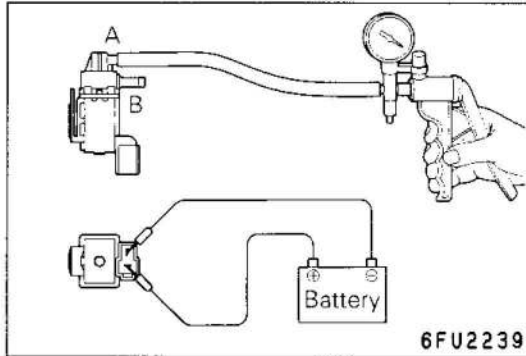

- (3) Connect a hand vacuum pump to nipple (A) of the solenoid valve (refer to the illustration at left).
- (4) Check airtightness by applying a vacuum with voltage applied directly from the battery to the purge control solenoid valve and without applying voltage.

Battery voltage	Normal condition
Applied	Vacuum leaks
Not applied	Vacuum maintained

- (5) Measure the resistance between the terminals of the solenoid valve.

Standard value: 36–44 Ω [at 20°C (68°F)]

4. CHECKING OF AIR FLOW SENSOR <4G63 engine>

Refer to GROUP 13 FUEL – Service Adjustment Procedures (MPI).

5. CHECKING OF COOLANT TEMPERATURE SENSOR <4G63 engine>

Refer to GROUP 13 FUEL – Service Adjustment Procedures (MPI).

6. CHECKING OF INTAKE AIR TEMPERATURE SENSOR <4G63 engine>

Refer to GROUP 13 FUEL – Service Adjustment Procedures (MPI).

7. CHECKING OF 2-WAY VALVE

Refer to GROUP 13 FUEL – Fuel Tank.

8. CHECKING OF CANISTER

Refer to GROUP 13 FUEL – Fuel Line.

**EXHAUST EMISSION CONTROL SYSTEM
<4G63 engine>**

1. CHECKING OF AIR FUEL RATIO CONTROL SYSTEM

Refer to GROUP 13 – Service Adjustment Procedures (MPI).

2. CHECKING OF EXHAUST GAS RECIRCULATION (EGR) SYSTEM <4G63 engine>

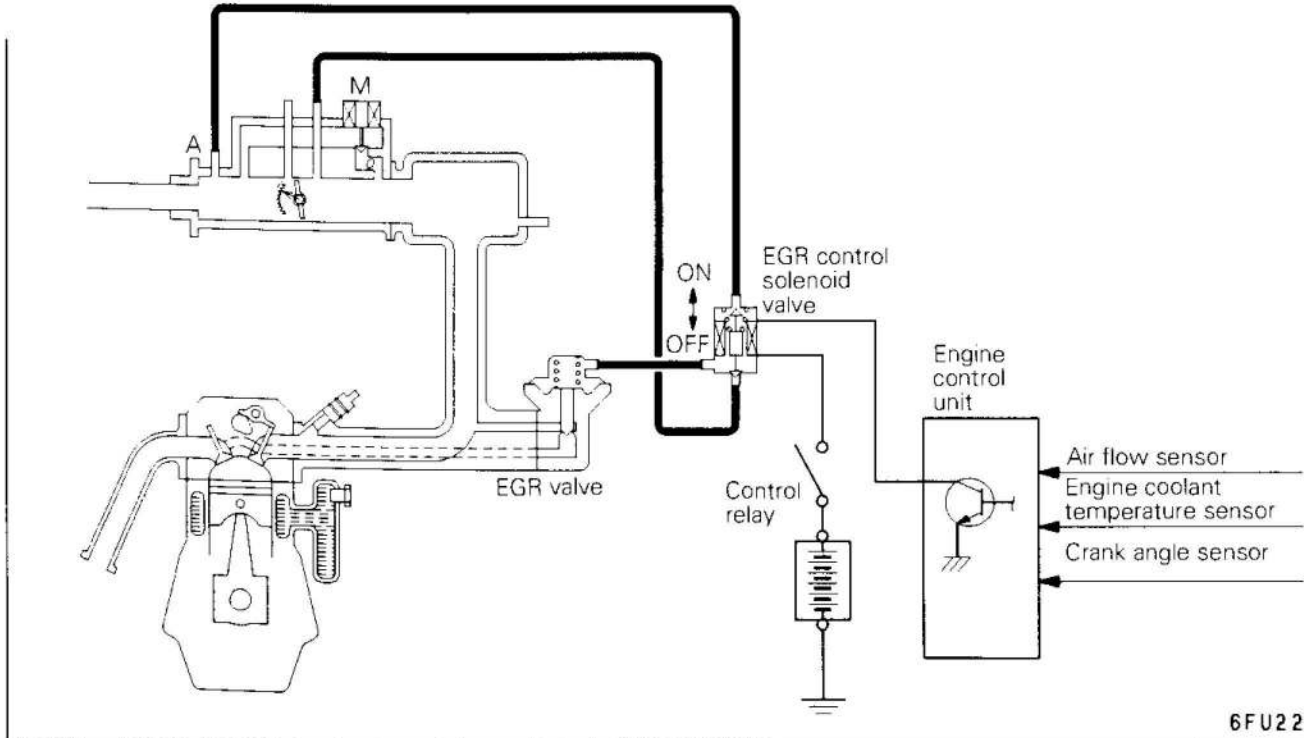

6FU2241

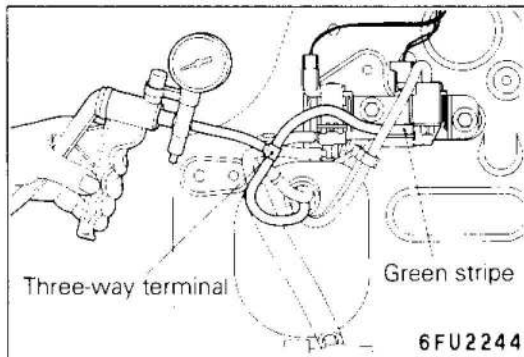

6FU2244

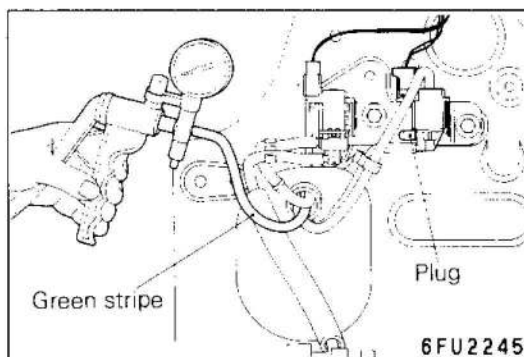

6FU2245

- (1) Disconnect the vacuum hose (green stripe) from the EGR control solenoid valve, and then connect a hand vacuum pump via the three-way terminal.
- (2) Regarding the engine in cold and hot conditions, check the condition of vacuum when a rapid racing has been performed by opening the throttle valve quickly.

When engine is cold

[Engine coolant temperature: 20°C (68°F) or less]

Throttle valve	Normal vacuum condition
Open quickly	No vacuum will generate (remained as barometric pressure).

When engine is hot

[Engine coolant temperature: 80°C (176°F) or higher]

Throttle valve	Normal vacuum condition
Open quickly	It will momentarily rise over 100 mmHg (3.9 in.Hg)

- (3) Disconnect the three-way terminal.
- (4) Connect the hand vacuum pump to the vacuum hose (green stripe).
- (5) Check whether the engine stalls or the idling is unstable when a vacuum of 200 mmHg (27 in.Hg) or higher is applied during idling.

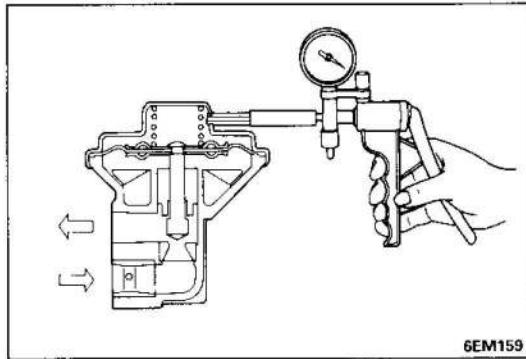

3. CHECKING OF EGR VALVE <4G63 engine>

- (1) Remove the EGR valve and inspect for sticking, carbon deposits, etc. If found, clean with a suitable solvent so that the valve seats correctly.
- (2) Connect a hand vacuum pump to the EGR valve.
- (3) Apply a vacuum of 500 mmHg (19.7 in.Hg) and make sure that airtightness is maintained. Check whether or not air is blown out of the EGR air passage.

Vacuum	Normal condition
40 mmHg (1.57 in.Hg) or less	Air is not blown out
200 mmHg (7.87 in.Hg) or more	Air is blown out

Caution

When mounting the EGR valve, use a new gasket and tighten to a torque of 17–26 Nm (1.7–2.6 kgm, 12–19 ft.lbs.)

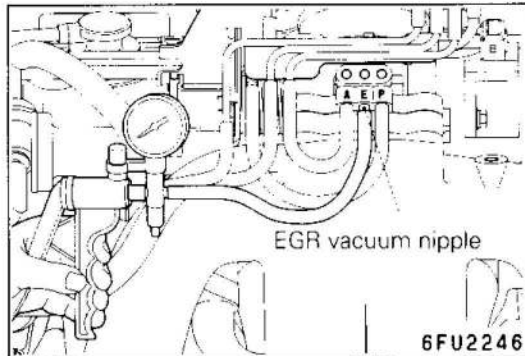

4. CHECKING OF EGR CONTROL VACUUM <4G63 engine>

- (1) Disconnect the vacuum hose (white stripe) from the throttle body EGR vacuum nipple and connect a hand vacuum pump to the nipple.

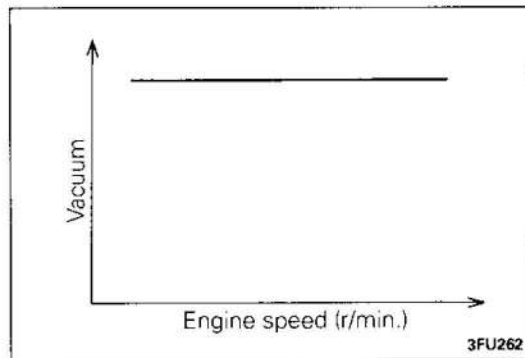

- (2) Start the engine and check to see that, after raising the engine speed by racing the engine, vacuum remains fairly constant.

NOTE

If there is no vacuum created, it is possible that the throttle body EGR port may be clogged and require cleaning.

5. CHECKING OF EGR CONTROL SOLENOID VALVE <4G63 engine>

NOTE

When disconnecting the vacuum hose, always make a mark so that it can be reconnected at original position.

- (1) Disconnect the vacuum hose (yellow stripe, white stripe, green stripe) from the solenoid valve.
- (2) Disconnect the harness connector.

17-48-10 EMISSION CONTROL – Service Adjustment Procedures (4G63, 4G64 engines)

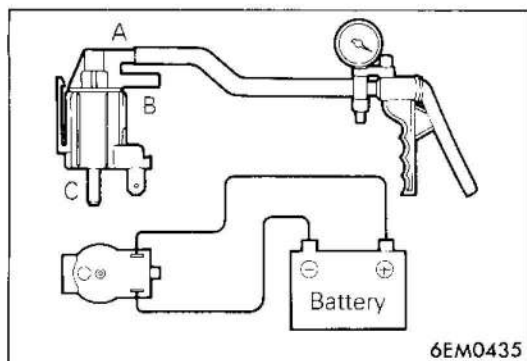

- (3) Connect a hand vacuum pump to the nipple to which the white-striped vacuum hose was connected.
- (4) Check airtightness by applying a vacuum with voltage applied directly from the battery to the EGR control solenoid valve and without applying voltage.

Battery voltage	B nipple condition	Normal condition
Not applied	Open	Vacuum maintained
Applied	Open	Vacuum leaks
	Closed	Vacuum maintained

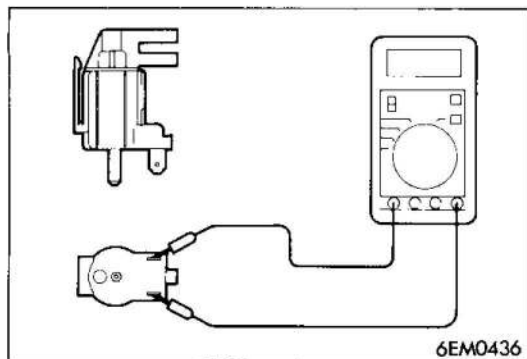

- (5) Measure the resistance between the terminals of the solenoid valve.

Standard value: 36–44Ω [at 20°C (68°F)]

SERVICE ADJUSTMENT PROCEDURES (4D56 engine)**EXHAUST GAS RECIRCULATION (EGR) SYSTEM - VEHICLES WITH TURBOCHARGER FOR SWITZERLAND BUILT FROM NOVEMBER, 1990**

E17FGAE

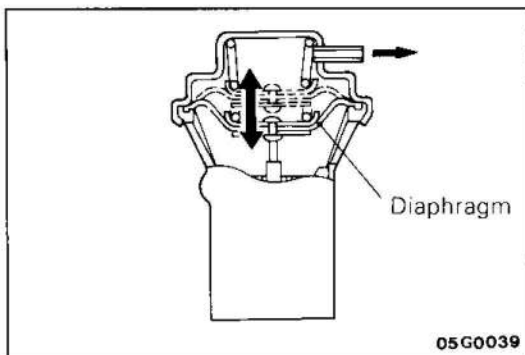
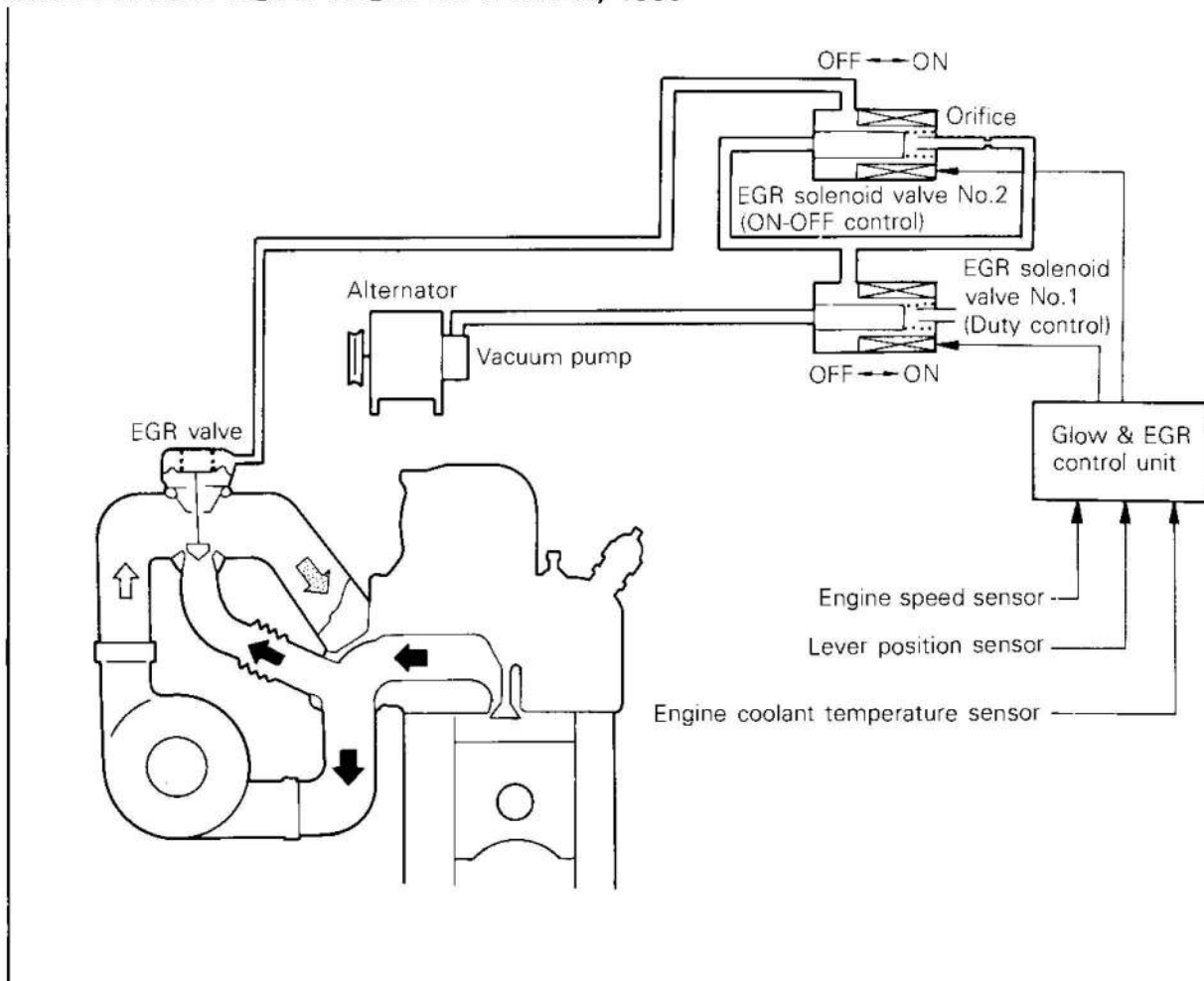
**FUNCTION INSPECTION**

- (1) Start the engine and let it warm up until the engine coolant temperature is 65°C (149°F) or above.
- (2) When the engine is raced by suddenly depressing the accelerator pedal, check to be sure that the diaphragm of the EGR valve lifts.

EGR SOLENOID VALVE NO.1/NO.2 OPERATION INSPECTION

- (1) Remove the EGR solenoid valve No.1/No.2 connectors and vacuum hoses.
- (2) Attach a vacuum pump to each nipple of the EGR solenoid valve No.1/No.2 and apply a vacuum. Check that the valves are airtight both when voltage is applied to each terminal of the EGR solenoid valves and when it is not applied.

17-48-12 EMISSION CONTROL – Service Adjustment Procedures (4D56 engine)

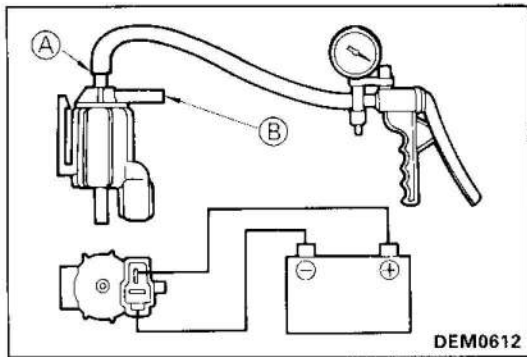

EGR SOLENOID VALVE No. 1

Battery voltage	Normal condition
When current is flowing	Vacuum leaks (Vacuum is maintained when nipple B is covered)
When current is not flowing	Vacuum is maintained

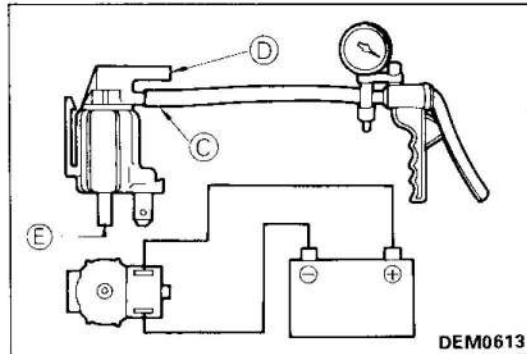

EGR SOLENOID VALVE No. 2

Battery voltage	Normal condition
When current is flowing	Vacuum leaks (Vacuum is maintained when nipple D is covered)
When current is not flowing	Vacuum leaks (Vacuum is maintained when nipple E is covered)

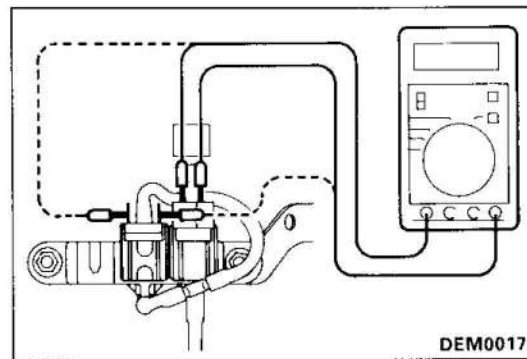

EGR SOLENOID VALVE NO.1/NO.2 RESISTANCE INSPECTION

Measure the coil resistance of the EGR No. 1 and No. 2 solenoid valves with a circuit tester.

Standard value [At 20°C (68°F)]: 36-44Ω

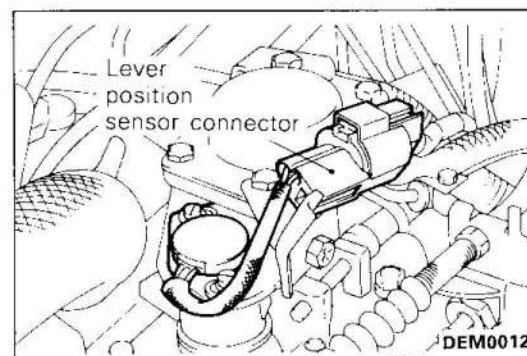

LEVER POSITION SENSOR (LPS) INSPECTION

- (1) Loosen the accelerator cable tension sufficiently.
- (2) Connect the special tool (MD998478) to the lever position sensor connector as shown in the illustration.
- (3) Connect a digital-type voltmeter between the red clip (output) and blue clip (earth) of the connected special tool.

- (4) Turn the ignition switch to ON. (Do not start the engine.)
- (5) Measure the output voltage of the lever position sensor.

Standard value:

Lever condition	Voltage V
Idle position	0.3 - 1.5
Fully open	3.7 - 4.9

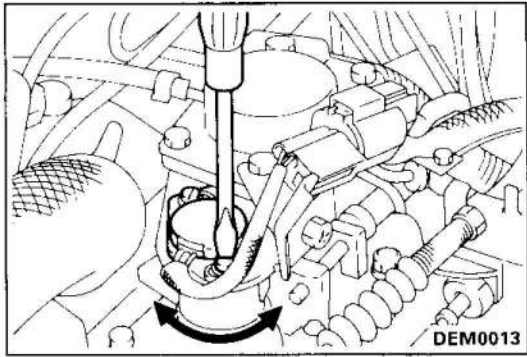

- (6) If the voltage is outside the standard value, adjust by loosening the LPS mounting screw and turning the LPS body. After adjusting, securely tighten the screw.

NOTE

The output voltage will increase if the LPS body is turned in an anti-clockwise direction.

- (7) Turn the ignition switch to "OFF".
- (8) Adjust the accelerator cable play.

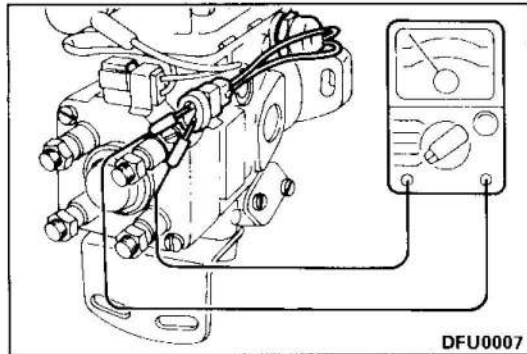

ENGINE SPEED SENSOR INSPECTION

- (1) Disconnect the engine speed sensor connectors.
- (2) Measure the resistance between the engine speed sensor terminals.

Standard value: 1.3 - 1.9 kΩ

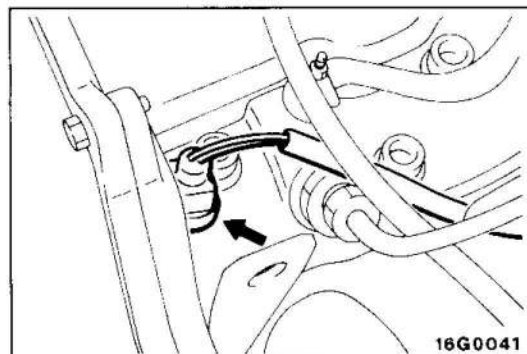

ENGINE COOLANT TEMPERATURE SENSOR INSPECTION

- (1) Remove the engine coolant temperature sensor.

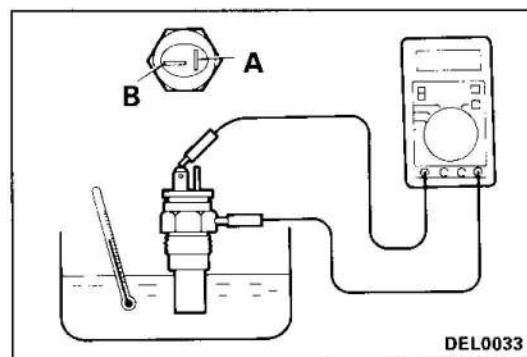

- (2) While the sensor section of the engine coolant temperature sensor is submerged, measure the resistance between (B) terminal and the body.

Temperature [°C (°F)]	Resistance value (k Ω)
-20 (-4)	24.8±2.5
0 (32)	8.6
20 (68)	3.25±0.33
40 (104)	1.5
80 (176)	0.3

- (3) After applying specified sealant to the thread, tighten to the specified torque.

Specified sealant: 3M Nut Locking Part No. 4171 or equivalent

Tightening torque: 30 Nm (3 kgm, 22 ft.lbs.)

GLOW & EGR CONTROL UNIT – VEHICLES WITH TURBOCHARGER FOR SWITZERLAND BUILT FROM NOVEMBER, 1990

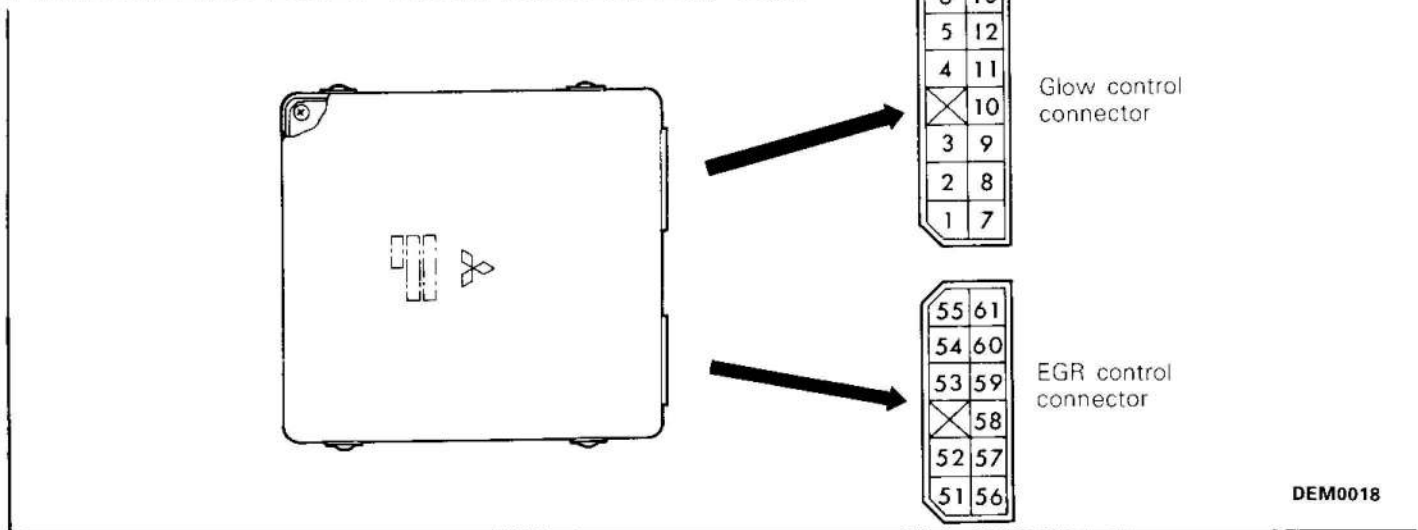

DEM0018

Terminal voltage measurement

NOTE

- (1) Inspect with the glow & EGR control unit connectors connected.
- (2) When measuring the voltage, the earth will be the glow & EGR unit terminal no. 10.

Terminal Voltage Reference Table

Glow & EGR control unit inspection terminal	Inspection item	Inspection conditions	Standard value
52	EGR solenoid valve No.1	Ignition switch: OFF → ON	11 – 13V
		While engine is idling after having warmed up, suddenly race the engine.	Momentarily increases
53	Lever position sensor	Ignition switch: OFF → ON	0.3 – 1.5V
		Throttle lever idle position Throttle lever fully open position	3.7 – 4.9
55	Sensor power supply <M/T only>	Ignition switch: OFF → ON	4.5 – 5.5V
58	EGR solenoid valve No.2	Ignition switch: OFF → ON	11 – 13V
		While engine is idling after having warmed up, suddenly race the engine.	Momentarily decreases

Glow & EGR control unit harness-side connector (11P) seen from the terminal side

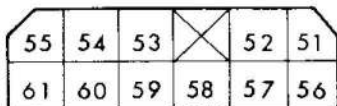

DEM0015

Harness continuity inspection

- (1) Disconnect the glow & EGR control unit connector.
- (2) Check to be sure that there is continuity (1.3 – 1.9 kΩ) between harness-side connector terminals 60 – 61.

GLOW & EGR CONTROL UNIT – Vehicles built from July 1993

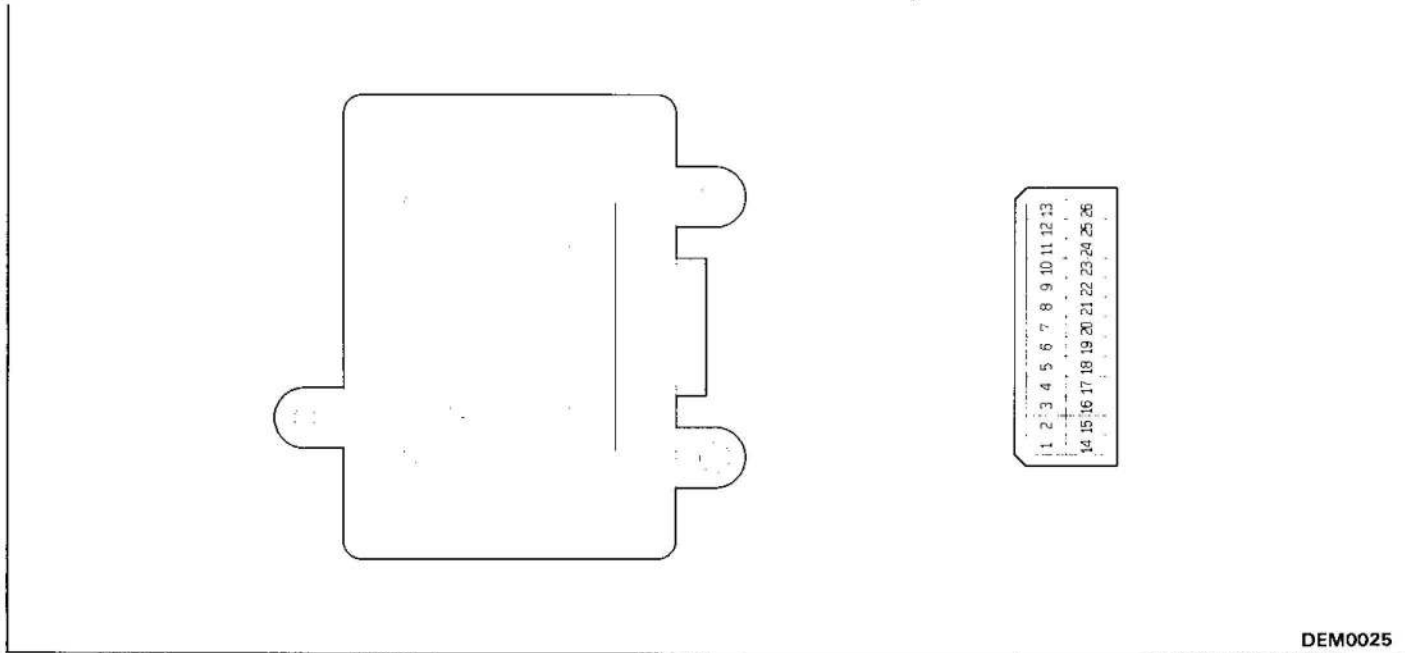

DEM0025

TERMINAL VOLTAGE MEASUREMENT

NOTE

- (1) Inspect with the glow & EGR control unit connectors still connected.
- (2) When measuring the voltage, the earth will be the glow & EGR unit terminal No. 26.

Terminal Voltage Reference Table

Glow & EGR control unit inspection terminal	Inspection item	Inspection conditions	Standard value
3	EGR solenoid valve No. 1	Ignition switch: OFF → ON	11 – 13V
		While engine is idling after having warmed up, suddenly race the engine.	Momentarily increases
6	Lever position sensor	Ignition switch: OFF → ON	0.3 – 1.5V
		Throttle lever idle position Throttle lever fully open position	3.7 – 4.9V
7	Sensor power supply	Ignition switch: OFF → ON	4.5 – 5.5V
16	EGR solenoid valve No.2	Ignition switch: OFF → ON	11 – 13V
		While engine is idling after having warmed up, suddenly race the engine.	Momentarily decreases

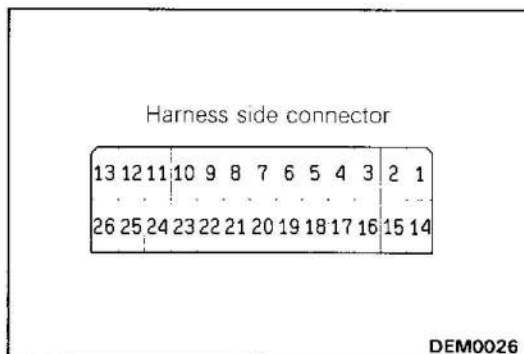

DEM0026

HARNES CONTINUITY INSPECTION

- (1) Disconnect the glow & EGR control unit connector.
- (2) Check to be sure that there is continuity (1.3–1.9 kΩ) between the harness-side connector terminals 11 – 12.

NOTES

CATALYTIC CONVERTER REMOVAL AND INSTALLATION

E17YA--

Type A

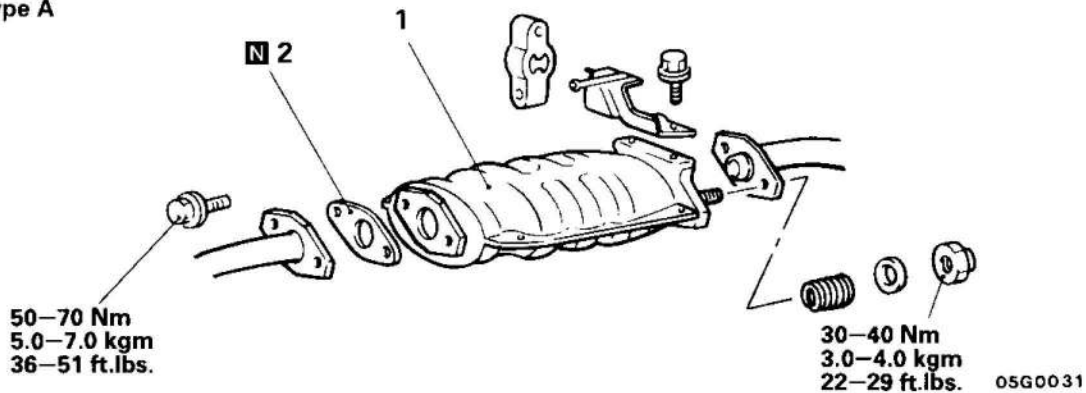

Type B

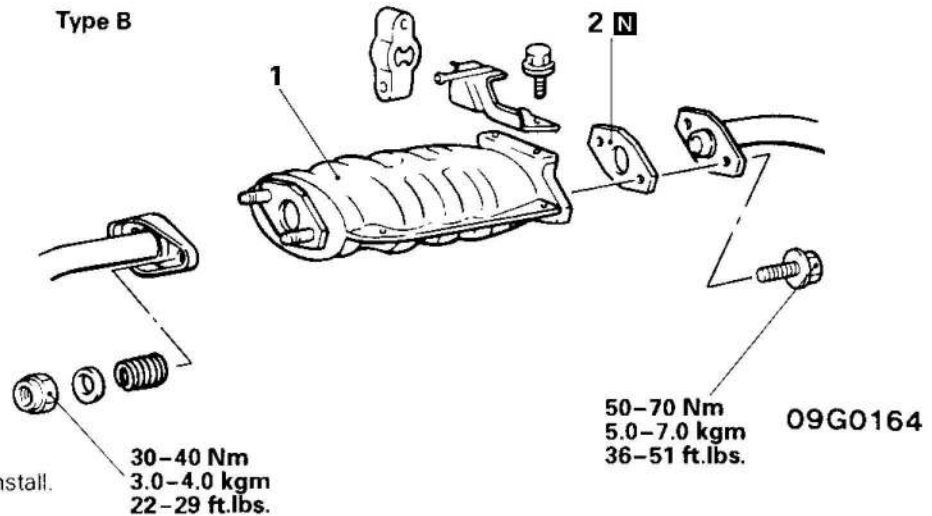

Removal steps

1. Catalytic converter
2. Gasket

NOTE

Reverse the removal procedures to reinstall.

CHECKING OF CATALYTIC CONVERTER

E17YCAA

Inspect for damage, cracking or deterioration. Replace if faulty.

Caution

1. Operation of any type, including idling, should be avoided if engine misfiring occurs. Under this condition the exhaust system will operate at abnormally high temperature, which may cause damage to the catalyst or underbody parts of the vehicle.
2. Alteration or deterioration of ignition or fuel system, or any type of operating condition which results in engine misfiring must be corrected to avoid overheating the catalytic converters.
3. Proper maintenance and tune up according to manufacturer's specifications should be made to correct the conditions as soon as possible.

NOTES